

PHILIPS

Data handbook



Electronic
components
and materials

Components and materials

Book C22

1985

Film capacitors

Elcoma – Philips Electronic Components and Materials Division – embraces a world-wide group of companies operating under the following names:

IBRAPE

PHILIPS

MBLE



Miniwatt

signetics

Mullard

VALVO

Elcoma offers you a technological partnership in developing your systems to the full. A partnership to which we can bring

- world-wide production and marketing
- know-how
- systems approach
- continuity
- broad product line
- fundamental research
- leading technologies
- applications support
- quality

FILM CAPACITORS

	<i>page</i>
Selection guide	2
Metallized polyethylenetherephthalate film capacitors (MKT)	7
Inspection requirements (MKT)	69
Polyethylenetherephthalate film/foil capacitors (KT)	93
Inspection requirements (KT)	107
Metallized polycarbonate film capacitors (MKC)	115
Inspection requirements (MKC)	141
Polystyrene film/foil capacitors (KS)	163
Inspection requirements (KS)	203
Polypropylene film/foil capacitors (KP)	231
Inspection requirements (KP)	265
A.C. and pulse metallized polypropylene film capacitors (KP/MKP and KP/MMKP)	287
Inspection requirements (KP/MKP and KP/MMKP)	311
Interference suppression capacitors (MKT-P)	321
Inspection requirements (MKT-P)	331

DATA HANDBOOK SYSTEM

Our Data Handbook System comprises more than 60 books with specifications on electronic components, subassemblies and materials. It is made up of four series of handbooks:

ELECTRON TUBES	BLUE
SEMICONDUCTORS	RED
INTEGRATED CIRCUITS	PURPLE
COMPONENTS AND MATERIALS	GREEN

The contents of each series are listed on pages iv to viii.

The data handbooks contain all pertinent data available at the time of publication, and each is revised and reissued periodically.

When ratings or specifications differ from those published in the preceding edition they are indicated with arrows in the page margin. Where application information is given it is advisory and does not form part of the product specification.

Condensed data on the preferred products of Philips Electronic Components and Materials Division is given in our Preferred Type Range catalogue (issued annually).

Information on current Data Handbooks and on how to obtain a subscription for future issues is available from any of the Organizations listed on the back cover.

Product specialists are at your service and enquiries will be answered promptly.

ELECTRON TUBES (BLUE SERIES)

The blue series of data handbooks comprises:

- T1** Tubes for r.f. heating
- T2a** Transmitting tubes for communications, glass types
- T2b** Transmitting tubes for communications, ceramic types
- T3** Klystrons, travelling-wave tubes, microwave diodes
- ET3** Special Quality tubes, miscellaneous devices (will not be reprinted)
- T4** Magnetrons for microwave heating
- T5** Cathode-ray tubes
Instrument tubes, monitor and display tubes, C.R. tubes for special applications
- T6** Geiger-Müller tubes
- T7** Gas-filled tubes
Segment indicator tubes, indicator tubes, dry reed contact units, thyratrons, industrial rectifying tubes, ignitrons, high-voltage rectifying tubes, associated accessories
- T8** Picture tubes and components
Colour TV picture tubes, black and white TV picture tubes, colour monitor tubes for data graphic display, monochrome monitor tubes for data graphic display, components for colour television, components for black and white television and monochrome data graphic display
- T9** Photo and electron multipliers
Photomultiplier tubes, phototubes, single channel electron multipliers, channel electron multiplier plates
- T10** Camera tubes and accessories
- T11** Microwave semiconductors and components
- T12** Vidicons and Newvicons
- T13** Image intensifiers
- T14** Infrared detectors
- T15** Dry reed switches
- T16** Monochrome tubes and deflection units
Black and white TV picture tubes, monochrome data graphic display tubes, deflection units

} Data collations on these subjects are available now.
Data Handbooks will be published in 1985.

SEMICONDUCTORS (RED SERIES)

The red series of data handbooks comprises:

- S1 Diodes**
Small-signal germanium diodes, small-signal silicon diodes, voltage regulator diodes (< 1,5 W), voltage reference diodes, tuner diodes, rectifier diodes
- S2a Power diodes**
- S2b Thyristors and triacs**
- S3 Small-signal transistors**
- S4a Low-frequency power transistors and hybrid modules**
- S4b High-voltage and switching power transistors**
- S5 Field-effect transistors**
- S6 R.F. power transistors and modules**
- S7 Surface mounted semiconductors**
- S8 Devices for optoelectronics**
Photosensitive diodes and transistors, light-emitting diodes, displays, photocouplers, infrared sensitive devices, photoconductive devices.
- S9 Power MOS transistors**
- S10 Wideband transistors and wideband hybrid IC modules**
- S11 Microwave semiconductors** (to be published in this series in 1985)
At present available in Handbook T11
- S12 Surface acoustic wave devices**

INTEGRATED CIRCUITS (PURPLE SERIES)

The purple series of data handbooks comprises:

EXISTING SERIES

Superseded by:

IC1	Bipolar ICs for radio and audio equipment	
IC2	Bipolar ICs for video equipment	IC02N
IC3	ICs for digital systems in radio, audio and video equipment	
IC4	Digital integrated circuits CMOS HE4000B family	
IC5	Digital integrated circuits – ECL ECL10 000 (GX family), ECL100 000 (HX family), dedicated designs	IC08N
IC6	Professional analogue integrated circuits	
IC7	Signetics bipolar memories	
IC8	Signetics analogue circuits	IC11N
IC9	Signetics TTL logic	IC09N and IC15N
IC10	Signetics Integrated Fuse Logic (IFL)	IC13N
IC11	Microprocessors, microcomputers and peripheral circuitry	

NEW SERIES

IC01N	Radio, audio and associated systems Bipolar, MOS	
IC02N	Video and associated systems Bipolar, MOS	(published 1985)
IC03N	Integrated circuits for telephony Bipolar, MOS	(published 1985)
IC04N	HE4000B logic family CMOS	
IC05N	HE4000B logic family uncased integrated circuits CMOS	(published 1984)
IC06N	High-speed CMOS; PC54/74HC/HCT/HCU Logic family	(published 1985)
IC07N	PC54/74HC/HCU/HCT uncased integrated circuits HCMOS	
IC08N	10K and 100K logic family ECL	(published 1984)
IC09N	Logic series TTL	(published 1984)
IC10N	Memories MOS, TTL, ECL	
IC11N	Linear LSI	(published 1985)
IC12N	Semi-custom gate arrays & cell libraries ISL, ECL, CMOS	
IC13N	Semi-custom Integrated Fuse Logic	(published 1985)
IC14N	Microprocessors, microcontrollers & peripherals Bipolar, MOS	
IC15N	Logic series FAST TTL	(published 1984)

Note

Books available in the new series are shown with their date of publication.







COMPONENTS AND MATERIALS (GREEN SERIES)

The green series of data handbooks comprises:



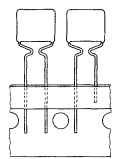

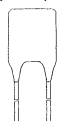
- C1 Programmable controller modules**
PLC modules, PC20 modules
- C2 Television tuners, video modulators, surface acoustic wave filters**
- C3 Loudspeakers**
- C4 Ferroxcube potcores, square cores and cross cores**
- C5 Ferroxcube for power, audio/video and accelerators**
- C6 Synchronous motors and gearboxes**
- C7 Variable capacitors**
- C8 Variable mains transformers**
- C9 Piezoelectric quartz devices**
Quartz crystal units, temperature compensated crystal oscillators, compact integrated oscillators, quartz crystal cuts for temperature measurements
- C10 Connectors**
- C11 Non-linear resistors**
Voltage dependent resistors (VDR), light dependent resistors (LDR), negative temperature coefficient thermistors (NTC), positive temperature coefficient thermistors (PTC)
- C12 Potentiometers, encoders and switches**
- C13 Fixed resistors**
- C14 Electrolytic and solid capacitors**
- C15 Ceramic capacitors**
- C16 Permanent magnet materials**
- C17 Stepping motors and associated electronics**
- C18 D.C. motors**
- C19 Piezoelectric ceramics**
- C20 Wire-wound components for TVs and monitors**
- C21 Assemblies for industrial use**
HNIL FZ/30 series, NORbits 60-, 61-, 90-series, input devices
- C22 Film capacitors**

SELECTION GUIDE

SELECTION GUIDE

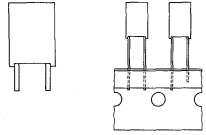
style 2222 ...	type	rated cap. range	rated voltage V	pitch mm	page
METALLIZED POLYETHYLENETEREPHTHALATE FILM CAPACITORS (MKT)					
341	moulded 	0,082 -6,8 μ F 0,039 -2,2 μ F 0,0082-1,0 μ F	100 250 400		9
 344	potted 	0,18 -10 μ F 0,082 -10 μ F 0,039 -2,2 μ F 0,010 -1,0 μ F	63 100 250 400	10, 15, 22,5, 27,5	21
365	epoxy lacquered 	0,047 -0,47 μ F 0,01 -0,10 μ F 0,12 -0,47 μ F 0,039 -0,27 μ F 0,018 -0,047 μ F 0,0039-0,015 μ F	63 100 63 100 250 400	5,08 5,08*	41
366	epoxy lacquered 	0,047 -0,47 μ F 0,01 -0,10 μ F 0,12 -0,47 μ F 0,039 -0,27 μ F 0,018 -0,033 μ F 0,0039-0,015 μ F	63 100 63 100 250 400	5,08 7,62	41
367	epoxy lacquered 	0,047 -0,47 μ F 0,01 -0,10 μ F 0,12 -0,47 μ F 0,039 -0,27 μ F 0,018 -0,033 μ F 0,0039-0,015 μ F	63 100 63 100 250 400	5,08 7,62	41
368	epoxy lacquered 	0,056 -6,8 μ F 0,027 -2,2 μ F 0,001 -1,0 μ F 0,01 -0,47 μ F	100 250 400 630	10,16, 15,24, 22,86, 27,94	41
369	epoxy lacquered 	0,056 -0,22 μ F 0,027 -0,10 μ F 0,001 -0,033 μ F 0,010 -0,022 μ F	100 250 400 630	10,16	41

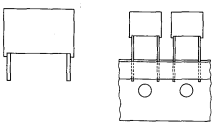
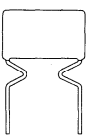
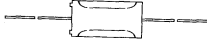

* Original pitch 7,62 mm reduced to 5,08 mm.

style 2222 . . .	type	rated cap. range	rated voltage V	pitch mm	page
 370	potted 	0,039 – 0,68 μF 0,0039 – 0,10 μF	63 100	5,08	21
 371	potted 	0,056 – 1,0 μF 0,018 – 0,47 μF 0,0082 – 0,033 μF 0,0039 – 0,010 μF	63 100 250 400	7,62	21
POLYETHYLENETEREPHTHALATE FILM/FOIL CAPACITORS (KT)					
347	phenolic lacquered 	0,015 – 1,0 μF 0,0082 – 0,68 μF 0,0047 – 0,33 μF 0,001 – 0,15 μF	100 250 400 630	10,16, 15,24, 22,86, 27,94	95
METALLIZED POLYCARBONATE FILM CAPACITORS (MKC)					
341	moulded 	0,082 – 6,8 μF 0,039 – 2,2 μF 0,0082 – 1,0 μF 0,0082 – 0,47 μF 0,0082 – 0,15 μF	100 250 400 630 1000		117
344	potted 	0,082 – 6,8 μF 0,039 – 2,2 μF 0,010 – 1,0 μF 0,010 – 0,47 μF	100 250 400 630	10, 15, 22,5, 27,5	129



FILM CAPACITORS

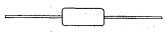
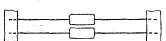

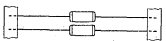
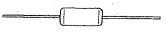

style 2222 . . .	type	rated cap. range	rated voltage V	pitch mm	page
---------------------	------	------------------	-----------------------	-------------	------

POLYSTYRENE FILM/FOIL CAPACITORS (KS)

424	sleeved	2 000– 39 000 pF	63		165
425		1 100– 16 000 pF	160		
426		560– 11 000 pF	250		
427		51– 5 600 pF	630		
428		2 000– 39 000 pF	63		
429		1 100– 16 000 pF	160		193
430		560– 11 000 pF	250		
431		51– 5 600 pF	630		
443	potted	100– 34 000 pF	63	2,54, 5,08, 7,62	179
444	wrapped end-filled	43 000–162 000 pF	63		193
445		18 000– 82 000 pF	160		
446		12 000– 47 000 pF	250		
447		6 200– 24 000 pF	630		

POLYPROPYLENE FILM/FOIL CAPACITORS (KP)

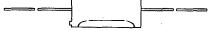
455	sleeved	3 300– 56 000 pF	63		241
456		1 800– 36 000 pF	160		
457		47– 20 000 pF	250		
460	epoxy lacquered	6 800– 62 000 pF	63		253
461		3 600– 39 000 pF	160		
462		47– 22 000 pF	250		
357 5....	potted	0,039–0,82 μ F	250	15, 22,5, 27,5	233
					

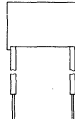
style 2222 . . .	type	rated cap. range	rated voltage V	pitch mm	page
A.C. AND PULSE METALLIZED POLYPROPYLENE FILM CAPACITORS					
(KP/MKP) 357 6 357 7 357 8 357 9	potted 	0,047 -0,33 μ F 0,016 -0,22 μ F 0,0082-0,15 μ F 0,001 -0,013 μ F	630 1000 1500 2000	22,5, 27,5	289
(KP/MMKP) 376	potted 	0,027 -0,27 μ F 0,015 -0,18 μ F 0,0068-0,015 μ F 0,0010-0,010 μ F	630 1000 1500 2000	22,5, 27,5	301
INTERFERENCE SUPPRESSION CAPACITORS (MKT-P)					
330 0	moulded 	0,01 -0,47 μ F	250 V~		323
330 4	potted 	0,01 -1,0 μ F	250 V~	15, 22,5, 27,5	323
330 8	potted; insulated leads 	0,01 -0,1 μ F	250 V~	15	323

METALLIZED POLYETHYLENETHERPHTHALATE FILM CAPACITORS
(MKT)

METALLIZED POLYETHYLENETEREPHTHALATE FILM CAPACITORS

MKT axial moulded type

- Supplied in boxes

QUICK REFERENCE DATA

Rated capacitance range (E12-series)	0,0082 to 6,8 μ F
Tolerance on rated capacitance	$\pm 20\%$, $\pm 10\%$, $\pm 5\%$
Rated voltage U_R (d.c.)	100 V, 250 V, 400 V
Climatic category	55/100/56
Rated temperature	85 $^{\circ}$ C
Tangent of loss angle at 10 kHz	100×10^{-4}
Related specification	IEC 384-2
Performance grade	general purpose

STYLE



Style 2222 341; see Tables 1 to 3.

APPLICATION

In electronic circuits for blocking and coupling, bypass and energy reservoir applications.

DESCRIPTION

The capacitors consist of a low-inductance wound cell of metallized polyethyleneterephthalate (PETP) film. The cell is moulded in yellow flame retardent polypropylene. The axial leads are of solder-coated wire. One end of the capacitor is provided with two stand-off ridges to allow removal of solder flux etc., when cleaning the printed-wiring board.

GENERAL DATA

Dimensions in mm

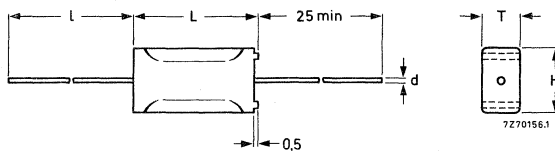

Fig. 1.

Table 1-U_R (d.c.) = 100 V; max. a.c. voltage = 63 V; Fig. 1

rated capacitance μF	T _{max}	H _{max}	L _{max}	d	ℓ min	mass g	catalogue number 2222 341											
							tol. \pm 20%	tol. \pm 10%	tol. \pm 5%									
0,082	5,1	8,8	14,6	0,8	40	1,0	26823	27823	25823									
0,10							26104	27104	25104									
0,12							26124	27124	25124									
0,15							26154	27154	25154									
0,18							26184	27184	25184									
0,22						5,7	9,5	14,6	0,8	40	26224	27224	25224					
0,27											26274	27274	25274					
0,33											6,6	10,4	18,1	0,8	40	26334	27334	25334
0,39																26394	27394	25394
0,47																26474	27474	25474
0,56	7,9	11,5	18,1	0,8	40	26564	27564	25564										
0,68	7,8	11,6	23,5			26684	27684	25684										
0,82	9,2	12,9	23,5			0,8	40	26824	27824	25824								
1,0								26105	27105	25105								
1,2								26125	27125	25125								
1,5	10,8	14,5	23,5	0,8	40	26155	27155	25155										
1,8						26185	27185	25185										
2,2	10,7	14,6	31	1	50	26225	27225	25225										
2,7						26275	27275	25275										
3,3						26335	27335	25335										
3,9						12,5	19,5	31	1	50	26395	27395	25395					
4,7											26475	27475	25475					
5,6	15,4	22,1	31	1	50	26565	27565	25565										
6,8						26685	27685	25685										

Table 2-U_R (d.c.) = 250 V; max. a.c. voltage = 160 V; Fig. 1

rated capacitance μF	T_{max}	H_{max}	L_{max}	d	ℓ min	mass g	catalogue number 2222 341				
							tol. \pm 20%	tol. \pm 10%	tol. \pm 5%		
0,039	5,1	8,8	14,6	0,8	40	1,0	88393	89393	87393		
0,047							88473	89473	87473		
0,056							88563	89563	87563		
0,068	88683	89683	87683								
0,082	5,7	9,5	14,6				1,1	88823	89823	87823	
0,10								88104	89104	87104	
0,12	6,6	10,4	18,1			1	50	1,7	88124	89124	87124
0,15									88154	89154	87154
0,18									88184	89184	87184
0,22								88224	89224	87224	
0,27	7,8	11,6	23,5					2,5	88274	89274	87274
0,33									88334	89334	87334
0,39				88394	89394				87394		
0,47	9,2	12,9	23,5	3,2	88474			89474	87474		
0,56					88564			89564	87564		
0,68					88684			89684	87684		
0,82	10,7	14,6	31	5,5	88824			89824	87824		
1,0					88105			89105	87105		
1,2					88125	89125	87125				
1,5	12,5	19,5	31		8,0	88155	89155	87155			
1,8						88185	89185	87185			
2,2						88225	89225	87225			

Table 3-U_R (d.c.) = 400 V; max. a.c. voltage = 220 V; Fig. 1

rated capacitance μF	T _{max}	H _{max}	L _{max}	d	\varnothing min	mass g	catalogue number 2222 341												
							tol. \pm 20%	tol. \pm 10%	tol. \pm 5%										
0,0082	5,1	8,8	14,6	0,8	40	1,0	54822	55822	53822										
0,010							54103	55103	53103										
0,012							54123	55123	53123										
0,015							54153	55153	53153										
0,018							54183	55183	53183										
0,022							54223	55223	53223										
0,027						7	10,6	14,6	0,8	40	1,4	54273	55273	53273					
0,033												54333	55333	53333					
0,039												54393	55393	53393					
0,047											6,6	10,4	18,1	0,8	40	1,7	54473	55473	53473
0,056																	54563	55563	53563
0,068																	54683	55683	53683
0,082	7,9	11,5	18,1	0,8	40	2,0	54823	55823	53823										
0,10							54104	55104	53104										
0,12	7,8	11,6	23,5	0,8	40	2,5	54124	55124	53124										
0,15							54154	55154	53154										
0,18	9,2	12,9	23,5	0,8	40	3,2	54184	55184	53184										
0,22							54224	55224	53224										
0,27	10,8	14,5	23,5	0,8	40	4,0	54274	55274	53274										
0,33							54334	55334	53334										
0,39	10,7	14,6	31	1	50	5,5	54394	55394	53394										
0,47							54474	55474	53474										
0,56	12,5	19,5	31	1	50	8,0	54564	55564	53564										
0,68							54684	55684	53684										
0,82	15,4	22,1	31	1	50	10,5	54824	55824	53824										
1,0							54105	55105	53105										

Marking

- a. Rated capacitance
- b. Rated voltage
- c. Tolerance on rated capacitance
- d. Category voltage
- e. Year and month of manufacture
- f. Manufacturer's name
- g. Climatic category
- h. Manufacturer's type designation

The marking is impressed on one side with a, b, c, e and h as follows:

1st line : rated capacitance in pF or μ F, tolerance and rated d.c. voltage;

2nd line: 5th, 6th and 7th digits of the catalogue number, code for dielectric material (MKT) and production date code (according to IEC 62, clause 5).

The marking on the other side is impressed with f as follows:

1st line : manufacturer's name;

2nd line : code for factory of origin.

The package containing the capacitors is marked with a to h.

Mounting

The capacitors are for horizontal or vertical mounting on printed-wiring boards and for point to point wiring.

Ratings and characteristics

Unless otherwise specified all electrical values apply to an ambient free air temperature of $23 \pm 1 \text{ }^\circ\text{C}$, an atmospheric pressure of 86 to 106 kPa and a relative humidity of $50 \pm 2\%$.

Capacitance

Rated capacitance range at 1 kHz

see Tables 1 to 3

Tolerance on rated capacitance

see Tables 1 to 3

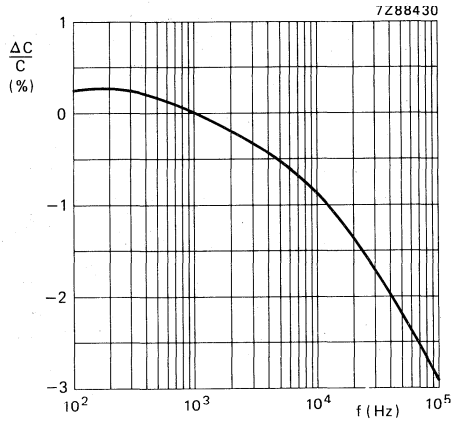

Fig. 2 Capacitance as a function of frequency; typical curve.

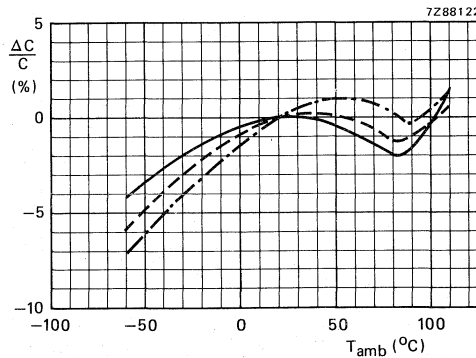

Fig. 3 Capacitance as a function of ambient free air temperature; typical curves.

- for all capacitance values, measured at 1 kHz, 1 V.
- - - for capacitance values $\leq 1 \mu\text{F}$, measured at 10 kHz, 1 V.
- · - · for capacitance values $\leq 0,1 \mu\text{F}$, measured at 100 kHz, 0,3 V.

Voltage

Rated voltage U_R (d.c.)	See Tables 1 to 3
Category voltage U_C	$0,8 \times U_R$ (d.c.)
Maximum a.c. voltage (r.m.s. value), at 50 to 60 Hz	See Tables 1 to 3
Test voltage between terminations	$1,6 \times U_R$ (d.c.)
between interconnected terminations and case	$2 \times U_R$ (d.c.); min. 200 V

Temperature

Climatic category	55/100/56
Rated temperature	85 °C
Storage temperature range	-55 to + 100 °C

Notes

- The sum of the d.c. voltage and the peak value of the superimposed a.c. voltage must be $\leq U_R$ (d.c.).
- For waveforms other than sinusoidal the maximum permissible dissipation must not be exceeded.

Maximum pulse load

rated voltage V	maximum pulse load (V/ μ s)			
	L = 14,5 mm	L = 18 mm	L = 23,5 mm	L = 31 mm
100	24	10	6	3,5
250	35	14	9	5
400	55	22	14	8

The maximum pulse load values in the table are valid for pulse voltages equal to the rated voltage.

For lower pulse voltages the given values may be multiplied by U_R /applied voltage.

Note

If the pulse load requirement is satisfied, a check must be made to ascertain that the maximum dissipation is not exceeded.

Tangent of loss angle

capacitance	tangent of loss angle		
	1 kHz	10 kHz	100 kHz
$C_R \leq 0,1 \mu F$	$\leq 75 \times 10^{-4}$	$\leq 130 \times 10^{-4}$	$\leq 250 \times 10^{-4}$
$0,1 \mu F < C_R \leq 1 \mu F$	$\leq 75 \times 10^{-4}$	$\leq 130 \times 10^{-4}$	
$C_R > 1 \mu F$	$\leq 75 \times 10^{-4}$	$\leq 150 \times 10^{-4}$	

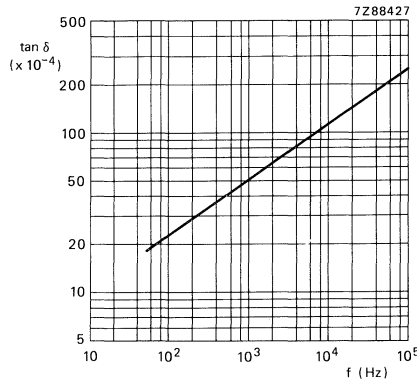

Fig. 4 Tan δ as a function of frequency, typical curve.

Insulation resistance

The insulation resistance is measured after a voltage of 100 ± 15 V has been applied for $1 \text{ min} \pm 5$ s, at $T_{\text{amb}} = 20$ °C.

R between terminations, for $C_R \leq 0,33 \mu F$

100 V version

> 15 000 M Ω

250 V and 400 V versions

> 30 000 M Ω

RC between terminations, for $C_R > 0,33 \mu F$

100 V version

> 5 000 s

250 V and 400 V versions

> 10 000 s

R between interconnected terminations and case (foil method)

> 30 000 M Ω

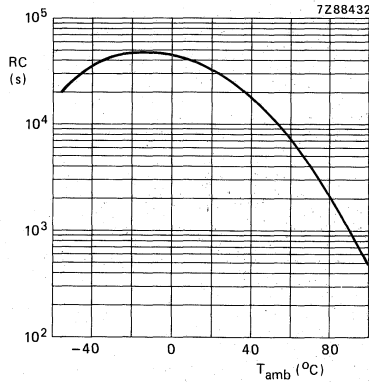

Fig. 5 RC-product as a function of ambient free air temperature; typical curve.

Maximum dissipation

Notes

In applications where voltages higher than 50 V are applied, it is recommended that the power in the capacitor be limited to 2,5 VA in case of capacitor failure.

If the requirement for the maximum dissipation is satisfied, a check must be made to ascertain that the maximum pulse load is not exceeded.

The maximum a.c. voltage has been specified for 50 to 60 Hz and at 23 °C. This voltage value must also never be exceeded at other frequencies. This permissible a.c. voltage may further be limited by the following requirements:

1. The power dissipation must not exceed the specified limit P_{max} .
2. The steepness of the a.c. voltage must not exceed the specified limit.

The power dissipated by a capacitor is a function of the voltage across the series resistance (R_s) or of the current through the series resistance and is expressed by

$$P = \frac{V_{R_s}^2}{R_s} = I^2 R_s$$

$$V_{R_s}^2 = \frac{R_s^2}{R_s^2 + 1/\omega^2 C^2} V_{ac}^2$$

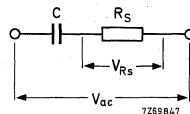

(1)
(2a)

Because for these capacitors $\tan \delta = R_s \omega C = < 0,1$, the formula (2a) can be simplified to

$$V_{R_s}^2 = \frac{R_s^2}{1/\omega^2 C^2} V_{ac}^2 = R_s^2 \omega^2 C^2 V_{ac}^2 \tag{2b}$$

Thus $P = R_s \omega^2 C^2 V_{ac}^2 \tag{3a}$

or $P = (R_s C) C \omega^2 V_{ac}^2 \tag{3b}$

The term $R_s C$ can be found from Fig. 6, C (in farads), $\omega = 2\pi f$ and V_{ac} are assumed to be known.

The maximum permissible value of power dissipation (P_{max}), which depends on the dimensions of the capacitor and on the ambient free air temperature, can be read from Fig. 7.

Thus, when the actual power has been calculated with equation (3b), Fig. 7 gives the minimum size of capacitor which can dissipate this power.

Example of using Figs 6 and 7

A capacitor of $1 \mu F$ should be used at an a.c. voltage of 130 V, a frequency of 1 kHz and an ambient free air temperature of $50^\circ C$.

The $R_s C$ -product is $7,1 \times 10^{-7} \Omega F$ (from Fig. 6), so that the power to be dissipated is

$$\begin{aligned} P &= (R_s C) C \omega^2 V_{ac}^2 \\ &= 7,1 \cdot 10^{-7} \times 1 \cdot 10^{-6} \times (2\pi)^2 \times 10^6 \times 130^2 \\ &= 472 \text{ mW} \end{aligned}$$

For a rated voltage of 130 Vac a capacitor of the 250 V range is required at least.

Capacitor $1 \mu F/160 \text{ Vac}$ is satisfactory because of its dimensions 10,7 mm x 14,6 mm x 31 mm and its dissipated power of 595 mW at $50^\circ C$.

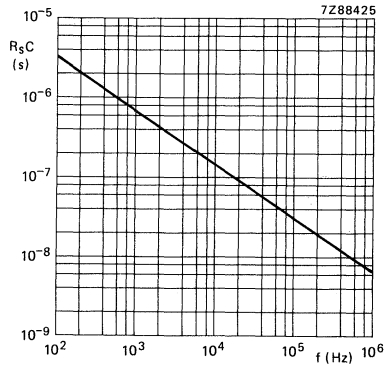

Fig. 6 Maximum product of series resistance and capacitance as a function of frequency.

curve	dimensions (mm)		
	T _{max}	H _{max}	L _{max}
1	5,1	8,8	14,6
2	5,7	9,5	14,6
3	7	10,6	14,6
4	6,6	10,4	18,1
5	7,9	11,5	18,1
6	7,8	11,6	23,5
7	9,2	12,9	23,5
8	10,8	14,5	23,5
9	10,7	14,6	31
10	12,5	19,5	31
11	15,4	22,1	31

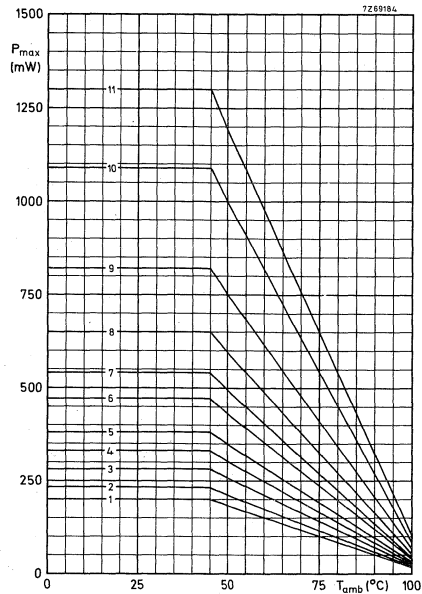

Fig. 7 Maximum dissipation as a function of ambient free air temperature.

ORDERING INFORMATION

Order the capacitors by quoting the 12-digit catalogue number as shown in Tables 1 to 3.

PACKING

The capacitors are packed in boxes of 250 (for H_{max} ≤ 11,5 mm) and 200 (for H_{max} > 11,5 mm).

METALLIZED POLYETHYLENETEREPHTHALATE FILM CAPACITORS

MKT radial potted type





- 5,08 to 27,5 mm pitch
- Supplied on tape or in boxes

QUICK REFERENCE DATA

Rated capacitance range (E12-series)	0,0039 to 10 μ F
Tolerance on rated capacitance	$\pm 20\%$, $\pm 10\%*$
Rated voltage U_R (d.c.)	63 V, 100 V, 250 V, 400 V
Climatic category	55/100/56
Rated temperature	85 $^{\circ}$ C
Tangent of the loss angle at 10 kHz	100×10^{-4}
Related specification	IEC 384-2
Performance grade	long life
Qualified according to	 CECC 30 401-039**

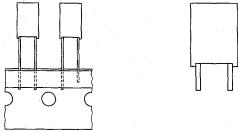
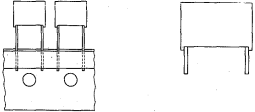
SURVEY OF STYLES

	style	pitch	tables
	2222 370	5,08 mm	1 to 2
	2222 371	7,62 mm	3 to 6
	2222 344	10 to 27,5 mm	7 to 10

APPLICATION

In electronic circuits for blocking and coupling, bypass and energy reservoir applications. Their defined dimensions make them suitable for circuits with high packaging density.

DESCRIPTION

The capacitors consist of a low-inductance wound cell of metallized polyethyleneterephthalate (PETP) film. The cell is potted with epoxy resin in a flame retardent polypropylene case. The radial leads are of solder-coated wire. The capacitors can withstand solvents and rinsing liquids without damage. They have small stand-off pips to allow removal of solder flux etc. during cleaning of the printed-wiring board.

* $\pm 5\%$ to special order.

** Except for 63 V version of style 2222 344.

2222 344
2222 370
2222 371

GENERAL DATA

Dimensions in mm

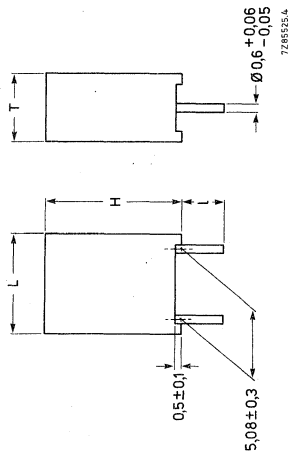

Fig. 1.

Table 1 UR (d.c.) = 63 V; max. a.c. voltage = 40 V; Fig. 1.

rated capacitance μF	T_{max}	H_{max}	L_{max}	mass	catalogue number 2222 370											
					packed in boxes				on tape on reel		on tape in ammunition pack					
					$I = 4 \pm 0.5$	$I = 25 + 2$	tol. $\pm 10\%$	tol. $\pm 10\%$	tol. $\pm 20\%$	tol. $\pm 10\%$	tol. $\pm 20\%$	tol. $\pm 10\%$	tol. $\pm 20\%$	tol. $\pm 10\%$	tol. $\pm 10\%$	
0,039				9	10393	11393	14393	15393	17393	18393	18393	17393	77393	78393		
0,047					10473	11473	14473	15473	17473	18473	18473	17473	77473	78473		
0,056	2,5	6	7,2	0,25	10563	11563	14563	15563	17563	18563	18563	17563	77563	78563		
0,068					10683	11683	14683	15683	17683	18683	18683	17683	77683	78683		
0,082					10823	11823	14823	15823	17823	18823	18823	17823	77823	78823		
0,10					10104	11104	14104	15104	17104	18104	18104	17104	77104	78104		
0,12					10124	11124	14124	15124	17124	18124	18124	17124	77124	78124		
0,15	3,5	8	7,2	0,35	10154	11154	14154	15154	17154	18154	18154	17154	77154	78154		
0,18					10184	11184	14184	15184	17184	18184	18184	17184	77184	78184		
0,22					10224	11224	14224	15224	17224	18224	18224	17224	77224	78224		
0,27					10274	11274	14274	15274	17274	18274	18274	17274	77274	78274		
0,33	4,5	9	7,2	0,45	10334	11334	14334	15334	17334	18334	18334	17334	77334	78334		
0,39	5	10	7,2	0,5	10394	11394	14394	15394	17394	18394	18394	17394	77394	78394		
0,47					10474	11474	14474	15474	17474	18474	18474	17474	77474	78474		
0,56	6	11	7,2	0,6	10564	11564	14564	15564	17564	18564	18564	17564	77564	78564		
0,68					10684	11684	14684	15684	17684	18684	18684	17684	77684	78684		

Table 2 U_R (d.c.) = 100 V; max. a.c. voltage = 63 V; Fig. 1.

rated capacitance μF	T _{max}	H _{max}	L _{max}	mass g	catalogue number 2222 370													
					packed in boxes					on tape on reel					on tape in ammunition pack			
					i = 4 ± 0,5		i = 25 + 2		tol. ± 10%	i = 4 ± 0,5		i = 25 + 2		tol. ± 10%	i = 4 ± 0,5		tol. ± 10%	tol. ± 10%
					tol. ± 20%	tol. ± 10%	tol. ± 20%	tol. ± 10%		tol. ± 20%	tol. ± 10%	tol. ± 20%	tol. ± 10%					
0,0039					20392	21392	24392	25392	27392	28392	87392	88392						
0,0047					20472	21472	24472	25472	27472	28472	87472	88472						
0,0056					20562	21562	24562	25562	27562	28562	87562	88562						
0,0068					20682	21682	24682	25682	27682	28682	87682	88682						
0,0082					20822	21822	24822	25822	27822	28822	87822	88822						
0,010	2,5	6	7,2	0,25	20103	21103	24103	25103	27103	28103	87103	88103						
0,012					20123	21123	24123	25123	27123	28123	87123	88123						
0,015					20153	21153	24153	25153	27153	28153	87153	88153						
0,018					20183	21183	24183	25183	27183	28183	87183	88183						
0,022					20223	21223	24223	25223	27223	28223	87223	88223						
0,027					20273	21273	24273	25273	27273	28273	87273	88273						
0,033					20333	21333	24333	25333	27333	28333	87333	88333						
0,039					20393	21393	24393	25393	27393	28393	87393	88393						
0,047					20473	21473	24473	25473	27473	28473	87473	88473						
0,056	3,5	8	7,2	0,35	20563	21563	24563	25563	27563	28563	87563	88563						
0,068					20683	21683	24683	25683	27683	28683	87683	88683						
0,082					20823	21823	24823	25823	27823	28823	87823	88823						
0,10					20104	21104	24104	25104	27104	28104	87104	88104						

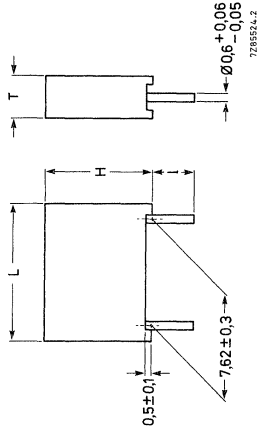

Fig. 2.

Table 3 UR (d.c.) = 63 V; max. a.c. voltage = 40 V; Fig. 2.

rated capacitance μF	T_{max}	H_{max}	L_{max}	mass g	catalogue number 2222 371					
					$l = 4 \pm 0,5$		$l = 25 + 2$		on tape on reel	
					tol. $\pm 20\%$	tol. $\pm 10\%$	tol. $\pm 20\%$	tol. $\pm 10\%$	tol. $\pm 20\%$	tol. $\pm 10\%$
0,056					10563	11563	14563	15563	17563	18563
0,068					10683	11683	14683	15683	17683	18683
0,082	2,5	6	10	0,3	10823	11823	14823	15823	17823	18823
0,10					10104	11104	14104	15104	17104	18104
0,12					10124	11124	14124	15124	17124	18124
0,15					10154	11154	14154	15154	17154	18154
0,18	3	8	10	0,4	10184	11184	14184	15184	17184	18184
0,22					10224	11224	14224	15224	17224	18224
0,27					10274	11274	14274	15274	17274	18274
0,33					10334	11334	14334	15334	17334	18334
0,39	4	9	10	0,5	10394	11394	14394	15394	17394	18394
0,47					10474	11474	14474	15474	17474	18474
0,56	5	10,5	10	0,65	10564	11564	14564	15564	17564	18564
0,68					10684	11684	14684	15684	17684	18684
0,82	6	11,5	10	0,75	10824	11824	14824	15824	17824	18824
1,0					10105	11105	14105	15105	17105	18105

Table 4 U_R (d.c.) = 100 V; max. a.c. voltage = 63 V; Fig. 2

rated capacitance μF	T _{max}	H _{max}	L _{max}	mass g	catalogue number 2222 371					
					l = 4 ± 0,5		l = 25 + 2		on tape on reel	
					tol. ± 20%	tol. ± 10%	tol. ± 20%	tol. ± 10%	tol. ± 20%	tol. ± 10%
0,018					20183	21183	24183	25183	27183	28183
0,022					20223	21223	24223	25223	27223	28223
0,027					20273	21273	24273	25273	27273	28273
0,033	2,5	6	10	0,3	20333	21333	24333	25333	27333	28333
0,039					20393	21393	24393	25393	27393	28393
0,047					20473	21473	24473	25473	27473	28473
0,056					20563	21563	24563	25563	27563	28563
0,068					20683	21683	24683	25683	27683	28683
0,082	3	8	10	0,4	20823	21823	24823	25823	27823	28823
0,10					20104	21104	24104	25104	27104	28104
0,12					20124	21124	24124	25124	27124	28124
0,15					20154	21154	24154	25154	27154	28154
0,18	4	9	10	0,5	20184	21184	24184	25184	27184	28184
0,22					20224	21224	24224	25224	27224	28224
0,27					20274	21274	24274	25274	27274	28274
0,33	5	10,5	10	0,65	20334	21334	24334	25334	27334	28334
0,39					20394	21394	24394	25394	27394	28394
0,47	6	11,5	10	0,75	20474	21474	24474	25474	27474	28474

Table 5 U_R (d.c.) = 250 V; max. a.c. voltage = 160 V; Fig. 2.

rated capacitance μF	T_{max}	H_{max}	L_{max}	mass g	catalogue number 2222 371					
					$l = 4 \pm 0,5$		$l = 25 + 2$		on tape on reel	
					tol. $\pm 20\%$	tol. $\pm 10\%$	tol. $\pm 20\%$	tol. $\pm 10\%$	tol. $\pm 20\%$	tol. $\pm 10\%$
0,0082					40822	41822	44822	45822	47822	48822
0,010	2,5	6	10	0,3	40103	41103	44103	45103	47103	48103
0,012					41123	44123	45123	47123	48123	
0,015					40153	41153	44153	45153	47153	48153
0,018					40183	41183	44183	45183	47183	48183
0,022	3	8	10	0,4	40223	41223	44223	45223	47223	48223
0,027					40273	41273	44273	45273	47273	48273
0,033					40333	41333	44333	45333	47333	48333

Table 6 U_R (d.c.) = 400 V; max. a.c. voltage = 220 V; Fig. 2.

rated capacitance μF	T_{max}	H_{max}	L_{max}	mass g	catalogue number 2222 371					
					$l = 4 \pm 0,5$		$l = 25 + 2$		on tape on reel	
					tol. $\pm 20\%$	tol. $\pm 10\%$	tol. $\pm 20\%$	tol. $\pm 10\%$	tol. $\pm 20\%$	tol. $\pm 10\%$
0,0039					50392	51392	54392	55392	57392	58392
0,0047	2,5	6	10	0,3	50472	51472	54472	55472	57472	58472
0,0056					50562	51562	54562	55562	57562	58562
0,0068					50682	51682	54682	55682	57682	58682
0,0082	3	8	10	0,4	50822	51822	54822	55822	57822	58822
0,010					50103	51103	54103	55103	57103	58103

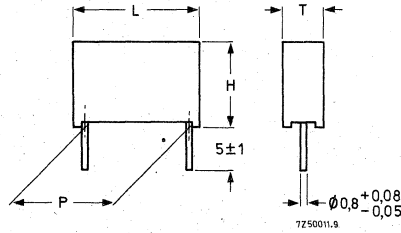

Fig. 3.

Table 7 U_R (d.c.) = 63 V; max. a.c. voltage = 40 V; Fig. 3.

rated capacitance μF	T_{max}	H_{max}	L_{max}	P	mass g	catalogue number 2222 344	
						tol. $\pm 20\%$	tol. $\pm 10\%$
0,18	4,5	10	13	$10 \pm 0,3$	0,7	14184	15184
0,22	4,5	10				14224	15224
0,27	5	11			14274	15274	
0,33	5	11			14334	15334	
0,39	6	12			14394	15394	
0,47	6	12			14474	15474	
0,56	6	11,5	17,5	$15 \pm 0,3$	1,4	14564	15564
0,68	6	11,5				14684	15684
0,82	7	13			14824	15824	
1,0	7	13			14105	15105	
1,2	8,5	14,5			14125	15125	
1,5	8,5	14,5			14155	15155	
1,8	6,5	15,5	26	$22,5 \pm 0,3$	2,75	14185	15185
2,2	6,5	15,5				14225	15225
2,7	8,5	17,5			14275	15275	
3,3	8,5	17,5			14335	15335	
3,9	9,5	19			14395	15395	
4,7	9,5	19			14475	15475	
5,6	11	20	31	$27,5 \pm 0,3$	7,4	14565	15565
6,8	11	20				14685	15685
8,2	13	22,5			14825	15825	
10	13	22,5			14106	15106	

2222 344
2222 370
2222 371

→ Table 8 U_R (d.c.) = 100 V; max. a.c. voltage = 63 V; Fig. 3.

rated capacitance μF	T_{max}	H_{max}	L_{max}	P	mass g	catalogue number 2222 344	
						tol. $\pm 20\%$	tol. $\pm 10\%$
0,082	4,5	10	13	$10 \pm 0,3$	0,7	24823	25823
0,10	4,5	10				24104	25104
0,12	4,5	10				24124	25124
0,15	4,5	10				24154	25154
0,18	4,5	10				24184	25184
0,22	4,5	10			24224	25224	
0,27	5	11	17,5	$15 \pm 0,3$	1,05	24274	25274
0,33	5	11			24334	25334	
0,39	5	11			24394	25394	
0,47	5	11			24474	25474	
0,56	6	11,5			1,8	24564	25564
0,68	6	11,5			2,55	24684	25684
0,82	7	13			24824	25824	
1,0	7	13			24105	25105	
1,2	6,5	15,5	26	$22,5 \pm 0,3$	2,75	24125	25125
1,5	6,5	15,5			24155	25155	
1,8	8,5	17,5			4,3	24185	25185
2,2	8,5	17,5			24225	25225	
2,7	9,5	19			5,1	24275	25275
3,3	9,5	19			24335	25335	
3,9	11	20	31	$27,5 \pm 0,3$	7,4	24395	25395
4,7	11	20			24475	25475	
5,6	13	22,5			10,2	24565	25565
6,8	13	22,5			24685	25685	
8,2	15	25			24825	25825	
10	15	25			12,8	24106	25106

Table 9 U_R (d.c.) = 250 V; max. a.c. voltage = 160 V; Fig. 3.

rated capacitance μF	T_{max}	H_{max}	L_{max}	P	mass g	catalogue number 2222 344			
						tol. \pm 20%	tol. \pm 10%		
0,039	4,5	10	13	$10 \pm 0,3$	0,7	40393	41393		
0,047						40473	41473		
0,056						40563	41563		
0,068						40683	41683		
0,082						40823	41823		
0,10	5	11	17,5	$15 \pm 0,3$	1,05	40104	41104		
0,12	5	11				40124	41124		
0,15	5	11				40154	41154		
0,18	6	11,5				40184	41184		
0,22	6	11,5				40224	41224		
0,27	7	13			26	$22,5 \pm 0,3$	1,4	40274	41274
0,33	7	13					1,8	40334	41334
0,39	6,5	15,5					40394	41394	
0,47	6,5	15,5					40474	41474	
0,56	6,5	15,5					40564	41564	
0,68	6,5	15,5	31	$27,5 \pm 0,3$	2,75	40684	41684		
0,82	8,5	17,5			40824	41824			
1,0	8,5	17,5			4,4	40105	41105		
1,2	11	20			40125	41125			
1,5					40155	41155			
1,8			40185	41185					
2,2			40225	41225					

2222 344
 2222 370
 2222 371

Table 10 U_R (d.c.) = 400 V; max. a.c. voltage = 220 V; Fig. 3.

rated capacitance μF	T_{max}	H_{max}	L_{max}	P	mass g	catalogue number 2222 344	
						tol. \pm 20%	tol. \pm 10%
0,010	4,5	10	13	$10 \pm 0,3$	0,7	54103	55103
0,012						54123	55123
0,015						54153	55153
0,018						54183	55183
0,022						54223	55223
0,027						54273	55273
0,033						54333	55333
0,039	5	11	17,5	$15 \pm 0,3$	1,05	54393	55393
0,047	5	11			54473	55473	
0,056	6	11,5			1,4	54563	55563
0,068	6	11,5			54683	55683	
0,082	7	13			1,8	54823	55823
0,10	7	13			54104	55104	
0,12	8,5	14,5			54124	55124	
0,15	8,5	14,5			2,55	54154	55154
0,18	6,5	15,5			2,75	54184	55184
0,22	6,5	15,5			54224	55224	
0,27	7,5	16,5	26	$22,5 \pm 0,3$	54274	55274	
0,33	7,5	16,5			3,5	54334	55334
0,39	9,5	19			54394	55394	
0,47	9,5	19			5,1	54474	55474
0,56	11	20			54564	55564	
0,68	11	20	31	$27,5 \pm 0,3$	7,4	54684	55684
0,82	13	22,5			54824	55824	
1,0	13	22,5			10,2	54105	55105

Marking

- a. Rated capacitance
- b. Rated voltage
- c. Tolerance on rated capacitance
- d. Category voltage
- e. Year and month or week of manufacture
- f. Manufacturer's name
- g. Climatic category
- h. Manufacturer's type designation

- Styles 2222 370 and 2222 371:

The capacitors are laser marked

— on the top with a and c as follows:

rated capacitance in nF or μF , and tolerance code ($M = \pm 20\%$, $K = \pm 10\%$, $J = \pm 5\%$).

— on the side with b, e, f and h as follows:

1st line : rated d.c. voltage with unit symbol,

2nd line : code for dielectric material (MKT) and code for factory of origin,

3rd line : 5th, 6th and 7th digits of the catalogue number, and manufacturer's identification (PH),

4th line : production date code (year and week).

- Style 2222 344:

The capacitors are marked on the top by embossed print with a, b, c, f and h as follows:

1st line : rated capacitance in μF , tolerance and rated d.c. voltage.

2nd line : code for dielectric material (MKT), 5th, 6th and 7th digits of the catalogue number, and code for factory of origin.

The manufacturer's identification symbol is indicated at the left of this marking.

Mounting

The capacitors are for printed-wiring applications. The capacitors which are supplied on tape (2222 370, 2222 371) are suitable for mounting on printed-wiring boards by means of automatic insertion machines.

Ratings and characteristics

Unless otherwise specified all electrical values apply to an ambient free air temperature of $23 \pm 1 \text{ }^\circ\text{C}$, an atmospheric pressure of 86 to 106 kPa and a relative humidity of $50 \pm 2\%$.

Capacitance

Rated capacitance range at 1 kHz

see Tables 1 to 10

Tolerance on rated capacitance

see Tables 1 to 10

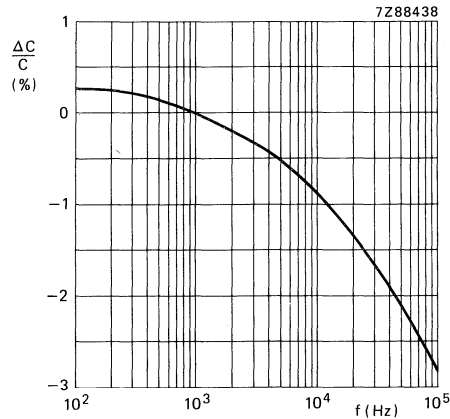

Fig. 4 Capacitance as a function of frequency; typical curve.

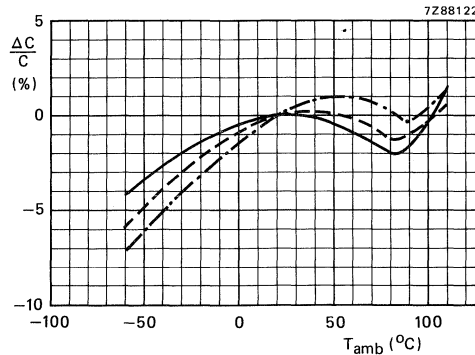

Fig. 5 Capacitance as a function of ambient free air temperature; typical curves.

- for all capacitance values, measured at 1 kHz, 1 V.
- for capacitance values $\leq 1 \mu\text{F}$, measured at 10 kHz, 1 V.
- · - · - for capacitance values $\leq 0,1 \mu\text{F}$, measured at 100 kHz, 0,3 V.

Voltage

Rated voltage U_R (d.c.)	See Tables 1 to 10
Category voltage U_C	$0,8 \times U_R$ (d.c.)
Maximum a.c. voltage (r.m.s. value), at 50 to 60 Hz	See Tables 1 to 10
Test voltage between terminations	$1,6 \times U_R$ (d.c.)
between interconnected terminations and case	$2 \times U_R$ (d.c.); min. 200 V

Temperature

Climatic category	55/100/56
Rated temperature	85 °C
Storage temperature range	-55 to + 100 °C

Notes

- The sum of the d.c. voltage and the peak value of the superimposed a.c. voltage must be $\leq U_R$ (d.c.)
- For waveforms other than sinusoidal the maximum permissible dissipation must not be exceeded.

Maximum pulse load

rated voltage V	maximum pulse load (V/ μ s)					
	L = 7,2 mm	L = 10 mm	L = 13 mm	L = 17,5 mm	L = 26 mm	L = 31 mm
63	55	17	15	6	3	2
100	90	30	24	10	4	3,5
250		60	35	14	6	5
400		95	55	22	10	8

The maximum pulse load values in the table are valid for pulse voltages equal to the rated voltage.

For lower pulse voltages the given values may be multiplied by U_R /applied voltage.

Note

If the pulse load requirement is satisfied, a check must be made to ascertain that the maximum dissipation is not exceeded.

Tangent of loss angle

capacitance	tangent of loss angle		
	1 kHz	10 kHz	100 kHz
$C \leq 0,1 \mu\text{F}$	$\leq 75 \times 10^{-4}$	$\leq 130 \times 10^{-4}$	$\leq 225 \times 10^{-4}$
$0,1 \mu\text{F} < C \leq 0,47 \mu\text{F}$	$\leq 75 \times 10^{-4}$	$\leq 130 \times 10^{-4}$	$\leq 300 \times 10^{-4}^*$
$0,47 \mu\text{F} < C \leq 1 \mu\text{F}$	$\leq 75 \times 10^{-4}$	$\leq 130 \times 10^{-4}$	
$C > 1 \mu\text{F}$	$\leq 75 \times 10^{-4}$	$\leq 150 \times 10^{-4}$	

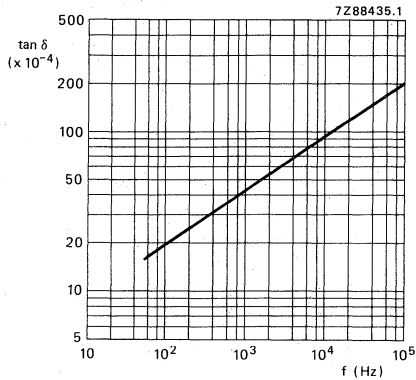

Fig. 6 Tan δ as a function of frequency, typical curve.

Insulation resistance

The insulation resistance is measured after a voltage has been applied for 1 min \pm 5 s, the voltage being 10 \pm 1 V for the 63 V version and 100 \pm 15 V for the 100 V, 250 V and 400 V versions at $T_{\text{amb}} = 20^\circ\text{C}$.

R between terminations, for $C_R \leq 0,33 \mu\text{F}$

63 V and 100 V versions

> 15 000 M Ω

250 V and 400 V versions

> 30 000 M Ω

RC between terminations, for $C_R > 0,33 \mu\text{F}$

63 V and 100 V versions

> 5 000 s

250 V and 400 V versions

> 10 000 s

R between interconnected terminations and case (foil method)

> 30 000 M Ω

* Only for 2222 370 and 2222 371.

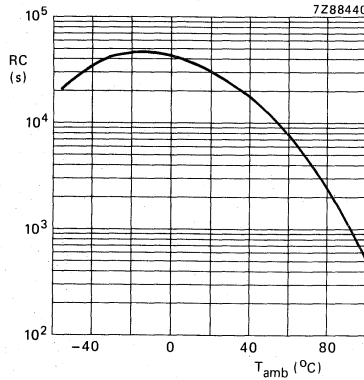

Fig. 7 RC-product as a function of ambient free air temperature; typical curve.

Maximum dissipation

Notes

In applications where voltages higher than 50 V are applied, it is recommended that the power in the capacitor be limited to 2,5 VA in case of capacitor failure.

If the requirement for the maximum permissible power dissipation is satisfied, a check must be made to ascertain that the maximum permissible pulse load is not exceeded.

The maximum a.c. voltage has been specified for 50 to 60 Hz and at 23 °C. This voltage value must also never be exceeded at other frequencies. This permissible a.c. voltage may further be limited by the following requirements:

1. The power dissipation must not exceed the specified limit P_{max} .
2. The steepness of the a.c. voltage must not exceed the specified limit.

The power dissipated by a capacitor is a function of the voltage across the series resistance (R_s) or of the current through the series resistance and is expressed by

$$P = \frac{V_{R_s}^2}{R_s} = I^2 R_s \tag{1}$$

$$V_{R_s}^2 = \frac{R_s^2}{R_s^2 + 1/\omega^2 C^2} V_{ac}^2 \tag{2a}$$

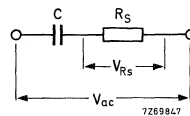

Because for these capacitors $\tan \delta = R_s \omega C = < 0,1$, the formula (2a) can be simplified to

$$V_{R_s}^2 = \frac{R_s^2}{1/\omega^2 C^2} V_{ac}^2 = R_s^2 \omega^2 C^2 V_{ac}^2 \tag{2b}$$

Thus $P = R_s \omega^2 C^2 V_{ac}^2 \tag{3a}$

or $P = (R_s C) C \omega^2 V_{ac}^2 \tag{3b}$

The term $R_s C$ can be found from Fig. 8, C (in farads), $\omega = 2\pi f$ and V_{ac} are assumed to be known.

The maximum permissible value of power dissipation (P_{max}), which depends on the dimensions of the capacitor and on the ambient free air temperature, can be read from Fig. 9.

Thus, when the actual power has been calculated with equation (3b), Fig. 9 gives the minimum size of capacitor which can dissipate this power.

Example of using Figs 8 and 9

A capacitor of $0,1 \mu F$ should be used at an a.c. voltage of 10 V, a frequency of 10 kHz and an ambient temperature of $50^\circ C$.

The $R_s C$ -product is $2 \times 10^{-7} \Omega F$ (from Fig. 8), so that the power to be dissipated is

$$\begin{aligned}
 P &= (R_s C) C \omega^2 V_{ac}^2 \\
 &= 2 \cdot 10^{-7} \times 0,1 \cdot 10^{-6} \times (2\pi)^2 \times 10^8 \times 10^2 W \\
 &= 7,8 \text{ mW}
 \end{aligned}$$

For a rated voltage of 10 Vac a capacitor of the 63 V version is required at least.

Capacitor $0,1 \mu F/40 \text{ Vac}$ is satisfactory because of its dimensions $2,5 \text{ mm} \times 6 \text{ mm} \times 7,2 \text{ mm}$ and its dissipated power of 57 mW at $50^\circ C$.

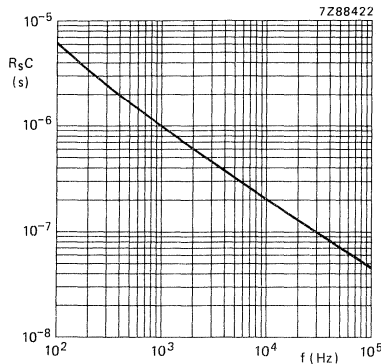

Fig. 8 Maximum product of series resistance and capacitance as a function of frequency.

curve	dimensions (mm)		
	T _{max}	H _{max}	L _{max}
1	2,5	6	7,2
2	2,5	6	10
3	3,5	8	7,2
4	4,5	9	7,2
5	5	10	7,2
6	4	9	10
7	6	11	7,2
	5	10,5	10
8	4,5	10	13
9	6	11,5	10
10	5	11	13
11	5	11	13
12	6	12	13
13	5	11	17,5
14	6	11,5	17,5
15	7	13	17,5
16	8,5	14,5	17,5
17	6,5	15,5	26
18	7,5	16,5	26
19	8,5	17,5	26
20	9,5	19	26
	11	20	31
	13	22,5	31
	15	25	31

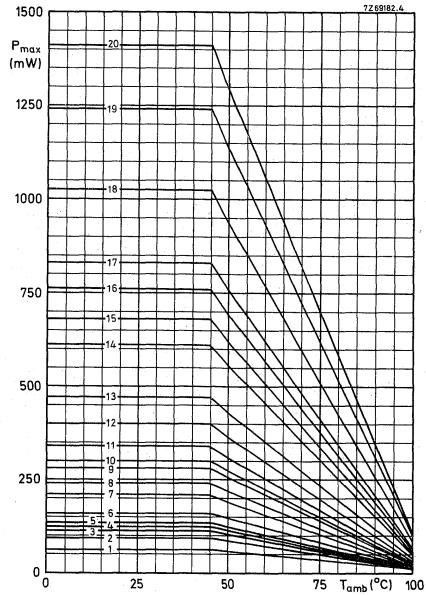

Fig. 9 Maximum dissipation as a function of ambient free air temperature.

ORDERING INFORMATION

Order the capacitors by quoting the 12-digit catalogue number as shown in Tables 1 to 10.

2222 344
 2222 370
 2222 371

PACKING

Style 2222 344

The capacitors are supplied in boxes of 1000 (L < 31 mm) or 500 (L = 31 mm).

Style 2222 370

The capacitors are supplied in boxes, and on tape on reel or in ammunition packing.

The number of capacitors per box is 2000 for l = 4 ± 0,5 mm, and 1000 for l = 25 + 2 mm.

The number of capacitors per reel and per ammunition packing is 2000 for T = 2,5 mm, 1500 for T = 3,5 mm, and 1000 for T ≥ 4,5 mm.

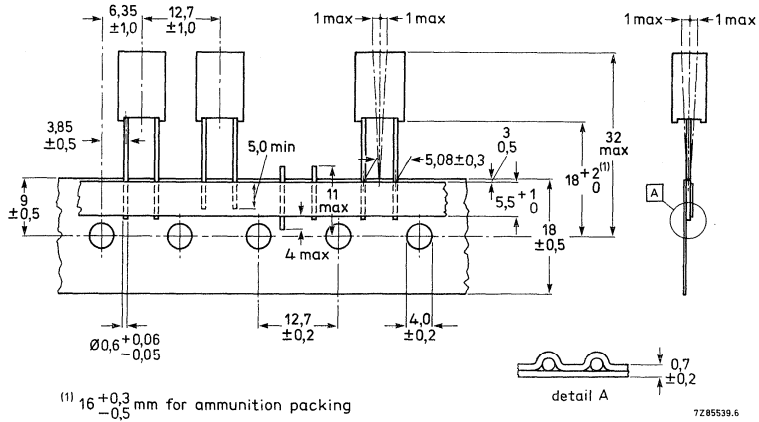

Fig. 10 Capacitors 2222 370 on tape.

Cumulative pitch error: 1,0 mm/20 pitches.

Max. 0,5% of the total number of capacitors per reel may be missing, but no more than 2 consecutive positions may be vacant.

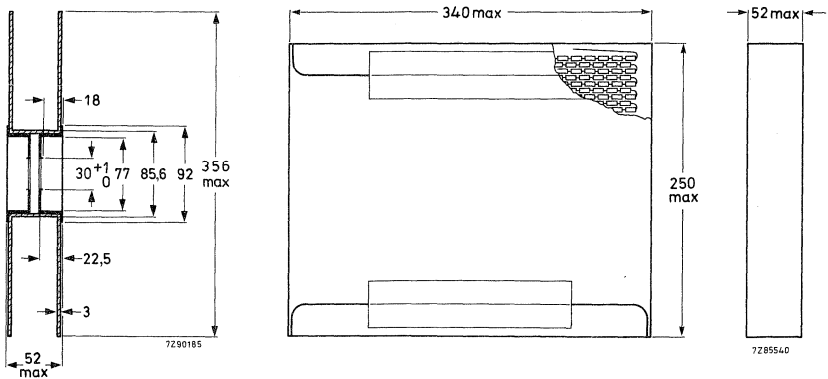

Fig. 11 Reel.

Fig. 12 Capacitors on tape in ammunition packing.

Style 2222 371

The capacitors are supplied in boxes of 1000, and on tape on reels of 1500 for $T \leq 4$ mm, and 1000 for $T > 4$ mm.

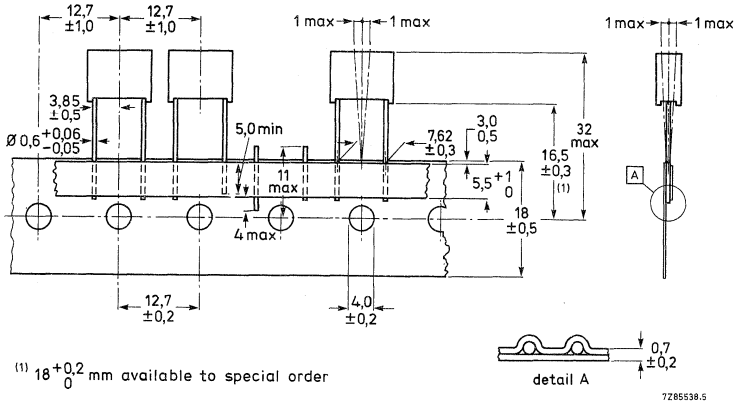

Fig. 13 Capacitors 2222 371 on tape.

Cumulative pitch error 1,0 mm/20 pitches.

Max. 0,5% of the total number of capacitors per reel may be missing, but no more than 2 consecutive positions may be vacant.

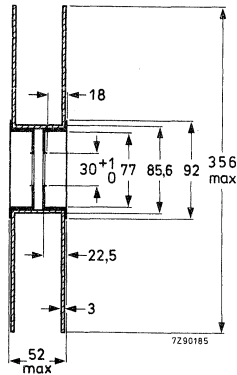

Fig. 14 Reel.

2222 344
2222 370
2222 371

Characteristics concerning taped capacitors:

Pull-out force of the component

≥ 5 N

Pull-off force of adhesive tape

≥ 6 N

Tearing force of tape

≥ 15 N

Storage conditions:

Storage temperature range

-25 to + 40 °C

Relative humidity

$\leq 80\%$

METALLIZED POLYETHYLENETEREPHTHALATE FILM CAPACITORS

MKT radial epoxy lacquered type

- 5,08 to 27,94 mm pitch
- Supplied on tape or in boxes

QUICK REFERENCE DATA

Rated capacitance range (E12-series)	0,001 to 6,8 μ F
Tolerance on rated capacitance	$\pm 20\%$, $\pm 10\%*$
Rated voltage U_R (d.c.)	63 V, 100 V, 250 V, 400 V, 630 V
Climatic category	40/100/56
Rated temperature	85 °C
Tangent of the loss angle at 10 kHz	100×10^{-4}
Related specification	IEC 384-2
Performance grade	long life

SURVEY OF STYLES

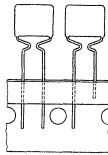

style	pitch	tables
2222 365	5,08 mm	1 to 6
2222 366	5,08 mm; 7,62 mm	7 to 12
2222 368	10,16 mm to 27,94 mm	13 to 16
2222 367	5,08 mm; 7,62 mm	17 to 22
2222 369	10,16 mm	23 to 26

APPLICATION

In electronic circuits for blocking and coupling, bypass and energy reservoir applications. Their small dimensions make them suitable for circuits with high packaging density.

DESCRIPTION

The capacitors consist of a low-inductance wound cell of metallized polyethyleneterephthalate film. The cell is protected by a hard, water repellent, solvent resistant epoxy lacquer. The radial leads are of solder-coated wire.

* $\pm 5\%$ to special order.

GENERAL DATA

Dimensions in mm

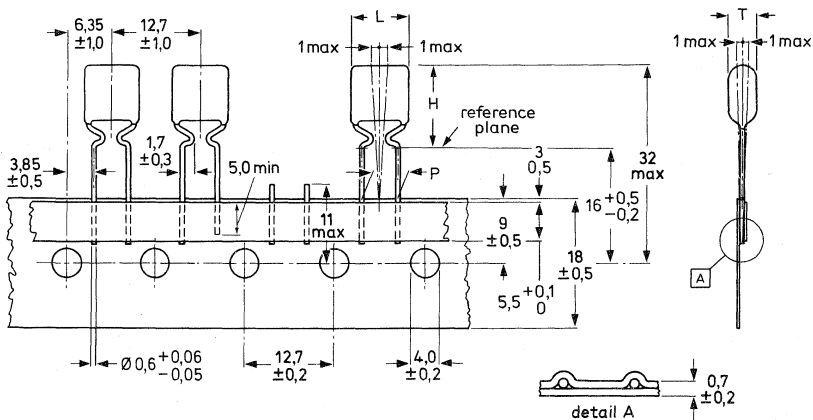

Fig. 1.

Table 1 U_R (d.c.) = 63 V; max. a.c. voltage = 40 V; Fig. 1; pitch = 5,08 mm

rated capacitance μF	T_{max}	H_{max}	L_{max}	P	mass g	catalogue number 2222 365			
						reel packing		ammunition packing	
						tol. $\pm 20\%$	tol. $\pm 10\%$	tol. $\pm 20\%$	tol. $\pm 10\%$
0,047	3,5	12,5	7,5	5,08 \pm 0,3	0,3	70473	71473	74473	75473
0,056						70563	71563	74563	75563
0,068						70683	71683	74683	75683
0,082						70823	71823	74823	75823
0,1						70104	71104	74104	75104
0,12						70124	71124	74124	75124
0,15						70154	71154	74154	75154
0,18						70184	71184	74184	75184
0,22						70224	71224	74224	75224
0,27						70274	71274	74274	75274
0,33	5,5	14,5	7,5	0,45	70334	71334	74334	75334	
0,39					70394	71394	74394	75394	
0,47					70474	71474	74474	75474	

Table 2 U_R (d.c.) = 100 V; max. a.c. voltage = 63 V; Fig. 1; pitch = 5,08 mm

rated capacitance μF	T_{max}	H_{max}	L_{max}	P	mass g	catalogue number 2222 365							
						reel packing		ammunition packing					
						tol. $\pm 20\%$	tol. $\pm 10\%$	tol. $\pm 20\%$	tol. $\pm 10\%$				
0,01	3,5	12,5	7,5	5,08 \pm 0,3	0,3	80103	81103	84103	85103				
0,012						80123	81123	84123	85123				
0,015						80153	81153	84153	85153				
0,018						80183	81183	84183	85183				
0,022						80223	81223	84223	85223				
0,027						80273	81273	84273	85273				
0,033						80333	81333	84333	85333				
0,039						80393	81393	84393	85393				
0,047						4	13	7,5	0,35	80473	81473	84473	85473
0,056						4,5	13,5	7,5		80563	81563	84563	85563
0,068	80683	81683	84683	85683									
0,082	80823	81823	84823	85823									
0,10					80104	81104	84104	85104					

Table 3 U_R (d.c.) = 63 V; max. a.c. voltage = 40 V; Fig. 1; original pitch 7,62 mm reduced to 5,08 mm

rated capacitance μF	T_{max}	H_{max}	L_{max}	P	mass g	catalogue number 2222 365			
						reel packing		ammunition packing	
						tol. $\pm 20\%$	tol. $\pm 10\%$	tol. $\pm 20\%$	tol. $\pm 10\%$
0,12	4	13,5	10	5,08 \pm 0,3	0,4	10124	11124	14124	15124
0,15						10154	11154	14154	15154
0,18						10184	11184	14184	15184
0,22						10224	11224	14224	15224
0,27						10274	11274	14274	15274
0,33	4,5	14	10,5	0,5	10334	11334	14334	15334	
0,39	5	14,5			10394	11394	14394	15394	
0,47	5,5	15			10474	11474	14474	15474	

Table 4 U_R (d.c.) = 100 V; max. a.c. voltage = 63 V; Fig. 1; original pitch 7,62 mm reduced to 5,08 mm

rated capacitance μF	T_{max}	H_{max}	L_{max}	P	mass g	catalogue number 2222 365							
						reel packing		ammunition packing					
						tol. $\pm 20\%$	tol. $\pm 10\%$	tol. $\pm 20\%$	tol. $\pm 10\%$				
0,039	4	13,5	10	5,08 \pm 0,3	0,4	20393	21393	24393	25393				
0,047						20473	21473	24473	25473				
0,056						20563	21563	24563	25563				
0,068						20683	21683	24683	25683				
0,082						20823	21823	24823	25823				
0,10						20104	21104	24104	25104				
0,12						4,5	14	10,5	0,5	20124	21124	24124	25124
0,15						5	14,5		0,5	20154	21154	24154	25154
0,18						5	14,5		0,6	20184	21184	24184	25184
0,22						5,5	15		0,7	20224	21224	24224	25224
0,27	6	15,5	0,7	20274	21274	24274	25274						

Table 5 U_R (d.c.) = 250 V; max. a.c. voltage = 160 V; Fig. 1; original pitch 7,62 mm reduced to 5,08 mm

rated capacitance μF	T_{max}	H_{max}	L_{max}	P	mass g	catalogue number 2222 365			
						reel packing		ammunition packing	
						tol. $\pm 20\%$	tol. $\pm 10\%$	tol. $\pm 20\%$	tol. $\pm 10\%$
0,018	4	13,5	10	5,08 \pm 0,3	0,4	40183	41183	44183	45183
0,022						40223	41223	44223	45223
0,027						40273	41273	44273	45273
0,033						40333	41333	44333	45333
0,039						40393	41393	44393	45393
0,047						40473	41473	44473	45473
						4,5	14	10,5	0,5

Table 6 U_R (d.c.) = 400 V; max. a.c. voltage = 220 V; Fig. 1; original pitch 7,62 mm reduced to 5,08 mm

rated capacitance μF	T_{max}	H_{max}	L_{max}	P	mass g	catalogue number 2222 365			
						reel packing		ammunition packing	
						tol. $\pm 20\%$	tol. $\pm 10\%$	tol. $\pm 20\%$	tol. $\pm 10\%$
0,0039	4	13,5	10	5,08 \pm 0,3	0,4	50392	51392	54392	55392
0,0047						50472	51472	54472	55472
0,0056						50562	51562	54562	55562
0,0068						50682	51682	54682	55682
0,0082						50822	51822	54822	55822
0,010						50103	51103	54103	55103
0,012						50123	51123	54123	55123
0,015						50153	51153	54153	55153

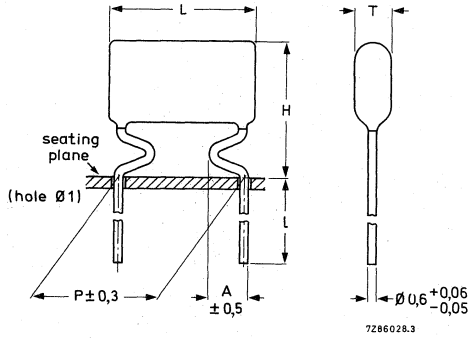

Fig. 2.

Table 7 U_R (d.c.) = 63 V; max. a.c. voltage = 40 V; Fig. 2; pitch = 5,08 mm

rated capacitance μF	T_{max}	H_{max}	L_{max}	A	P	mass g	catalogue number 2222 366						
							$\ell = 17 \pm 4$		$\ell = 5 \pm 1$				
							tol. $\pm 20\%$	tol. $\pm 10\%$	tol. $\pm 20\%$	tol. $\pm 10\%$			
0,047	3,5	12,5	7,5	1,7 \pm 0,3	5,08 \pm 0,3	0,3	70473	71473	74473	75473			
0,056							70563	71563	74563	75563			
0,068							70683	71683	74683	75683			
0,082							70823	71823	75823	75823			
0,1							70104	71104	74104	75104			
0,12							70124	71124	74124	75124			
0,15							4	13	7,5	70154	71154	74154	75154
0,18							4,5	13,5	7,5	70184	71184	74184	75184
0,22							70224	71224	74224	75224			
0,27							5	14	7,5	70274	71274	74274	75274
0,33	5,5	14,5	7,5			0,45	70334	71334	74334	75334			
0,39							70394	71394	74394	75394			
0,47							6	15,5	7,5	70474	71474	74474	75474

Table 8 U_R (d.c.) = 100 V; max. a.c. voltage = 63 V; Fig. 2; pitch = 5,08 mm

rated capacitance μF	T_{max}	H_{max}	L_{max}	A	P	mass g	catalogue number 2222 366			
							$\ell = 17 \pm 4$		$\ell = 5 \pm 1$	
							tol. $\pm 20\%$	tol. $\pm 10\%$	tol. $\pm 20\%$	tol. $\pm 10\%$
0,01	3,5	12,5	7,5	1,7 \pm 0,3	5,08 \pm 0,3	0,3	80103	81103	84103	85103
0,012							80123	81123	84123	85123
0,015							80153	81153	84153	85153
0,018							80183	81183	84183	85183
0,022							80223	81223	84223	85223
0,027							80273	81273	84273	85273
0,033							80333	81333	84333	85333
0,039							80393	81393	84393	85393
0,047							80473	81473	84473	85473
0,056							80563	81563	84563	85563
0,068	4,5	13,5	7,5			0,35	80683	81683	84683	85683
0,082							80823	81823	84823	85823
0,10							80104	81104	84104	85104

Table 9 U_R (d.c.) = 63 V; max. a.c. voltage = 40 V; Fig. 2 pitch = 7,62 mm

rated capacitance μF	T_{max}	H_{max}	L_{max}	A	P	mass g	catalogue number 2222 366			
							$\ell = 17 \pm 4$		$\ell = 5 \pm 1$	
							tol. $\pm 20\%$	tol. $\pm 10\%$	tol. $\pm 20\%$	tol. $\pm 10\%$
0,12	4	11	10	2,0 \pm 0,5	7,62 \pm 0,3	0,4	10124	11124	14124	15124
0,15							10154	11154	14154	15154
0,18							10184	11184	14184	15184
0,22							10224	11224	14224	15224
0,27							10274	11274	14274	15274
0,33	4,5	11,5	10,5			0,5	10334	11334	14334	15334
0,39	5	12	10,5				10394	11394	14394	15394
0,47	5,5	12,5	10,5				10474	11474	14474	15474

Table 10 U_R (d.c.) = 100 V; max. a.c. voltage = 63 V; Fig. 2; pitch = 7,62 mm

rated capacitance μF	T_{max}	H_{max}	L_{max}	A	P	mass g	catalogue number 2222 366										
							$\ell = 17 \pm 4$		$\ell = 5 \pm 1$								
							tol. $\pm 20\%$	tol. $\pm 10\%$	tol. $\pm 20\%$	tol. $\pm 10\%$							
0,039	4	11	10	2,0 \pm	7,62 \pm	0,4	20393	21393	24393	25393							
0,047							20473	21473	24473	25473							
0,056							20563	21563	24563	25563							
0,068							20683	21683	24683	25683							
0,082							20823	21823	24823	25823							
0,10				4,5	11,5	10,5	0,5	0,3	0,5	20104	21104	24104	25104				
0,12										20124	21124	24124	25124				
0,15										5	12	10,5	0,6	20154	21154	24154	25154
0,18										5	12	10,5	0,6	20184	21184	24184	25184
0,22										5,5	12,5	10,5	0,7	20224	21224	24224	25224
0,27	6	13	10,5	0,7	20274	21274	24274	25274									

Table 11 U_R (d.c.) = 250 V; max. a.c. voltage = 160 V; Fig. 2; pitch = 7,62 mm

rated capacitance μF	T_{max}	H_{max}	L_{max}	A	P	mass g	catalogue number 2222 366			
							$\ell = 17 \pm 4$		$\ell = 5 \pm 1$	
							tol. $\pm 20\%$	tol. $\pm 10\%$	tol. $\pm 20\%$	tol. $\pm 10\%$
0,018	4	11	10	2,0 \pm	7,62 \pm	0,4	40183	41183	44183	45183
0,022							40223	41223	44223	45223
0,027							40273	41273	44273	45273
0,033							40333	41333	44333	45333

Table 12 U_R (d.c.) = 400 V; max. a.c. voltage = 220 V; Fig. 2; pitch = 7,62 mm

rated capacitance μF	T_{max}	H_{max}	L_{max}	A	P	mass g	catalogue number 2222 366						
							$\ell = 17 \pm 4$		$\ell = 5 \pm 1$				
							tol. $\pm 20\%$	tol. $\pm 10\%$	tol. $\pm 20\%$	tol. $\pm 10\%$			
0,0039	4	11	10	2,0 \pm	7,62 \pm	0,4	50392	51392	54392	55392			
0,0047							50472	51472	54472	55472			
0,0056							50562	51562	54562	55562			
0,0068							50682	51682	54682	55682			
0,0082							50822	51822	54822	55822			
0,010				4,5	11,5	10,5	0,5	0,3	0,5	50103	51103	54103	55103
0,012										50123	51123	54123	55123
0,015										50153	51153	54153	55153

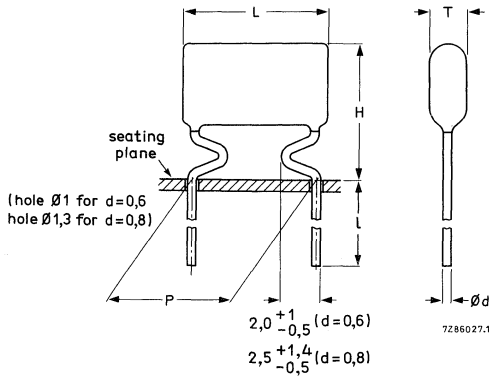

Fig. 3

pitch P	lead length ℓ	
	short leads	5 ± 1
10,16	long leads	17 ± 4
15,24		25 ± 4
22,86		24 ± 4
27,94		

Table 13 U_R (d.c.) = 100 V; max. a.c. voltage = 63 V, Fig. 3

rated capacitance μF	T_{max}	H_{max}	L_{max}	d	P	mass g	catalogue number 2222 368							
							short leads		long leads					
							tol. $\pm 20\%$	tol. $\pm 10\%$	tol. $\pm 20\%$	tol. $\pm 10\%$				
0,056	4	12	12,5	0,6 $+ 0,06$ $- 0,05$	10,16 $\pm 0,3$	0,4	24563	25563	20563	21563				
0,068							24683	25683	20683	21683				
0,082							24823	25823	20823	21823				
0,10							24104	25104	20104	21104				
0,12							24124	25124	20124	21124				
0,15		24154	25154			20154	21154							
0,18		4,5	12,5			17,5	0,8 $+ 0,08$ $- 0,05$	15,24 $\pm 0,3$	0,45	24184	25184	20184	21184	
0,22		5	13						0,5	24224	25224	20224	21224	
0,27		5	14						26	0,5	24274	25274	20274	21274
0,33										0,6	24334	25334	20334	21334
0,39	0,65			24394	25394					20394	21394			
0,47	0,75			24474	25474	20474				21474				
0,56	5,5			14,5	0,85	24564				25564	20564	21564		
0,68	6	15	30	1	24684	25684			20684	21684				
0,82	6,5	15,5		1,15	24824	25824			20824	21824				
1,0	7,5	16,5		1,35	24105	25105			20105	21105				
1,2	6	18		26	1,8	24125	25125	20125	21125					
1,5					2	24155	25155	20155	21155					
1,8			2,3		24185	25185	20185	21185						
2,2			2,8		24225	25225	20225	21225						
2,7			3,2		24275	25275	20275	21275						
3,3	6,5	18,5	30	22,86 $\pm 0,3$	4	24335	25335	20335	21335					
3,9	8,5	20,5			4,5	24395	25395	20395	21395					
4,7	9,5	21,5			5,2	24475	25475	20475	21475					
5,6	10,5	22,5			6	24565	25565	20565	21565					
6,8	11,5	23,5			6,5	24685	25685	20685	21685					
						27,94 $\pm 0,3$								

Table 14 U_R (d.c.) = 250 V; max. a.c. voltage = 160 V; Fig. 3

rated capacitance μF	T_{max}	H_{max}	L_{max}	d	P	mass g	catalogue number 2222 368					
							short leads		long leads			
							tol. $\pm 20\%$	tol. $\pm 10\%$	tol. $\pm 20\%$	tol. $\pm 10\%$		
0,027	4	12	12,5	0,6 + 0,06 - 0,05	10,16 $\pm 0,3$	0,4	44273	45273	40273	41273		
0,033							44333	45333	40333	41333		
0,039							44393	45393	40393	41393		
0,047	4,5	12,5	12,5	0,6 + 0,06 - 0,05	10,16 $\pm 0,3$	0,45	44473	45473	40473	41473		
0,056							44563	45563	40563	41563		
0,068							44683	45683	40683	41683		
0,082	5	13	12,5	0,6 + 0,06 - 0,05	10,16 $\pm 0,3$	0,5	44823	45823	40823	41823		
0,10	5	13					44104	45104	40104	41104		
0,12	5	14					17,5	0,6 + 0,06 - 0,05	10,16 $\pm 0,3$	0,65	44124	45124
0,15	5	14	15,24 $\pm 0,3$	0,7	44154	45154					40154	41154
0,18	5,5	14,5	0,8	44184	45184	40184					41184	
0,22	6	15	17,5	0,6 + 0,06 - 0,05	10,16 $\pm 0,3$	0,9	44224	45224	40224	41224		
0,27	6,5	15,5					1,1	44274	45274	40274	41274	
0,33	7	16					1,3	44334	45334	40334	41334	
0,39	5	17	26	0,8 + 0,08 - 0,05	10,16 $\pm 0,3$	1,8	44394	45394	40394	41394		
0,47	5,5	17,5					2,1	44474	45474	40474	41474	
0,56	6	18					2,5	44564	45564	40564	41564	
0,68	6,5	18,5	26	0,8 + 0,08 - 0,05	10,16 $\pm 0,3$	2,9	44684	45684	40684	41684		
0,82	7	19					3,3	44824	45824	40824	41824	
1,0	7,5	19,5					3,6	44105	45105	40105	41105	
1,2	7,5	19,5	30	0,8 + 0,08 - 0,05	10,16 $\pm 0,3$	4	44125	45125	40125	41125		
1,5	8,5	20,5					27,94 $\pm 0,3$	5,1	44155	45155	40155	41155
1,8	9,5	21,5					5,9	44185	45185	40185	41185	
2,2	10,5	22,5	30	0,8 + 0,08 - 0,05	10,16 $\pm 0,3$	6,4	44225	45225	40225	41225		

Table 15 U_R (d.c.) = 400 V; max. a.c. voltage = 220 V; Fig. 3

rated capacitance μF	T_{max}	H_{max}	L_{max}	d	P	mass g	catalogue number 2222 368																		
							short leads		long leads																
							tol. $\pm 20\%$	tol. $\pm 10\%$	tol. $\pm 20\%$	tol. $\pm 10\%$															
0,001	4	12	12,5	0,6 + 0,06 - 0,05	10,16 $\pm 0,3$	0,4	54102	55102	50102	51102															
0,0012							54122	55122	50122	51122															
0,0015							54152	55152	50152	51152															
0,0018							54182	55182	50182	51182															
0,0022							54222	55222	50222	51222															
0,0027							54272	55272	50272	51272															
0,0033							54332	55332	50332	51332															
0,0039							54392	55392	50392	51392															
0,0047							54472	55472	50472	51472															
0,0056							54562	55562	50562	51562															
0,0068							54682	55682	50682	51682															
0,0082							54822	55822	50822	51822															
0,010							54103	55103	50103	51103															
0,012							54123	55123	50123	51123															
0,015							54153	55153	50153	51153															
0,018							54183	55183	50183	51183															
0,022							54223	55223	50223	51223															
0,027							4,5	12,5	17,5	0,8 + 0,08 - 0,05	15,24 $\pm 0,3$	0,45	54273	55273	50273	51273									
0,033	5	14	17,5	0,8 + 0,08 - 0,05	15,24 $\pm 0,3$	54333	55333	50333				51333													
0,039						0,6	54393	55393				50393	51393												
0,047						0,6	54473	55473				50473	51473												
0,056						0,65	54563	55563				50563	51563												
0,068						0,7	54683	55683				50683	51683												
0,082						0,8	54823	55823				50823	51823												
0,10	5,5	14,5	26	0,8 + 0,08 - 0,05	22,86 $\pm 0,3$	0,9	54104	55104				50104	51104												
0,12	6	15				26	0,8 + 0,08 - 0,05	22,86 $\pm 0,3$				1,1	54124	55124	50124	51124									
0,15	6,5	15,5										26	0,8 + 0,08 - 0,05	22,86 $\pm 0,3$	1,3	54154	55154	50154	51154						
0,18	7	16													26	0,8 + 0,08 - 0,05	22,86 $\pm 0,3$	1,6	54184	55184	50184	51184			
0,22	5,5	17,5																26	0,8 + 0,08 - 0,05	22,86 $\pm 0,3$	1,9	54224	55224	50224	51224
0,27	6	18																			26	0,8 + 0,08 - 0,05	22,86 $\pm 0,3$	2,3	54274
0,33	6,5	18,5	30	0,8 + 0,08 - 0,05	27,94 $\pm 0,3$																			2,6	54334
0,39	7	19				30	0,8 + 0,08 - 0,05	27,94 $\pm 0,3$																3	54394
0,47	8	20										30	0,8 + 0,08 - 0,05	27,94 $\pm 0,3$										3,4	54474
0,56	8	20													30	0,8 + 0,08 - 0,05	27,94 $\pm 0,3$							3,5	54564
0,68	8,5	20,5																30	0,8 + 0,08 - 0,05	27,94 $\pm 0,3$				4	54684
0,82	9,5	21,5							30	0,8 + 0,08 - 0,05	27,94 $\pm 0,3$										4,5	54824	55824	50824	51824
1	11	23	30	0,8 + 0,08 - 0,05	27,94 $\pm 0,3$																5,0	54105	55105	50105	51105

Table 16 U_R (d.c.) = 630 V; max. a.c. voltage = 220 V; Fig. 3

rated capacitance μF	T_{max}	H_{max}	L_{max}	d	P	mass g	catalogue number 2222 368			
							short leads		long leads	
							tol. $\pm 20\%$	tol. $\pm 10\%$	tol. $\pm 20\%$	tol. $\pm 10\%$
0,01	4,5	12,5				0,45	64103	65103	60103	61103
0,012	5	13		0,6	10,16	0,5	64123	65123	60123	61123
0,015	5,5	13,5	12,5	+ 0,06	\pm	0,55	64153	65153	60153	61153
0,018	6	14		-0,05	0,3	0,6	64183	65183	60183	61183
0,022	6,5	14,5				0,7	64223	65223	60223	61223
0,027	5,5	14,5				0,9	64273	65273	60273	61273
0,033	6	15				1	64333	65333	60333	61333
0,039	6,5	15,5	17,5		15,24	1,1	64393	65393	60393	61393
0,047	7	16			\pm	1,25	64473	65473	60473	61473
0,056	7,5	16,5			0,3	1,35	64563	65563	60563	61563
0,068	8	17				1,45	64683	65683	60683	61683
0,082	5,5	17,5				1,85	64823	65823	60823	61823
0,1	6	18				2,15	64104	65104	60104	61104
0,12	7	19	26		22,86	2,5	64124	65124	60124	61124
0,15	7,5	19,5		0,8	\pm	2,9	64154	65154	60154	61154
0,18	8,5	20,5		+ 0,08	0,3	3,2	64184	65184	60184	61184
0,22	9,5	21,5		-0,05		3,5	64224	65224	60224	61224
0,27	9	21				4,3	64274	65274	60274	61274
0,33	10	22			27,94	5	64334	65334	60334	61334
0,39	11	23	30		\pm	5,65	64394	65394	60394	61394
0,47	12	24			0,3	6,5	64474	65474	60474	61474

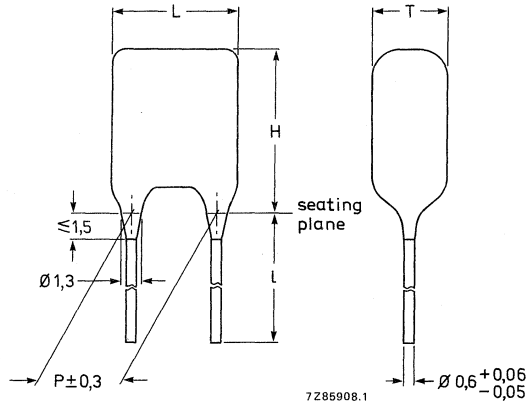

Fig. 4.

Table 17 U_R (d.c.) = 63 V; max. a.c. voltage = 40 V; Fig. 4; pitch = 5,08 mm

rated capacitance μF	T_{max}	H_{max}	L_{max}	P	mass g	catalogue number 2222 367			
						$\ell = 22 \pm 4$		$\ell = 5 \pm 1$	
						tol. $\pm 20\%$	tol. $\pm 10\%$	tol. $\pm 20\%$	tol. $\pm 10\%$
0,047	3,5	7,5	7,5	5,08 $\pm 0,3$	0,3	70473	71473	74473	75473
0,056						70563	71563	74563	75563
0,068						70683	71683	74683	75683
0,082						70823	71823	74823	75823
0,1						70104	71104	74104	75104
0,12						70124	71124	74124	75124
0,15						70154	71154	74154	75154
0,18	4	8	7,5	5,08 $\pm 0,3$	0,35	70184	71184	74184	75184
0,22	4,5	8,5			70224	71224	74224	75224	
0,27	5	9			70274	71274	74274	75274	
0,33	5,5	9,5			0,45	70334	71334	74334	75334
0,39	5,5	10,5			70394	71394	74394	75394	
0,47	6	11,5			0,5	70474	71474	74474	75474

Table 18 U_R (d.c.) = 100 V; max. a.c. voltage = 63 V; Fig. 4; pitch = 5,08 mm

rated capacitance μF	T_{max}	H_{max}	L_{max}	P	mass g	catalogue number 2222 367							
						$\varrho = 22 \pm 4$		$\varrho = 5 \pm 1$					
						tol. $\pm 20\%$	tol. $\pm 10\%$	tol. $\pm 20\%$	tol. $\pm 10\%$				
0,01	3,5	7,5	7,5	5,08 $\pm 0,3$	0,3	80103	81103	84103	85103				
0,012						80123	81123	84123	85123				
0,015						80153	81153	84153	85153				
0,018						80183	81183	84183	85183				
0,022						80223	81223	84223	85223				
0,027						80273	81273	84273	85273				
0,033					80333	81333	84333	85333					
0,039					80393	81393	84393	85393					
0,047					4	8			0,35	80473	81473	84473	85473
0,056										80563	81563	84563	85563
0,068	80683	81683	84683	85683									
0,082	4,5	8,5				80823	81823	84823	85823				
0,10					0,45	80104	81104	84104	85104				

Table 19 U_R (d.c.) = 63 V; max. a.c. voltage = 40 V; Fig. 4; pitch = 7,62 mm

rated capacitance μF	T_{max}	H_{max}	L_{max}	P	mass g	catalogue number 2222 367			
						$\varrho = 22 \pm 4$		$\varrho = 5 \pm 1$	
						tol. $\pm 20\%$	tol. $\pm 10\%$	tol. $\pm 20\%$	tol. $\pm 10\%$
0,12	4	8	10	7,62 $\pm 0,3$	0,4	10124	11124	14124	15124
0,15						10154	11154	14154	15154
0,18						10184	11184	14184	15184
0,22					10224	11224	14224	15224	
0,27					10274	11274	14274	15274	
0,33	4,5	8,5	10,5			10334	11334	14334	15334
0,39	5	9				10394	11394	14394	15394
0,47	5,5	9,5				10474	11474	14474	15474

Table 20 U_R (d.c.) = 100 V; max. a.c. voltage = 63 V; Fig. 4; pitch = 7,62 mm

rated capacitance μF	T_{max}	H_{max}	L_{max}	P	mass g	catalogue number 2222 367			
						$\varrho = 22 \pm 4$		$\varrho = 5 \pm 1$	
						tol. $\pm 20\%$	tol. $\pm 10\%$	tol. $\pm 20\%$	tol. $\pm 10\%$
0,039	4	8,5	10	7,62 $\pm 0,3$	0,4	20393	21393	24393	25393
0,047	4	8				20473	21473	24473	25473
0,056	4	8				20563	21563	24563	25563
0,068	4	8				20683	21683	24683	25683
0,082	4	8				20823	21823	24823	25823
0,10	4	8,5				20104	21104	24104	25104
0,12	4,5	9	10,5		0,5	20124	21124	24124	25124
0,15	5	9,5			0,6	20154	21154	24154	25154
0,18	5	9,5			0,6	20184	21184	24184	25184
0,22	5,5	10			0,7	20224	21224	24224	25224
0,27	6	10,5			0,7	20274	21274	24274	25274

Table 21 U_R (d.c.) = 250 V; max. a.c. voltage = 160 V; Fig. 4; pitch = 7,62 mm

rated capacitance μF	T_{max}	H_{max}	L_{max}	P	mass g	catalogue number 2222 367			
						$\varrho = 22 \pm 4$		$\varrho = 5 \pm 1$	
						tol. $\pm 20\%$	tol. $\pm 10\%$	tol. $\pm 20\%$	tol. $\pm 10\%$
0,018	4	8,5	10	7,62 $\pm 0,3$	0,4	40183	41183	44183	45183
0,022						40223	41223	44223	45223
0,027						40273	41273	44273	45273
0,033						40333	41333	44333	45333

Table 22 U_R (d.c.) = 400 V; max. a.c. voltage = 220 V; Fig. 4; pitch = 7,62 mm

rated capacitance μF	T_{max}	H_{max}	L_{max}	P	mass g	catalogue number 2222 367			
						$\varrho = 22 \pm 4$		$\varrho = 5 \pm 1$	
						tol. $\pm 20\%$	tol. $\pm 10\%$	tol. $\pm 20\%$	tol. $\pm 10\%$
0,0039	4	8,5	10	7,62 $\pm 0,3$	0,4	50392	51392	54392	55392
0,0047						50472	51472	54472	55472
0,0056						50562	51562	54562	55562
0,0068						50682	51682	54682	55682
0,0082						50822	51822	54822	55822
0,010						50103	51103	54103	55103
0,012						50123	51123	54123	55123
0,015						50153	51153	54153	55153

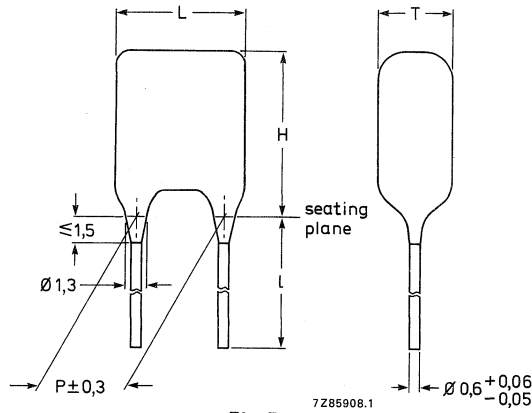

Fig. 5.

Table 23 U_R (d.c.) = 100 V; max. a.c. voltage = 63 V, Fig. 5

rated capacitance μF	T_{max}	H_{max}	L_{max}	d	P	mass g	catalogue number 2222 369						
							short leads 5 ± 1		long leads 22 ± 4				
							tol. ± 20%	tol. ± 10%	tol. ± 20%	tol. ± 10%			
0,056	4	9,5	12,5	0,6 + 0,06 - 0,05	10,16 ± 0,3	0,4	24563	25563	20563	21563			
0,068							24683	25683	20683	21683			
0,082							24823	25823	20823	21823			
0,10						4,5	10	12,5	0,45	24104	25104	20104	21104
0,12										24124	25124	20124	21124
0,15										24154	25154	20154	21154
0,18	5	10,5	12,5	0,5	24184	25184	20184	21184					
0,22					24224	25224	20224	21224					

Table 24 U_R (d.c.) = 250 V; max. a.c. voltage = 160 V; Fig. 5

rated capacitance μF	T_{max}	H_{max}	L_{max}	d	P	mass g	catalogue number 2222 369			
							short leads 5 ± 1		long leads 22 ± 4	
							tol. ± 20%	tol. ± 10%	tol. ± 20%	tol. ± 10%
0,027	4	9,5	12,5	0,6 + 0,06 - 0,05	10,16 ± 0,3	0,4	44273	45273	40273	41273
0,033							44333	45333	40333	41333
0,039							44393	45393	40393	41393
0,047							44473	45473	40473	42473
0,056	4,5	10	12,5	0,45	0,5	44563	45563	40563	41563	
0,068						44683	45683	40683	41683	
0,082	5	10,5	12,5	0,5	44823	45823	40823	41823		
0,10					44104	45104	40104	41104		

Table 25 U_R (d.c.) = 400 V; max. a.c. voltage = 220 V; Fig. 5

rated capacitance μF	T_{max}	H_{max}	L_{max}	d	P	mass g	catalogue number 2222 369			
							short leads 5 ± 1		long leads 22 ± 4	
							tol. $\pm 20\%$	tol. $\pm 10\%$	tol. $\pm 20\%$	tol. $\pm 10\%$
0,001	4	9,5	12,5	0,6 +0,06 -0,05	10,16 $\pm 0,3$	0,4	54102	55102	50102	51102
0,0012							54122	55122	50122	51122
0,0015							54152	55152	50152	51152
0,0018							54182	55182	50182	51182
0,0022							54222	55222	50222	51222
0,0027							54272	55272	50272	51272
0,0033							54332	55332	50332	51332
0,0039							54392	55392	50392	51392
0,0047							54472	55472	50472	51472
0,0056							54562	55562	50562	51562
0,0068							54682	55682	50682	51682
0,0082							54822	55822	50822	51822
0,010							54103	55103	50103	51103
0,012							54123	55123	50123	51123
0,015							54153	55153	50153	55153
0,018							54183	55183	50183	51183
0,022							54223	55223	50223	51223
0,027	4,5	10	12,5			0,45	54273	55273	50273	51273
0,033	4,5	10	12,5			0,45	54333	55333	50333	51333

Table 26 U_R (d.c.) = 630 V; max. a.c. voltage = 220 V; Fig. 5

rated capacitance μF	T_{max}	H_{max}	L_{max}	d	P	mass g	catalogue number 2222 369					
							short leads 5 ± 1		long leads 22 ± 4			
							tol. $\pm 20\%$	tol. $\pm 10\%$	tol. $\pm 20\%$	tol. $\pm 10\%$		
0,010	4,5	10	12,5	0,6 +0,06 -0,05	10,16 $\pm 0,3$	0,45	64103	65103	60103	61103		
0,012	5	10,5	12,5			0,5	64123	65123	60123	61123		
0,015	5,5	11	12,5			0,55	64153	65153	60153	61153		
0,018	6	11,5	12,5			0,6	64183	65183	60183	61183		
0,022	6,5	12	12,5					0,7	64223	65223	60223	61223

Marking

- a. Rated capacitance
- b. Rated voltage
- c. Tolerance on rated capacitance
- d. Category voltage
- e. Year and month of manufacture
- f. Manufacturer's name
- g. Climatic category
- h. Manufacturer's type designation

● Styles 2222 365, 2222 366, and 2222 367:

- The capacitors with a pitch of 5,08 mm are marked in black ink on the top with a, b and c as follows:

1st line: rated capacitance in μF without unit symbol;

2nd line: tolerance code (M = $\pm 20\%$, K = $\pm 10\%$, J = $\pm 5\%$),
rated d.c. voltage without unit symbol.

example: 0.047
K 63

- The capacitors with a pitch of 5,08 (7,62) mm or 7,62 mm are marked in black ink on the top with a, b and c as follows:

1st line: rated capacitance in pF or μF without unit symbol,
tolerance code (M = $\pm 20\%$, K = $\pm 10\%$, J = $\pm 5\%$);

2nd line: rated d.c. voltage without unit symbol,
code for dielectric material (MKT)

example: 0,047 K
100 MKT

● Styles 2222 368 and 2222 369:

- The capacitors are marked in black ink on top with a, b, c, f and h as follows:

1st line: rated capacitance in pF or μF ,
tolerance ($\pm 20\%$ identified by M or 20%, $\pm 10\%$ by
K or 10% and $\pm 5\%$ by J or 5%);

2nd line: rated d.c. voltage,
code for dielectric material (MKT).

The manufacturer's name is indicated at the left.

Code for factory of origin is indicated at the right.

The package containing the capacitors is marked with a to h.

2222 365 2222 366
2222 367 2222 368
2222 369

Mounting

The capacitors are for printed-wiring applications.

Capacitors of style 2222 365 (supplied on tape on reel or in ammunition packing) are suitable for mounting on printed-wiring boards by means of automatic insertion machines.

Ratings and characteristics

Unless otherwise specified all electrical values apply to an ambient free air temperature of $23 \pm 1 \text{ }^\circ\text{C}$, an atmospheric pressure of 86 to 106 kPa and a relative humidity of $50 \pm 2\%$.

Capacitance

Rated capacitance range at 1 kHz see Tables 1 to 26

Tolerance on rated capacitance see Tables 1 to 26

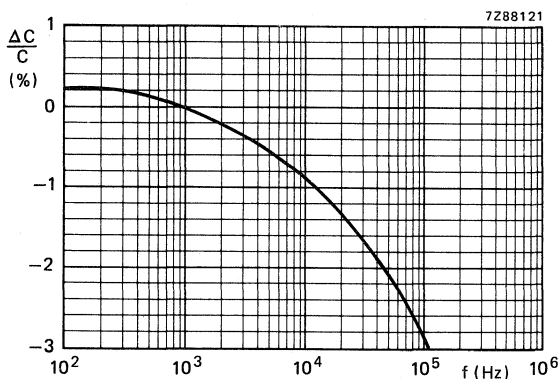

Fig. 6 Capacitance as a function of frequency; typical curve.

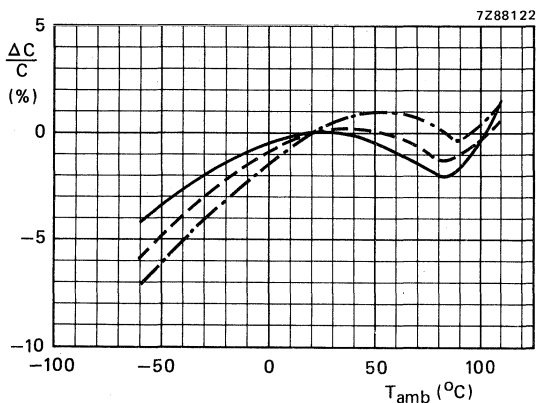

Fig. 7 Capacitance as a function of ambient free air temperature; typical curves.

- for all capacitance values, measured at 1 kHz, 1 V.
- - - for capacitance values $\leq 1 \mu\text{F}$, measured at 10 kHz, 1 V.
- · - · for capacitance values $\leq 0,1 \mu\text{F}$, measured at 100 kHz, 0,3 V.

Voltage

Rated voltage U_R (d.c.)	See Tables 1 to 26
Category voltage U_C	$0,8 \times U_R$ (d.c.)
Maximum a.c. voltage (r.m.s. value), at 50 to 60 Hz	see Tables 1 to 26
Test voltage	
between terminations	$1,6 \times U_R$ (d.c.)
between interconnected terminations and case	$2 \times U_R$ (d.c.); min. 200 V

Temperature

Climatic category	40/100/56
Rated temperature	85 °C
Storage temperature range	-40 to + 100 °C

Notes:

- The sum of the d.c. voltage and the peak value of the superimposed a.c. voltage must be $\leq U_R$ (d.c.).
- For waveforms other than sinusoidal the maximum permissible dissipation must not be exceeded.

Maximum pulse load

rated voltage V	maximum pulse load V/ μ s					
	L = 7,5 mm	L = 10 mm	L = 12,5 mm	L = 17,5 mm	L = 26 mm	L = 30 mm
63	55	17				
100	90	30	24	10	4	3,5
250		60	35	14	6	5
400		95	55	22	10	8
630			80	35	14	12

The maximum pulse load values in the table are valid for pulse voltages equal to the rated voltage.
 For lower pulse voltages the given values may be multiplied by U_R /applied voltage.

Note:

If the pulse load requirement is satisfied, a check must be made to ascertain that the maximum dissipation is not exceeded.

Tangent of loss angle

capacitance	frequency		
	1 kHz	10 kHz	100 kHz
$C \leq 0,1 \mu\text{F}$	$\leq 75 \times 10^{-4}$	$\leq 130 \times 10^{-4}$	$\leq 225 \times 10^{-4}$
$0,1 \mu\text{F} < C \leq 0,47 \mu\text{F}$	$\leq 75 \times 10^{-4}$	$\leq 130 \times 10^{-4}$	$\leq 300 \times 10^{-4}$
$0,47 \mu\text{F} < C \leq 1 \mu\text{F}$	$\leq 75 \times 10^{-4}$	$\leq 130 \times 10^{-4}$	
$C > 1 \mu\text{F}$	$\leq 75 \times 10^{-4}$	$\leq 130 \times 10^{-4}$	

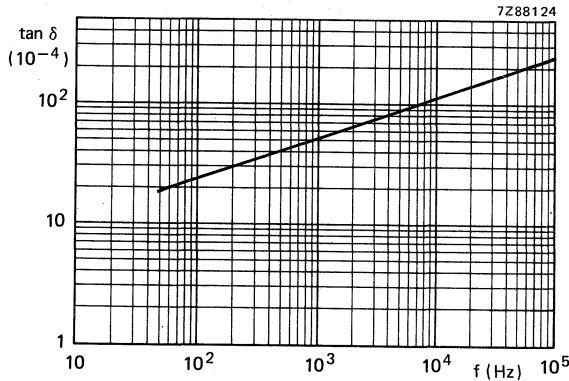

Fig. 8 Tan δ as a function of frequency, typical curve.

Insulation resistance

The insulation resistance is measured after a voltage has been applied for 1 min \pm 5 s, the voltage being 10 \pm 1 V for the 63 V version, 100 \pm 15 V for the 100 V, 250 V and 400 V versions and 500 \pm 50 V for the 630 V version at $T_{amb} = 20 \text{ }^\circ\text{C}$.

R between terminations, for $C_R \leq 0,33 \mu\text{F}$

- 63 V and 100 V versions > 15 000 M Ω
- 250 V, 400 V and 630 V versions > 30 000 M Ω

RC between terminations, for $C_R > 0,33 \mu\text{F}$

- 63 V and 100 V versions > 5000 s
- 250 V, 400 V and 630 V versions > 10 000 s

R between interconnected terminations and case (foil method) > 30 000 M Ω

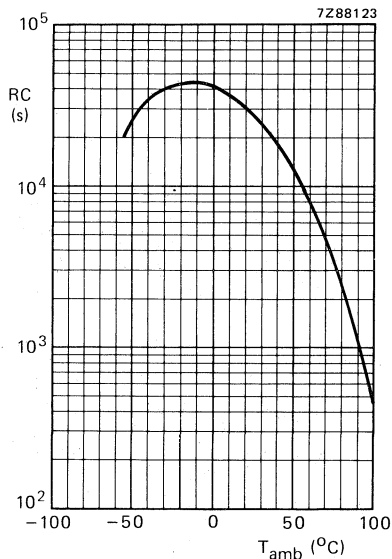

Fig. 9 RC-product as a function of ambient free air temperature; typical curve.

Maximum dissipation

Notes

In applications where voltages higher than 50 V are applied, it is recommended that the power in the capacitor be limited to 2,5 VA in case of capacitor failure.

If the requirement for the maximum permissible power dissipation is satisfied, a check must be made to ascertain that the maximum permissible pulse load is not exceeded.

The maximum a.c. voltage has been specified for 50 to 60 Hz and at 23 °C. This voltage value must also never be exceeded at other frequencies. This permissible a.c. voltage may further be limited by the following requirements:

1. The power dissipation must not exceed the specified limit P_{max} .
2. The steepness of the a.c. voltage must not exceed the specified limit.

The power dissipated by a capacitor is a function of the voltage across the series resistance (R_s) or of the current through the series resistance and is expressed by

$$P = \frac{V_{R_s}^2}{R_s} = I^2 R_s \tag{1}$$

$$V_{R_3}^2 = \frac{R_s^2}{R_s^2 + 1/\omega^2 C^2} V_{ac}^2 \tag{2a}$$

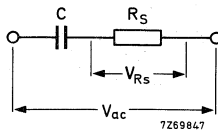

Because for these capacitors $\tan d = R_s \omega C = < 0,1$, the formula (2a) can be simplified to

$$V_{R_s}^2 = \frac{R_s^2}{1/\omega^2 C^2} V_{ac}^2 = R_s^2 \omega^2 C^2 V_{ac}^2 \tag{2b}$$

Thus $P = R_s \omega^2 C^2 V_{ac}^2 \tag{3a}$

or $P = (R_s C) C \omega^2 V_{ac}^2 \tag{3b}$

The term $R_s C$ can be found from Fig. 10, C (in farads), $\omega = 2\pi f$ and V_{ac} are assumed to be known.

The maximum permissible value of power dissipation (P_{max}), which depends on the dimensions of the capacitor and on the ambient free air temperature, can be read from Figs 11 and 12.

Thus, when the actual power has been calculated with equation (3b), Figs 11 and 12 give the minimum size of capacitor which can dissipate this power.

Example of using Figs 10, 11 and 12

A capacitor of $0,1 \mu F$ should be used at an a.c. voltage of 10 V, a frequency of 10 kHz and an ambient temperature of $50^\circ C$.

The $R_s C$ -product is $2 \times 10^{-7} \Omega F$ (from Fig. 10), so that the power to be dissipated is

$$\begin{aligned} P &= (R_s C) C \omega^2 V_{ac}^2 \\ &= 2 \cdot 10^{-7} \times 0,1 \cdot 10^{-6} \times (2\pi)^2 \times 10^8 \times 10^2 W \\ &= 7,8 mW \end{aligned}$$

For a rated voltage of 10 Vac a capacitor of the 63 V range is required at least.

Capacitor $0,1 \mu F/63 Vac$ is satisfactory because of its dimensions $3,5 mm \times 12,5 mm \times 7,5 mm$ and its dissipated power of 70 mW at $50^\circ C$.

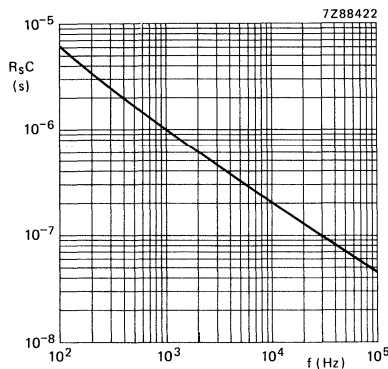

Fig. 10 Maximum product of series resistance and capacitance as a function of frequency.

curve	dimensions (mm)	
	T_{max}	L_{max}
1	3,5	7,5
2	4	7,5
3	4,5	7,5
4	5	7,5
5	5,5	7,5
6	6	7,5
7	4	10
8	4,5	10,5
9	5	10,5
10	5,5	10,5
11	6	10,5

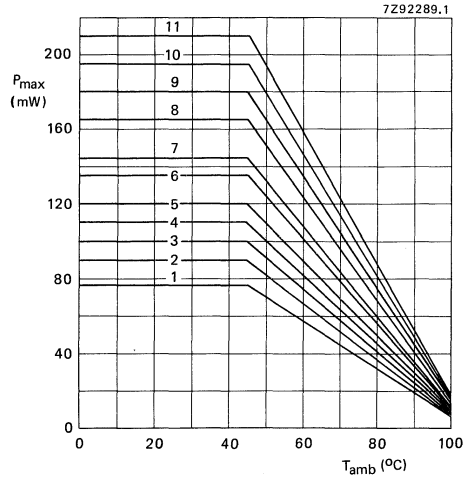

Fig. 11 Maximum dissipation as a function of ambient free air temperature, styles 2222 365, 2222 366 and 2222 367.

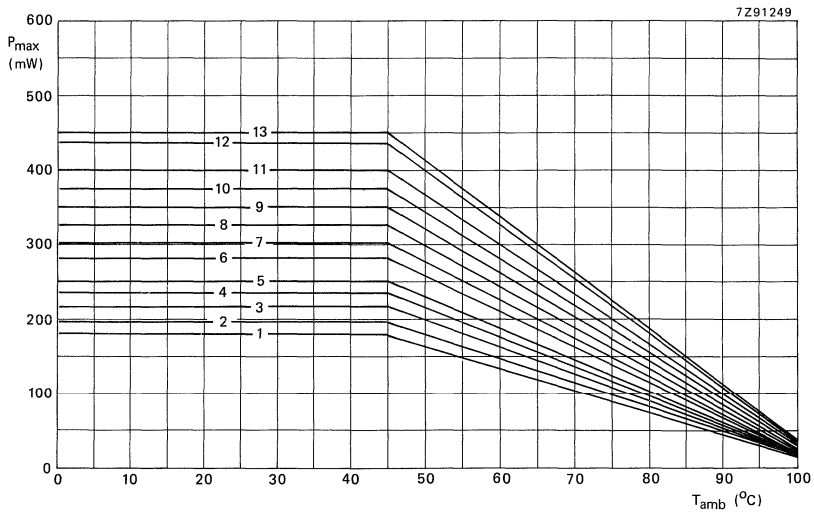

Fig. 12a Maximum dissipation as a function of ambient free air temperature; styles 2222 368 and 2222 369.

curve	dimensions (mm)	
	T _{max}	L _{max}
1	4	12,5
2	4,5	12,5
3	5	12,5
4	5,5	12,5
5	6	12,5
6	6,5	12,5
7	5	17,5
8	5,5	17,5
9	6	17,5
10	6,5	17,5
11	7	17,5
12	7,5	17,5
13	8	17,5
14	8,5	17,5
15	5	26
16	5,5	26
17	6	26
18	6,5	26
19	7	26
20	7,5	26
21	8	26
22	8,5	26
23	7,5	30
24	8	30
25	8,5	30
26	9	30
27	9,5	30
28	10	30
29	10,5	30
30	11	30
31	11,5	30
32	12	30
33	13	30

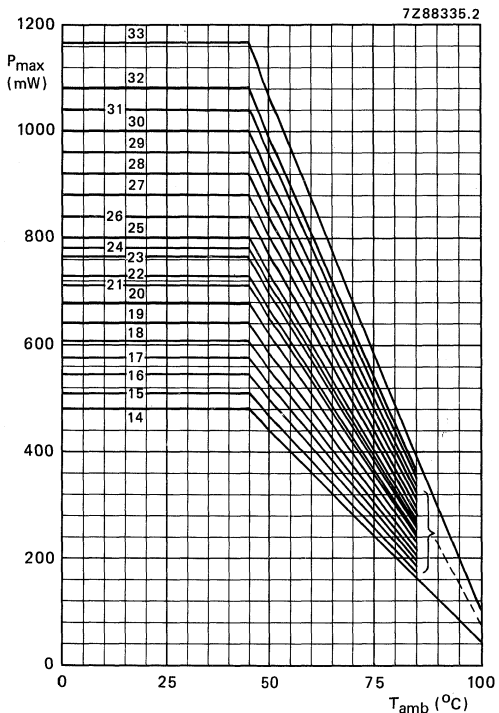

Fig. 12b Maximum dissipation as a function of ambient free air temperature; styles 2222 368 and 2222 369.

PACKING

Styles 2222 366, 2222 367, 2222 368 and 2222 369

The capacitors are supplied in boxes; the number per box is given in the table below.

L _{max} mm	T _{max} mm	number of capacitors per box	
		short leads	long leads
7,5 10		1000	1000
12,5 17,5		2000	1000
26	≤ 7	1000	1000
	≥ 7,5	1000	500
30		500	500

Style 2222 365

The capacitors are supplied on tape on reel and in ammunition packing.

The number of capacitors per reel and per pack is given in the table below.

T _{max} mm	number of capacitors per reel or per ammunition packing
4	1500
≥ 4,5	1000

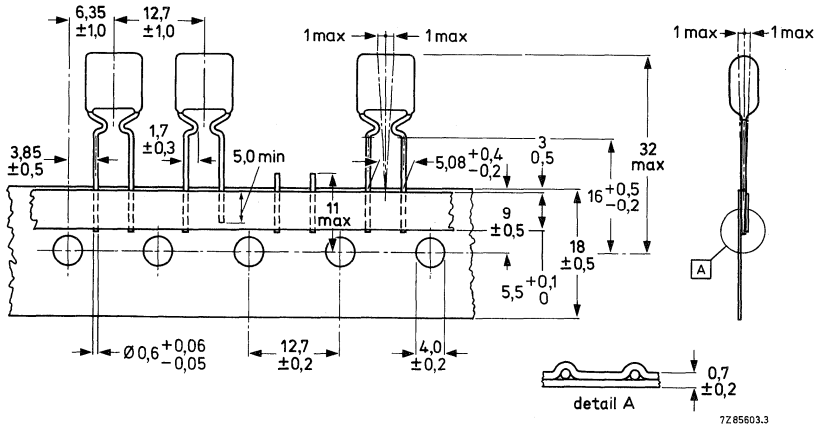

Fig. 13 Capacitors on tape.

Cumulative pitch error: 1,0 mm/20 pitches.

Maximum 0,5% of the total number of capacitors per reel may be missing, but no more than 2 consecutive positions may be vacant.

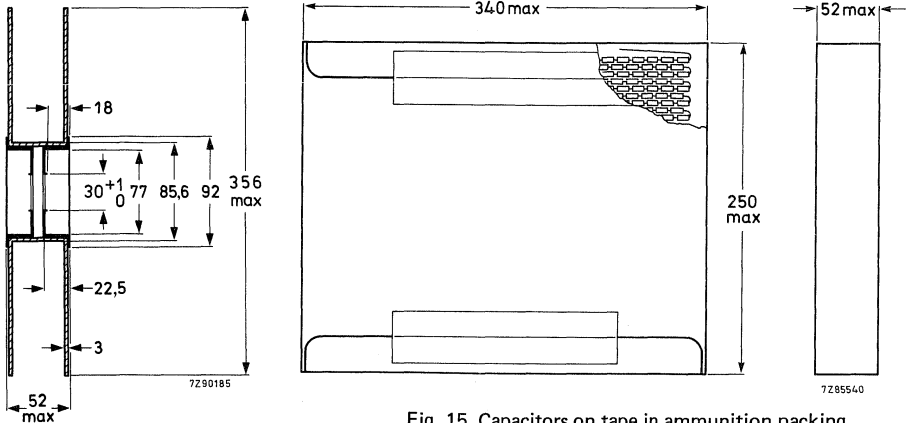

Fig. 14 Reel.

Fig. 15 Capacitors on tape in ammunition packing.

2222 365 2222 366
2222 367 2222 368
2222 369

Characteristics concerning taped capacitors:

Pull-out force of the component ≥ 5 N
Pull-off force of adhesive tape ≥ 6 N
Tearing force of tape ≥ 15 N

Storage conditions:

Storage temperature range -25 to $+40$ °C
Relative humidity $\leq 80\%$

INSPECTION REQUIREMENTS

metallized polyethyleneterephthalate film capacitors (MKT)

Note 1

Sub-clause numbers of tests and performance requirements refer to the Sectional Specification, IEC-publication 384-2 and GENERAL DATA of specifications.

Note 2

In this table: D = destructive, ND = non-destructive.

Note 3

For the type ranges with CECC Qualification Approval separate periodic C-tests are carried out as prescribed by the CECC Detail specification.

clause number and test (see Note 1)	D or ND	conditions of test (see Note 1)	performance requirements 2222 341
Group A Inspection (lot-by-lot)			
Sub-group A1	ND		
4.1 Visual examination			<ul style="list-style-type: none"> – No mechanical failures. – Legible marking and as specified in GENERAL DATA of this specification.
4.2 Dimensions		Gauging	<ul style="list-style-type: none"> – As specified in Tables in GENERAL DATA.
Sub-group A2			
4.2.1 Voltage proof (Test A)		at $1,6 \times U_R$ (d.c.) for 1 s	<ul style="list-style-type: none"> – No breakdown or flashover.
4.2.2 Capacitance		at 1 kHz	<ul style="list-style-type: none"> – Within specified tolerance.
4.2.3 Tangent of loss angle		Styles 2222 365 to 371: for $C_R \leq 470$ nF at 100 kHz; for $C_R > 470$ nF at 10 kHz. Styles 2222 341 and 344: at 10 kHz.	<ul style="list-style-type: none"> – As in GENERAL DATA of this specification.
4.2.4 Insulation resistance (Test A)		at 10 V for $U_R = 63$ V, at 100 V for $U_R = 100$ V, 250 V, 400 V, at 500 V for $U_R = 630$ V.	<ul style="list-style-type: none"> – As in GENERAL DATA of this specification.

performance requirements
2222 344-370-371

performance requirements
2222 365 to 369

- No mechanical failures.
- Legible marking and as specified in GENERAL DATA of this specification.
- As specified in Tables in GENERAL DATA.

- No breakdown or flashover.

- Within specified tolerance.
- As in GENERAL DATA of this specification.

- As in GENERAL DATA of this specification.

- No mechanical failures.
- Legible marking and as specified in GENERAL DATA of this specification.
- As specified in Tables in GENERAL DATA.

- No breakdown or flashover.

- Within specified tolerance.
- As in GENERAL DATA of this specification.

- As in GENERAL DATA of this specification.

sub-clause number and test (see Note 1)	D or ND	conditions of test (see Note 1)	performance requirements 2222 341
Group B Inspection Lot-by-lot for CECC assessed types (For the other types periodic tests) 4.5 Solderability	D	Without ageing Method: 1 Solder bath: 235 °C	Good tinning as evidenced by free flowing of the solder with wetting of the terminations.
Group C Inspection (periodic) Sub-group CIA Part of sample of Sub-group C1 4.1 Dimensions (detail) 4.3.1 Initial measurements 4.3 Robustness of terminations 4.4 Resistance to soldering heat 4.4.2 Final measurements	D	Capacitance Tangent of loss angle for $C_R \leq 470 \text{ nF}$ at 100 kHz, $C_R > 470 \text{ nF}$ at 10 kHz Tensile, bending and torsion Method: 1A Solder bath: 260 °C Duration: 10 s Visual examination Capacitance Tangent of loss angle	As specified in Tables in GENERAL DATA No visible damage. No visible damage. Legible marking. $\Delta C/C \leq 2\%$ of the value measured initially. Increase of $\tan \delta$ $\leq 0,005$ for $C_R \leq 100 \text{ nF}$, $\leq 0,01$ for $C_R > 100 \text{ nF}$ and $\leq 220 \text{ nF}$, $\leq 0,015$ for $C_R > 220 \text{ nF}$ and $\leq 470 \text{ nF}$, $\leq 0,003$ for $C_R > 470 \text{ nF}$, compared to values measured in 4.3.1.

performance requirements 2222 344-370-371	performance requirements 2222 365 to 369
<p>Good tinning as evidenced by free flowing of the solder with wetting of the terminations.</p>	<p>Good tinning as evidenced by free flowing of the solder with wetting of the terminations.</p>
<p>As specified in Tables in GENERAL DATA</p>	<p>As specified in Tables in GENERAL DATA</p>
<p>No visible damage.</p>	<p>No visible damage.</p>
<p>No visible damage. Legible marking. $\Delta C/C \leq 1\%$ of the value measured initially. Increase of $\tan \delta$ $\leq 0,005$ for $C_R \leq 100$ nF, $\leq 0,01$ for $C_R > 100$ nF and ≤ 220 nF, $\leq 0,015$ for $C_R > 220$ nF and ≤ 470 nF, $\leq 0,003$ for $C_R > 470$ nF, compared to values measured in 4.3.1.</p>	<p>No visible damage. Legible marking. $\Delta C/C \leq 2\%$ of the value measured initially. Increase of $\tan \delta$ $\leq 0,005$ for $C_R \leq 100$ nF, $\leq 0,01$ for $C_R > 100$ nF and ≤ 220 nF, $\leq 0,015$ for $C_R > 220$ nF and ≤ 470 nF, $\leq 0,003$ for $C_R > 470$ nF, compared to values measured in 4.3.1.</p>

sub-clause number and test (see Note 1)	D or ND	conditions of test (see Note 1)	performance requirements 2222 341
Sub-group C1B Other part of sample of Sub-group C1 4.6.1 Initial measurements	D	Capacitance Tangent of loss angle for $C_R \leq 470 \text{ nF}$ at 100 kHz, $C_R > 470 \text{ nF}$ at 10 kHz	
4.6 Rapid change of temperature		θ A = lower cat. temp. θ B = upper cat. temp. 5 cycles, duration $t = 30 \text{ min.}$ Visual examination	No visible damage.
4.7 Vibration		Method of mounting see Note below. Procedure B4. Frequency range: 10 to 55 Hz Amplitude: 0,75 mm or acceleration: 98 m/s ² (whichever is the less severe). Total duration: 6 h	
4.7.2 Final inspection		Visual examination	No visible damage.
4.9 Shock		Method of mounting see Note below. Pulse shape: half sine Acceleration: 490 m/s ² Duration of pulse: 11 ms	
4.9.3 Final measurements		Visual examination Capacitance Tangent of loss angle Insulation resistance	No visible damage. $\Delta C/C \leq 3\%$ of the value measured in 4.6.1. Increase of $\tan \delta$ $\leq 0,005$ for $C_R \leq 100 \text{ nF}$, $\leq 0,01$ for $C_R > 100 \text{ nF}$ and $\leq 220 \text{ nF}$, $\leq 0,015$ for $C_R > 220 \text{ nF}$ and $\leq 470 \text{ nF}$, $\leq 0,003$ for $C_R > 470 \text{ nF}$ compared to values measured in 4.6.1. As in GENERAL DATA of this specification.

Note

The capacitor shall be mechanically fixed by the leads and the body (stand-off pips or ridges) shall be in good contact with the printed-wiring board, also the body of capacitors with a mass > 6 g shall be clamped to the printed-wiring board.

performance requirements 2222 344-370-371	performance requirements 2222 365 to 369
<p>No visible damage.</p>	<p>No visible damage.</p>
<p>No visible damage.</p>	<p>No visible damage.</p>
<p>No visible damage. $\Delta C/C \leq 3\%$ of the value measured in 4.6.1. Increase of $\tan \delta \leq 0,005$ ($\leq 0,01$ for 2222 370 and 371) for $C_R \leq 100$ nF, $\leq 0,01$ for $C_R > 100$ nF and ≤ 220 nF, $\leq 0,015$ for $C_R > 220$ nF and ≤ 470 nF, $\leq 0,003$ for $C_R > 470$ nF compared to values measured in 4.6.1 As in GENERAL DATA of this specification.</p>	<p>No visible damage. $\Delta C/C \leq 3\%$ of the value measured in 4.6.1. Increase of $\tan \delta$ $\leq 0,005$ for $C_R \leq 100$ nF, $\leq 0,01$ for $C_R > 100$ nF and ≤ 220 nF, $\leq 0,015$ for $C_R > 220$ nF and ≤ 470 nF, $\leq 0,003$ for $C_R > 470$ nF compared to values measured in 4.6.1. As in GENERAL DATA of this specification.</p>

sub-clause number and test (see Note 1)	D or ND	conditions of test (see Note 1)	performance requirements 2222 341
<p>Sub-group C1</p> <p>Combined sample of specimens of Sub-groups C1A and C1B</p> <p>4.10 Climatic sequence</p> <p>4.10.2 Dry heat</p> <p>4.10.3 Damp heat cyclic, Test Db, first cycle</p> <p>4.10.4 Cold</p> <p>4.10.6 Damp heat cyclic, Test Db, remaining cycles</p> <p>4.10.6.2 Final measurements</p>	D	<p>Temperature: upper category temperature Duration: 16 h</p> <p>Temperature: lower category temperature Duration: 2 h</p> <p>Visual examination</p> <p>Capacitance</p> <p>Tangent of loss angle</p> <p>Insulation resistance</p>	<p>No visible damage.</p> <p>Legible marking.</p> <p>$\Delta C/C \leq 3\%$ of value measured in 4.4.2 or 4.9.3.</p> <p>Increase of $\tan \delta$</p> <p>$\leq 0,007$ for $C_R \leq 100$ nF, $\leq 0,01$ for $C_R > 100$ nF and ≤ 220 nF, $\leq 0,015$ for $C_R > 220$ nF and ≤ 470 nF, $\leq 0,005$ for $C_R > 470$ nF compared to values measured in 4.3.1 or 4.6.1.</p> <p>$\geq 50\%$ of values in GENERAL DATA of this specification.</p>

performance requirements
2222 344-370-371

performance requirements
2222 365 to 369

No visible damage.
Legible marking.
 $\Delta C/C \leq 5\%$ of value
measured in 4.4.2 or 4.9.3.
Increase of $\tan \delta \leq 0,007$
($\leq 0,01$ for 2222 370 and 371)
for $C_R \leq 100$ nF,
 $\leq 0,01$ for $C_R > 100$ nF and
 ≤ 220 nF,
 $\leq 0,015$ for $C_R > 220$ nF and
 ≤ 470 nF,
 $\leq 0,005$ for $C_R > 470$ nF
compared to values
measured in 4.3.1 or 4.6.1.
 $\geq 50\%$ of values in GENERAL
DATA of this specification.

No visible damage.
Legible marking.
 $\Delta C/C \leq 5\%$ of value
measured in 4.4.2 or 4.9.3.
Increase of $\tan \delta$
 $\leq 0,007$ for $C_R \leq 100$ nF,
 $\leq 0,01$ for $C_R > 100$ nF and
 ≤ 220 nF,
 $\leq 0,015$ for $C_R > 220$ nF and
 ≤ 470 nF,
 $\leq 0,005$ for $C_R > 470$ nF
compared to values
measured in 4.3.1 or 4.6.1.
 $\geq 50\%$ of values in GENERAL
DATA of this specification.

sub-clause number and test (see Note 1)	D or ND	conditions of test (see Note 1)	performance requirements 2222 341
Sub-group C2 4.11 Damp heat steady state 4.11.1 Initial measurements 4.11.3 Final measurements	D	Capacitance Tangent of loss angle for $C_R \leq 470 \text{ nF}$ at 100 kHz, $C_R > 470 \text{ nF}$ at 10 kHz Visual examination Capacitance Tangent of loss angle Insulation resistance	No visible damage. Legible marking. $\Delta C/C \leq 3\%$ of the value measured in 4.11.1. Increase of $\tan \delta$ $\leq 0,007$ for $C_R \leq 100 \text{ nF}$, $\leq 0,01$ for $C_R > 100 \text{ nF}$ and $\leq 220 \text{ nF}$, $\leq 0,015$ for $C_R > 220 \text{ nF}$ and $\leq 470 \text{ nF}$, $\leq 0,005$ for $C_R > 470 \text{ nF}$ compared to values measured in 4.11.1. $\geq 50\%$ of values in GENERAL DATA of this specification.
Sub-group C3 4.12 Endurance 4.12.1 Initial measurements	D	Duration: 2000 h; $1,25 U_R$ (d.c.) at 85 °C, $1,25 U_C$ at 100 °C Capacitance Tangent of loss angle for $C_R \leq 470 \text{ nF}$ at 100 kHz, $C_R > 470 \text{ nF}$ at 10 kHz	

performance requirements 2222 344-370-371	performance requirements 2222 365 to 369
<p>No visible damage. Legible marking $\Delta C/C \leq 3\%$ ($\leq 5\%$ for 2222 370) of the value measured in 4.11.1. Increase of $\tan \delta$ $\leq 0,007$ for $C_R \leq 100$ nF, $\leq 0,01$ for $C_R > 100$ nF and ≤ 220 nF, $\leq 0,015$ for $C_R > 220$ nF and ≤ 470 nF, $\leq 0,005$ for $C_R > 470$ nF compared to values measured in 4.11.1. $\geq 50\%$ of values in GENERAL DATA of this specification.</p>	<p>No visible damage. Legible marking. $\Delta C/C \leq 5\%$ of the value measured in 4.11.1. Increase of $\tan \delta$ $\leq 0,007$ for $C_R \leq 100$ nF, $\leq 0,01$ for $C_R > 100$ nF and ≤ 220 nF, $\leq 0,015$ for $C_R > 220$ nF and ≤ 470 nF, $\leq 0,005$ for $C_R > 470$ nF compared to values measured in 4.11.1. $\geq 50\%$ of values in GENERAL DATA of this specification.</p>

sub-clause number and test (see Note 1)	D or ND	conditions of test (see Note 1)	performance requirements 2222 341
4.12.5 Final measurements		Visual examination Capacitance Tangent of loss angle Insulation resistance	No visible damage. Legible marking. $\Delta C/C < 5\%$ of value measured in 4.12.1.* Increase of $\tan \delta$ $\leq 0,005$ for $C_R \leq 100$ nF, $\leq 0,01$ for $C_R > 100$ nF and ≤ 220 nF, $\leq 0,015$ for $C_R > 220$ nF and ≤ 470 nF, $\leq 0,003$ for $C_R > 470$ nF compared to values measured in 4.12.1. $\geq 50\%$ of values in GENERAL DATA of this specification.
Sub-group C4 4.13 Charge and discharge 4.13.1 Initial measurements 4.13.3 Final measurements	D	10 000 cycles (50 c/s) charge to U_R half sine wave Duration: 5 ms, discharge $R =$ $\frac{U_R}{C_R \cdot 5 \left(\frac{dU}{dt}\right) R}$ with a min. of 2,2 Ω Capacitance Tangent of loss angle for $C_R \leq 470$ nF at 100 kHz, $C_R > 470$ nF at 10 kHz Capacitance Tangent of loss angle Insulation resistance	$\Delta C/C \leq 3\%$ of value measured in 4.13.1. Increase of $\tan \delta$ $\leq 0,005$ for $C_R \leq 100$ nF, $\leq 0,01$ for $C_R > 100$ nF and ≤ 220 nF, $\leq 0,015$ for $C_R > 220$ nF and ≤ 470 nF, $\leq 0,003$ for $C_R > 470$ nF. $\geq 50\%$ of values in GENERAL DATA of this specification.

* $\Delta C/C \leq 8\%$ for dimensions 5,1 mm x 8,8 mm x 14,6 mm.

performance requirements 2222 344-370-371	performance requirements 2222 365 to 369
<p>No visible damage. Legible marking. $\Delta C/C < 3\%$ of value measured in 4.12.1. Increase of $\tan \delta \leq 0,005$ ($\leq 0,01$ at $100\text{ }^\circ\text{C}$ and $\leq 0,005$ at $85\text{ }^\circ\text{C}$ for 2222 370 and 371) for $C_R < 100\text{ nF}$, $\leq 0,01$ for $C_R > 100\text{ nF}$ and $\leq 220\text{ nF}$, $\leq 0,015$ for $C_R \geq 220\text{ nF}$ and $\leq 470\text{ nF}$, $\leq 0,003$ for $C_R > 470\text{ nF}$, compared to values measured in 4.12.1. $\geq 50\%$ of values in GENERAL DATA of this specification.</p>	<p>No visible damage. Legible marking. $\Delta C/C < 5\%$ of value measured in 4.12.1. Increase of $\tan \delta$ $\leq 0,005$ for $C_R \leq 100\text{ nF}$, $\leq 0,01$ for $C_R > 100\text{ nF}$ and $\leq 220\text{ nF}$, $\leq 0,015$ for $C_R > 220\text{ nF}$ and $\leq 470\text{ nF}$, $\leq 0,003$ for $C_R > 470\text{ nF}$ compared to values measured in 4.12.1. $\geq 50\%$ of values in GENERAL DATA of this specification.</p>
<p>$\Delta C/C \leq 3\%$ of value measured in 4.13.1. Increase of $\tan \delta \leq 0,005$ for $C_R \leq 100\text{ nF}$, $\leq 0,01$ for $C_R > 100\text{ nF}$ and $\leq 220\text{ nF}$, $\leq 0,015$ for $C_R > 220\text{ nF}$ and $\leq 470\text{ nF}$, $\leq 0,003$ for $C_R > 470\text{ nF}$. $\geq 50\%$ of values in GENERAL DATA of this specification.</p>	<p>$\Delta C/C \leq 3\%$ of value measured in 4.13.1. Increase of $\tan \delta$ $\leq 0,005$ for $C_R \leq 100\text{ nF}$, $\leq 0,01$ for $C_R > 100\text{ nF}$ and $\leq 220\text{ nF}$, $\leq 0,015$ for $C_R > 220\text{ nF}$ and $\leq 470\text{ nF}$, $\leq 0,003$ for $C_R > 470\text{ nF}$. $\geq 50\%$ of values in GENERAL DATA of this specification.</p>

additional tests	D or ND	conditions of test	performance requirements 2222 341
<p>Sub-group ADD1</p> <p>A.1 Heat storage</p> <p>A.1.1 Initial measurements</p> <p>A.1.2 Final measurements</p>	D	<p>Duration: 2000 h Temperature: upper category temperature</p> <p>Capacitance Tangent of loss angle for $C_R \leq 470$ nF at 100 kHz, $C_R > 470$ nF at 10 kHz</p> <p>Capacitance Tangent of loss angle</p> <p>Insulation resistance</p>	<p>$\Delta C/C \leq 5\%$ of value measured in A.1.1. Increase of $\tan \delta$ $\leq 0,005$ for $C_R \leq 100$ nF, $\leq 0,01$ for $C_R > 100$ nF and ≤ 220 nF, $\leq 0,015$ for $C_R > 220$ nF and ≤ 470 nF, $\leq 0,003$ for $C_R > 470$ nF compared to values measured in A.1.1.</p> <p>As in GENERAL DATA of this specification.</p>
<p>Sub-group ADD2</p> <p>A.2 Endurance for capacitors with max. a.c. voltage ≥ 200 V (r.m.s.)</p> <p>A.2.1 Initial measurements</p> <p>A.2.2 Final measurements</p>		<p>Duration: 1000 h Temperature: 85 °C Voltage: 1,25 x max. a.c. voltage (r.m.s. value), 50 Hz</p> <p>Capacitance Tangent of loss angle for $C_R \leq 470$ nF at 100 kHz, $C_R > 470$ nF at 10 kHz</p> <p>Capacitance Tangent of loss angle</p> <p>Insulation resistance</p>	<p>$\Delta C/C \leq 5\%$ of value measured in A.2.1.</p> <p>Increase of $\tan \delta$ $\leq 0,005$ for $C_R \leq 100$ nF, $\leq 0,01$ for $C_R > 100$ nF and ≤ 220 nF, $\leq 0,015$ for $C_R > 220$ nF and ≤ 470 nF, $\leq 0,003$ for $C_R > 470$ nF compared to values measured in A.2.1.</p> <p>As in GENERAL DATA of this specification.</p>

performance requirements
2222 344-370-371

performance requirements
2222 365 to 369

$\Delta C/C \leq 3\%$ of value measured in A.1.1.
Increase of $\tan \delta \leq 0,005$ ($\leq 0,01$ for 2222 370 and 371) for $C_R \leq 100$ nF, $\leq 0,01$ for $C_R > 100$ nF and ≤ 220 nF, $\leq 0,015$ for $C_R > 220$ nF and ≤ 470 nF, $\leq 0,003$ for $C_R > 470$ nF compared to values measured in A1.1.
As in GENERAL DATA of this specification.

$\Delta C/C \leq 3\%$ of value measured in A.1.1.
Increase of $\tan \delta \leq 0,005$ for $C_R \leq 100$ nF, $\leq 0,01$ for $C_R > 100$ nF and ≤ 220 nF, $\leq 0,015$ for $C_R > 220$ nF and ≤ 470 nF, $\leq 0,003$ for $C_R > 470$ nF compared to values measured in A.1.1.

As in GENERAL DATA of this specification.

$\Delta C/C \leq 3\%$ ($\leq 5\%$ for 2222 370) of value measured in A.2.1.
Increase of $\tan \delta \leq 0,005$ for $C_R \leq 100$ nF, $\leq 0,01$ for $C_R > 100$ nF and ≤ 220 nF, $\leq 0,015$ for $C_R > 220$ nF and ≤ 470 nF, $\leq 0,003$ for $C_R > 470$ nF compared to values measured in A.2.1.
As in GENERAL DATA of this specification.

$\Delta C/C \leq 5\%$ of value measured in A.2.1.

Increase of $\tan \delta \leq 0,005$ for $C_R \leq 100$ nF, $\leq 0,01$ for $C_R > 100$ nF and ≤ 220 nF, $\leq 0,015$ for $C_R > 220$ nF and ≤ 470 nF, $\leq 0,003$ for $C_R > 470$ nF compared to values measured in A.2.1.
As in GENERAL DATA of this specification.

additional tests	D or ND	conditions of test	performance requirements 2222 341
<p>Sub-group ADD3</p> <p>A.3 Solvent resistance, Mil STD-202F, method 215 B</p> <p>A.3.1 Initial measurements</p> <p>A.3.2 Final measurements</p>		<p>GROUP 1: De-ionized water, followed by mixture of isopropyl alcohol and mineral spirits</p> <p>GROUP 2: 1-1-1-Trichloroethane</p> <p>GROUP 3: Azeotropic mixture of trichlorotrifluoroethane and methylene chloride Temperature: 25 °C</p> <p>Capacitance Tangent of loss angle for $C_R \leq 470$ nF at 100 kHz, $C_R > 470$ nF at 10 kHz</p> <p>Capacitance</p> <p>Tangent of loss angle</p> <p>Insulation resistance</p>	<p>$\Delta C/C \leq 1\%$ of value measured in A.3.1.</p> <p>Increase of $\tan \delta$ $\leq 0,005$ for $C_R \leq 100$ nF, $\leq 0,01$ for $C_R > 100$ nF and ≤ 220 nF, $\leq 0,015$ for $C_R > 220$ nF and ≤ 470 nF, $\leq 0,003$ for $C_R > 470$ nF compared to values measured in A.3.1.</p> <p>$\geq 50\%$ of values in GENERAL DATA of this specification.</p>

performance requirements
2222 344-370-371

performance requirements
2222 365 to 369

$\Delta C/C \leq 1\%$ of value measured in A.3.1.
Increase of $\tan \delta$
 $\leq 0,005$ for $C_R \leq 100$ nF,
 $\leq 0,01$ for $C_R > 100$ nF and
 ≤ 220 nF,
 $\leq 0,015$ for $C_R > 220$ nF and
 ≤ 470 nF,
 $\leq 0,003$ for $C_R > 470$ nF
compared to values measured in A.3.1.
 $\geq 50\%$ of values in GENERAL DATA of this specification.

$\Delta C/C \leq 1\%$ of value measured in A.3.1.
Increase of $\tan \delta$
 $\leq 0,005$ for $C_R \leq 100$ nF,
 $\leq 0,01$ for $C_R > 100$ nF and
 ≤ 220 nF,
 $\leq 0,015$ for $C_R > 220$ nF and
 ≤ 470 nF,
 $\leq 0,003$ for $C_R > 470$ nF
compared to values measured in A.3.1.
 $\geq 50\%$ of values in GENERAL DATA of this specification.

additional tests	D or ND	conditions of test	performance requirements 2222 341
<p>Sub-group ADD4</p> <p>A.4 Detergent resistance</p> <p>A.4.1 Initial measurements</p> <p>A.4.2 Final measurements</p>		<p>Density 20g/l dishwasher detergent.</p> <p>Temperature 70 °C, during 3 min.</p> <p>Followed by rinsing in clear water for 1 min.</p> <p>Recovery time > 2 h.</p> <p>Capacitance</p> <p>Tangent of loss angle for $C_R \leq 470$ nF at 100 kHz, $C_R > 470$ nF at 10 kHz</p> <p>Capacitance</p> <p>Tangent of loss angle</p> <p>Insulation resistance</p>	<p>$\Delta C/C \leq 1\%$ of value measured in A.4.1.</p> <p>Increase of $\tan \delta$</p> <p>$\leq 0,005$ for $C_R \leq 100$ nF,</p> <p>$\leq 0,01$ for $C_R > 100$ nF and ≤ 220 nF,</p> <p>$\leq 0,015$ for $C_R > 220$ nF and ≤ 470 nF,</p> <p>$\leq 0,003$ for $C_R > 470$ nF compared to values measured in A.4.1.</p> <p>$\geq 50\%$ of values in GENERAL DATA of this specification.</p>

performance requirements
2222 344-370-371

performance requirements
2222 365 to 369

$\Delta C/C \leq 1\%$ of value measured in A.4.1.
Increase of $\tan \delta$
 $\leq 0,005$ for $C_R \leq 100$ nF,
 $\leq 0,01$ for $C_R > 100$ nF and ≤ 220 nF,
 $\leq 0,015$ for $C_R > 220$ nF and ≤ 470 nF,
 $\leq 0,003$ for $C_R > 470$ nF compared to values measured in A.4.1.
 $\geq 50\%$ of values in GENERAL DATA of this specification.

$\Delta C/C \leq 1\%$ of value measured in A.4.1.
Increase of $\tan \delta$
 $\leq 0,005$ for $C_R \leq 100$ nF,
 $\leq 0,01$ for $C_R > 100$ nF and ≤ 220 nF,
 $\leq 0,015$ for $C_R > 220$ nF and ≤ 470 nF,
 $\leq 0,003$ for $C_R > 470$ nF compared to values measured in A.4.1.
 $\geq 50\%$ of values in GENERAL DATA of this specification.

additional tests	D or ND	conditions of tests	performance requirements 2222 341
<p>Sub-group ADD5</p> <p>A.5 Resistance to soldering heat with pre-heating</p> <p>A.5.1 Initial measurements</p> <p>A.5.2 Final measurements</p>	D	<p>Capacitors mounted on a 1,6 mm board with non-plated holes</p> <p>Body temp.: 80 °C</p> <p>Bath temp.: 260 °C</p> <p>Dwell time: 2 x 5 s with interim free period of 5 s*</p> <p>Capacitance</p> <p>Tangent of loss angle for $C_R \leq 470$ nF at 100 kHz, $C_R > 470$ nF at 10 kHz</p> <p>Capacitance</p> <p>Tangent of loss angle</p>	<p>$\Delta C/C \leq 2\%$ for $C \leq 10$ nF, $\leq 1\%$ for $C > 10$ nF of value measured in A.5.1.</p> <p>Increase of $\tan \delta$</p> <p>$\leq 0,005$ for $C_R \leq 100$ nF, $\leq 0,01$ for $C_R > 100$ nF and ≤ 220 nF, $\leq 0,015$ for $C_R > 220$ nF and ≤ 470 nF, $\leq 0,003$ for $C_R > 470$ nF compared to values measured in A.5.1.</p>

* For style 2222 341: dwell time = 5 s.

performance requirements
2222 344-370-371

performance requirements
2222 365 to 369

$\leq 2\%$ for $T_{\max} = 2,5$ mm,
 $\leq 1\%$ for $T_{\max} > 2,5$ mm of
value measured in A.5.1.

Increase of $\tan \delta$

$\leq 0,005$ for $C_R \leq 100$ nF,
 $\leq 0,01$ for $C_R > 100$ nF and
 ≤ 220 nF,
 $\leq 0,015$ for $C_R > 220$ nF and
 ≤ 470 nF,
 $\leq 0,003$ for $C_R > 470$ nF
compared to values
measured in A.5.1.

$\Delta C/C \leq 2\%$ for $C \leq 10$ nF,
 $\leq 1\%$ for $C > 10$ nF of
value measured in A.5.1.

Increase of $\tan \delta$

$\leq 0,005$ for $C_R \leq 100$ nF,
 $\leq 0,01$ for $C_R > 100$ nF and
 ≤ 220 nF,
 $\leq 0,015$ for $C_R > 220$ nF and
 ≤ 470 nF,
 $\leq 0,003$ for $C_R > 470$ nF
compared to values
measured in A.5.1.

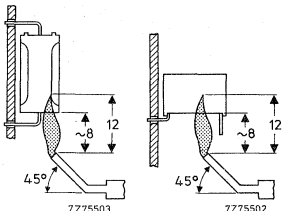
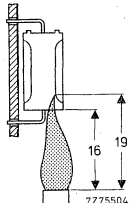
additional tests	D or ND	conditions of test	performance requirements 2222 341
<p>Sub-group ADD6 A.6.1 Needle flame test, IEC 695-2-2</p>	<p>D</p>	<p>Bore of gas jet: ϕ 0,5 mm. Fuel: Butane. Test duration: 20 s One flame application.</p> 	<p>After removing the test flame from the capacitor, the capacitor must not continue to burn for more than 15 s, no burning particles must drop from the sample.</p>
<p>A.6.2 Needle flame test, UL 1414</p>		<p>Bore of gas jet: ϕ 10 mm. Fuel: natural gas. Test duration: 3 x 15 s. Time interval between each flame application: 15 s.</p> 	<p>Extinguishing time \leq 15 s after the first and second flame application, \leq 60 s after the third flame application.</p>
<p>Sub-group ADD7 A.7 Climatic test on taped types</p>		<p>250 h at 40 ± 2 °C R.H. 90 to 95% Recovery time 24 h.</p>	<p>Not applicable.</p>

performance requirements 2222 344-370-371	performance requirements 2222 365 to 369
<p>Only applicable to 2222 344 After removing the test flame from the capacitor, the capacitor must not continue to burn for more than 15 s, no burning particles must drop from the sample.</p>	<p>Not applicable.</p>
<p>Not applicable.</p>	<p>Not applicable.</p>
<p>Only applicable to 2222 370 and 371 Change in position of lead hole over 10 pitch distances $\leq 0,05$ mm. Angle of component $\leq 4^\circ$. Pull off, pull out and tearing forces $\geq 50\%$ of values in GENERAL DATA of this specification.</p>	<p>Only applicable to 2222 365 Change in position of lead hole over 10 pitch distances $\leq 0,05$ mm. Angle of component $\leq 4^\circ$. Pull off, pull out and tearing forces $\geq 50\%$ of values in GENERAL DATA of this specification.</p>

POLYETHYLENETHEREPTHALATE FILM/FOIL CAPACITORS
(KT)

POLYETHYLENETEREPHTHALATE FILM/FOIL CAPACITORS

KT radial phenolic lacquered type

- 10,16 to 27,94 mm pitch
- Supplied in boxes

QUICK REFERENCE DATA

Rated capacitance range (E12-series)	0,001 to 1 μ F
Tolerance on rated capacitance	$\pm 20\%$, $\pm 10\%$
Rated voltage U_R (d.c.)	100 V, 250 V, 400 V, 630 V
Climatic category, IEC 68	40/100/21
Rated temperature	85 °C
Related specification	IEC 384-11

STYLE

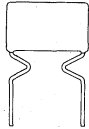

Style: 2222 347.

Pitch: 10,16 mm, 15,24 mm, 22,86 mm, 27,94 mm

See Tables 1 to 4.

APPLICATION

For use in wide range of consumer and industrial applications, especially where high currents and/or steep pulses occur. The capacitors are suited for d.c. or a.c. operation.

DESCRIPTION

These capacitors consist of a low-inductance wound cell of metal foil and a polyethyleneterephthalate (PETP) film. The cell is protected by a hard, tan coloured lacquer, which is self-extinguishing. The radial leads are of solder-coated wire.

GENERAL DATA

Dimensions in mm

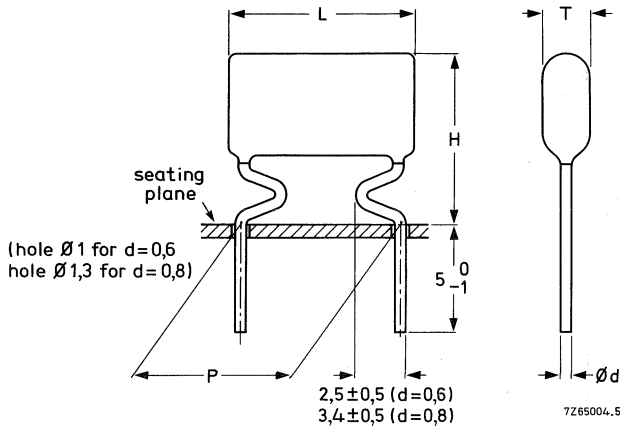

Fig. 1.

Table 1 U_R (d.c.) = 100 V; max. a.c. voltage = 50 V, Fig. 1

rated capacitance μF	T_{max}	H_{max}	L_{max}	d	P	mass g	catalogue number 2222 347	
							tol. $\pm 20\%$	tol. $\pm 10\%$
0,015	4,5	12	13,5	0,6 $+0,06$ $-0,05$	10,16 $\pm 0,3$	0,4	20153	21153
0,018	5	12,5				0,5	20183	21183
0,022	5,5	13				0,6	20223	21223
0,027	5,5	13				0,7	20273	21273
0,033	6	13,5				0,7	20333	21333
0,039	6,5	14				0,8	20393	21393
0,047	7	14,5				0,9	20473	21473
0,056	5,5	14	19	0,8 $+0,08$ $-0,05$	15,24 $\pm 0,3$	1,2	20563	21563
0,068	6	14,5				1,3	20683	21683
0,082	6,5	15				1,5	20823	21823
0,10	7	15,5				1,7	20104	21104
0,12	7,5	16				1,9	20124	21124
0,15	8	16,5				2,3	20154	21154
0,18	7,5	18				27	22,86 $\pm 0,3$	2,8
0,22	7,5	18,5	3,2	20224	21224			
0,27	8	19,5	3,8	20274	21274			
0,33	8,5	20	4,4	20334	21334			
0,39	9,5	21	5,1	20394	21394			
0,47	10,5	22	6,0	20474	21474			
0,56	10	21,5	32	27,94 $\pm 0,3$	7,0			20564
0,68	11	22,5			8,4	20684	21684	
0,82	12	23,5			10,2	20824	21824	
1	13,5	25			12,5	20105	21105	

Table 2 U_R (d.c.) = 250 V; max. a.c. voltage = 80 V, Fig. 1

rated capacitance μF	T_{max}	H_{max}	L_{max}	d	P	mass g	catalogue number 2222 347	
							tol. $\pm 20\%$	tol. $\pm 10\%$
0,0082	4,5	12	13,5	0,6 + 0,06 -0,05	10,16 $\pm 0,3$	0,4	40822	41822
0,010	5	12,5				0,5	40103	41103
0,012	5,5	13				0,5	40123	41123
0,015	5,5	13				0,6	40153	41153
0,018	6	13,5				0,7	40183	41183
0,022	6,5	14				0,8	40223	41223
0,027	7	14,5				0,9	40273	41273
0,033	5,5	14	19	0,8 + 0,08 -0,05	15,24 $\pm 0,3$	1,1	40333	41333
0,039	6	14,5				1,3	40393	41393
0,047	6,5	15				1,4	40473	41473
0,056	7	15,5				1,6	40563	41563
0,068	7,5	16				1,8	40683	41683
0,082	8	16,5				2,1	40823	41823
0,10	7,5	18				27	0,8 + 0,08 -0,05	22,86 $\pm 0,3$
0,12	7,5	18,5	3,0	40124	41124			
0,15	8	19,5	3,5	40154	41154			
0,18	8,5	20	4,0	40184	41184			
0,22	9,5	21	4,5	40224	41224			
0,27	10,5	22	5,3	40274	41274			
0,33	10	21,5	32	0,8 + 0,08 -0,05	27,94 $\pm 0,3$			
0,39	11	22,5				7,6	40394	41394
0,47	12	23,5				9,1	40474	41474
0,56	13,5	25				10,8	40564	41564
0,68	15	26,5				13,1	40684	41684

Table 3 U_R (d.c.) = 400 V; max. a.c. voltage = 125 V, Fig. 1

rated capacitance μF	T_{max}	H_{max}	L_{max}	d	P	mass g	catalogue number 2222 347	
							tol. $\pm 20\%$	tol. $\pm 10\%$
0,0047	4,5	12	13,5	0,6 + 0,06 -0,05	10,16 $\pm 0,3$	0,4	50472	51472
0,0056	5	12,5				0,5	50562	51562
0,0068	5,5	13				0,5	50682	51682
0,0082	5,5	13				0,6	50822	51822
0,010	6	13,5				0,7	50103	51103
0,012	6,5	14				0,8	50123	51123
0,015	7	14,5				0,9	50153	51153
0,018	5,5	14	19		15,24 $\pm 0,3$	1,1	50183	51183
0,022	6	14,5				1,2	50223	51223
0,027	6,5	15				1,4	50273	51273
0,033	7	15,5				1,6	50333	51333
0,039	7,5	16				1,8	50393	51393
0,047	8	16,5				2,1	50473	51473
0,056	7,5	18				27	0,8 + 0,08 -0,05	22,86 $\pm 0,3$
0,068	7,5	18,5	2,9	50683	51683			
0,082	8	19,5	3,2	50823	51823			
0,10	8,5	20	3,8	50104	51104			
0,12	9,5	21	4,4	50124	51124			
0,15	10,5	22	5,2	50154	51154			
0,18	10	21,5	32		27,94 $\pm 0,3$			
0,22	11	22,5				6,9	50224	51224
0,27	12	23,5				8,0	50274	51274
0,33	13,5	25				9,5	50334	51334

Table 4 U_R (d.c.) = 630 V; max. a.c. voltage = 200 V, Fig. 1

rated capacitance μF	T_{max}	H_{max}	L_{max}	d	P	mass g	catalogue number 2222 347	
							tol. $\pm 20\%$	tol. $\pm 10\%$
0,001	5,5	13				0,5	60102	61102
0,0012	5,5	13				0,5	60122	61122
0,0015	5,5	13				0,6	60152	61152
0,0018	5,5	13				0,7	60182	61182
0,0022	5,5	13				0,5	60222	61222
0,0027	5,5	13	13,5	0,6	10,16	0,6	60272	61272
0,0033	5,5	13		+ 0,06	$\pm 0,3$	0,5	60332	61332
0,0039	5,5	13		-0,05		0,6	60392	61392
0,0047	6	13				0,7	60472	61472
0,0056	6,5	14				0,8	60562	61562
0,0068	7	14,5				0,9	60682	61682
0,0082	5,5	14				1,1	60822	61822
0,010	6	14,5				1,2	60103	61103
0,012	6,5	15	19			1,3	60123	61123
0,015	7	15,5				1,5	60153	61153
0,018	7,5	16				1,7	60183	61183
0,022	8	16,5				2,0	60223	61223
0,027	7,5	18				2,5	60273	61273
0,033	7,5	18,5				2,8	60333	61333
0,039	8	19,5	27	0,8	22,86	3,0	60393	61393
0,047	8,5	20		+ 0,08	$\pm 0,3$	3,5	60473	61473
0,056	9,5	21		-0,05		3,8	60563	61563
0,068	10,5	22				4,4	60683	61683
0,082	10	21,5				5,2	60823	61823
0,1	11	22,5	32			6,2	60104	61104
0,12	12	23,5				7,2	60124	61124
0,15	13,5	25				8,7	60154	61154

Marking

- a. Rated capacitance
- b. Rated voltage
- c. Tolerance on rated capacitance
- d. Category voltage
- e. Year and month of manufacture
- f. Manufacturer's name
- g. Climatic category
- h. Manufacturer's type designation

The capacitors are marked in black ink on top with 'a, b, c, f and h as follows:

1st line : rated capacitance in pF or μF , tolerance ($\pm 20\%$ indicated by M or 20%, $\pm 10\%$ indicated by K or 10%);

2nd line : rated d.c. voltage and code for dielectric material (KT)

The manufacturer's name is indicated at the left.

The code for factory of origin is indicated at the right.

The package containing the capacitors is marked with a to h.

Mounting

The capacitors are for printed-wiring applications.

Ratings and characteristics

Unless otherwise specified all electrical values apply at an ambient free air temperature of $23 \pm 1 \text{ }^\circ\text{C}$, an atmospheric pressure of 86 to 106 kPa and a relative humidity of $50 \pm 2\%$.

Capacitance

Rated capacitance range at 1 kHz

see Tables 1 to 4

Tolerance on rated capacitance

see Tables 1 to 4

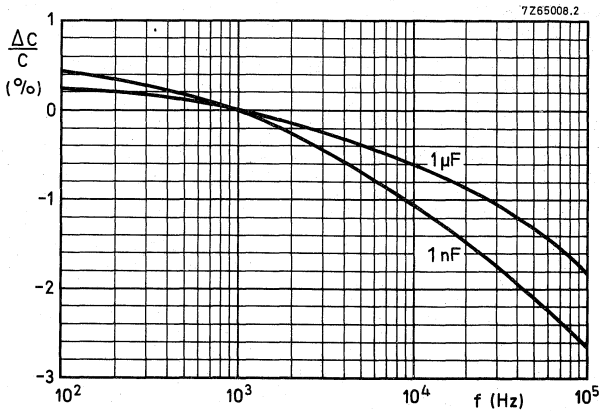

Fig. 2 Capacitance as a function of frequency; typical curves.

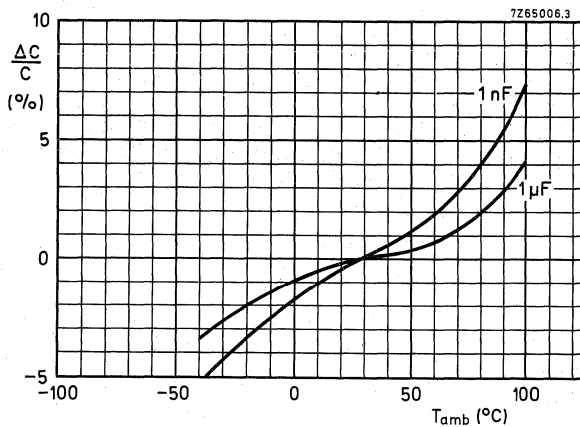

Fig. 3 Capacitance as a function of ambient free air temperature; typical curves.

Voltage

Rated voltage U_R (d.c.)	See Tables 1 to 4
Category voltage U_C	$0,8 \times U_R$ (d.c.)
Maximum a.c. voltage (r.m.s. value), at 50 to 60 Hz	See Tables 1 to 4
Test voltage between terminations	$2 \times U_R$ (d.c.)

Notes

- The sum of the d.c. voltage and the peak value of the superimposed a.c. voltage must be $\leq U_R$ (d.c.)
- For waveforms other than sinusoidal the maximum permissible dissipation must not be exceeded.

Temperature

Climatic category	40/100/21
Rated temperature	85 °C
Storage temperature range	-40 to + 100 °C

Tangent of the loss angle

Tan δ at 10 kHz	$\leq 110 \times 10^{-4}$
Tan δ at 1 kHz	$\leq 60 \times 10^{-4}$

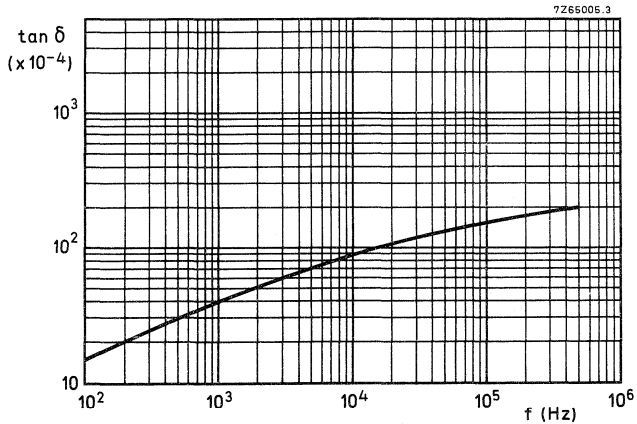

Fig. 4 Tan δ as a function of frequency; typical curve.

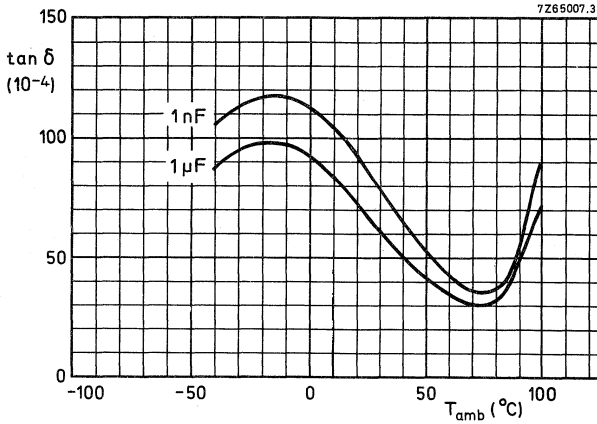

Fig. 5 $\tan \delta$ as a function of ambient free air temperature; typical curves.

Insulation resistance

The insulation resistance is measured after a voltage has been applied for $1\text{ min} \pm 5\text{ s}$, the voltage being $100 \pm 15\text{ V}$ for the 100 V , 250 V and 400 V versions, and $500 \pm 50\text{ V}$ for the 630 V version, at $T_{amb} = 20\text{ }^{\circ}\text{C}$.

R between terminations, for $C_R \leq 0,33\text{ }\mu\text{F}$ $> 50\,000\text{ M}\Omega$

RC between terminations, for $C_R > 0,33\text{ }\mu\text{F}$ $> 16\,500\text{ s}$

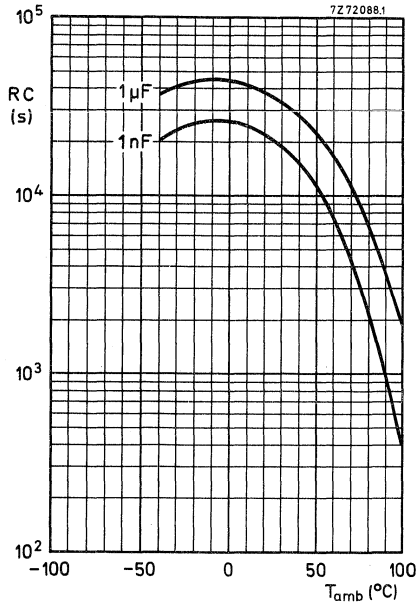

Fig. 6 RC-product as a function of ambient free air temperature; typical curves.

Maximum dissipation

The maximum a.c. voltage has been specified for 50 to 60 Hz and at 23 °C. This voltage must also never be exceeded at other frequencies. This permissible a.c. voltage may further be limited by the maximum power dissipation P_{\max} .

The power dissipated by a capacitor is a function of the voltage across the series resistance (R_s) or of the current through the series resistance and is expressed by

$$P = \frac{V_{R_s}^2}{R_s} = I^2 R_s \quad (1)$$

$$V_{R_s}^2 = \frac{R_s^2}{R_s^2 + 1/\omega^2 C^2} V_{ac}^2 \quad (2a)$$

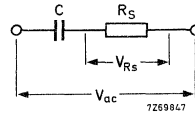

Because for these capacitors $\tan \delta = R_s \omega C < 0,1$, the formule (2a) can be simplified to

$$V_{R_s}^2 = \frac{R_s^2}{1/\omega^2 C^2} V_{ac}^2 = R_s^2 \omega^2 C^2 V_{ac}^2 \quad (2b)$$

$$\text{Thus } P = R_s \omega^2 C^2 V_{ac}^2 \quad (3a)$$

$$\text{or } P = (R_s C) C \omega^2 V_{ac}^2 \quad (3b)$$

The term $R_s C$ can be found from Fig. 7; C (in farads), $\omega = 2\pi f$ and V_{ac} are assumed to be known.

The maximum permissible value of power dissipation (P_{\max}), which depends on the dimensions of the capacitor and on the ambient free air temperature, can be read from Fig. 8.

Thus, when the actual power has been calculated with equation (3b), Fig. 8 gives the minimum size of capacitor which can dissipate this power.

Example of using Fig. 7 and Fig. 8

A capacitor with a value of $0,047 \mu\text{F}$ should be used at an a.c. voltage of 100 V, a frequency of 10 kHz and an ambient free air temperature of 50 °C. Thus the rated d.c. voltage should be at least 400 V.

The $R_s C$ -product is $1,35 \times 10^{-7} \text{ s}$ (from Fig. 7), so that the power to be dissipated is

$$\begin{aligned} P &= (R_s C) C \omega^2 V_{ac}^2 \\ &= 1,35 \times 10^{-7} \times 0,047 \times 10^{-6} \times 4\pi^2 \times 10^8 \times 10^4 = 250 \text{ mW} \end{aligned}$$

For an a.c. voltage of 100 V a capacitor of the 400 V series is required at least.

Capacitor $0,047 \mu\text{F}/125 \text{ V(a.c.)}$ is satisfactory because of its dimensions 8 mm x 16,5 mm x 19 mm, and its dissipated power of 400 mW at 50 °C.

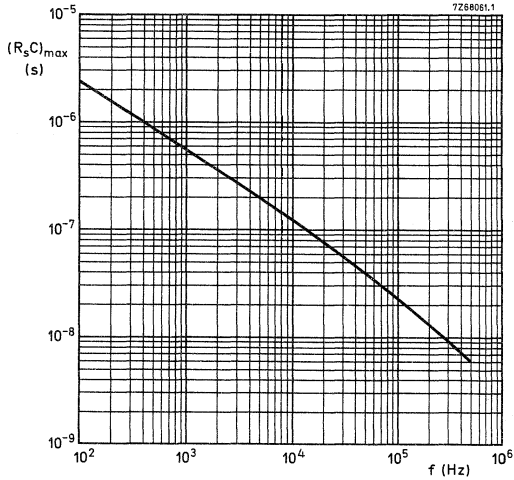

Fig. 7 Maximum product of series resistance and capacitance as a function of frequency.

curve	dimensions in mm		
	T _{max}	H _{max}	L _{max}
1	4,5	12	13,5
2	5	12,5	13,5
3	5,5	13	13,5
4	6	13,5	13,5
5	6,5	14	13,5
6	7	14,5	13,5
7	5,5	14	19
8	6	14,5	19
9	6,5	15	19
10	7	15,5	19
11	7,5	16	19
12	8	16,5	19
13	6,5	18	27
14	7,5	18,5	27
15	8	19,5	27
16	8,5	20	27
17	9,5	21	27
18	10,5	22	27
19	10	21,5	32
20	11	22,5	32
21	12	23,5	32
22	13,5	25	32
23	15	26,5	32

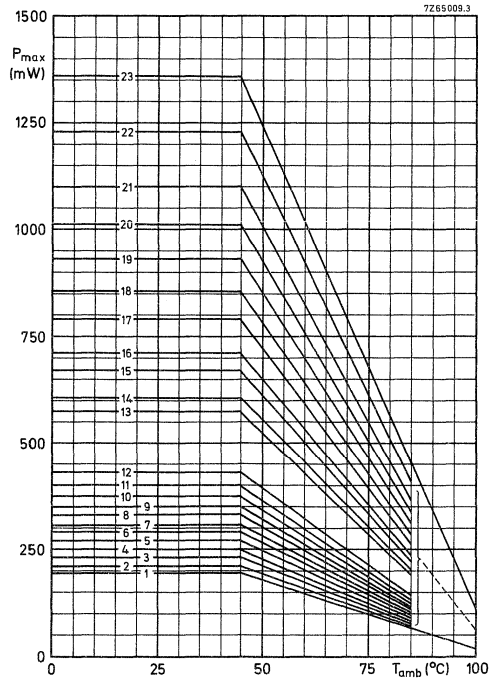

Fig. 8 Maximum dissipation as a function of ambient free air temperature.

ORDERING INFORMATION

Order the capacitors by quoting the 12-digit catalogue number as shown in Tables 1 to 4.

PACKING

The capacitors are packed in boxes; the number of capacitors per box is given in the table below.

dimensions (mm) $T_{\max} \times H_{\max} \times L_{\max}$	number of capacitors per box
$\geq 4,5 \times 12 \times 13,5$ and $\leq 7,5 \times 16 \times 19$	2000
$> 7,5 \times 16 \times 19$ and $\leq 7,5 \times 18,5 \times 27$	1000
$> 7,5 \times 18,5 \times 27$ and $\leq 11 \times 22,5 \times 32$	500
$> 11 \times 22,5 \times 32$	250

INSPECTION REQUIREMENTS

polyethyleneterephthalate film/foil capacitors (KT)

Note 1

Sub-clause numbers of tests and performance requirements refer to the Sectional Specification, IEC-publication 384-11 and GENERAL DATA of this specification.

Note 2

In this table: D = destructive, ND = non-destructive.

clause number and test (see Note 1)	D or ND	conditions of test (see Note 1)	performance requirements (see Note 1)
Group A Inspection (lot-by-lot)			
Sub-group A1			
4.1 Visual examination	ND		<ul style="list-style-type: none"> – No mechanical failures – Legible marking and as specified in GENERAL DATA of this specification.
4.2 Dimensions		Gauging	<ul style="list-style-type: none"> – As specified in Tables 1 to 4 of this specification.
Sub-group A2			
4.2.1 Voltage proof (Test A)	ND	at $2,2 \times U_R$ (d.c.) for 1 s	<ul style="list-style-type: none"> – No breakdown or flashover.
4.2.2 Capacitance		at 1 kHz	<ul style="list-style-type: none"> – Within specified tolerance.

sub-clause number and test (see Note 1)	D or ND	conditions of test (see Note 1)	performance requirements
Group B Inspection (periodic) 4.5 Solderability	D	Without ageing Method: 1 Solder bath: 235 °C Dwell time: 2 s Non-activated colophony flux	Good tinning as evidenced by free flowing of the solder with wetting of the terminations.
Group C Inspection (periodic)			
Sub-group C1A	D		
Part of sample of Sub-group C1			
4.1 Dimensions (detail)			As specified in Tables 1 to 4 of this specification.
4.3.1 Initial measurements		Capacitance at 1 kHz Tangent of loss angle at 10 kHz	
4.3 Robustness of terminations		Tensile and bending	No visible damage.
4.4 Resistance to soldering heat		No pre-drying Method: 1A Solder bath: 260 °C Duration: 10 s	
4.2.2 Final measurements		Visual examination	No visible damage.
		Capacitance	Legible marking. $\Delta C/C \leq 2\%$ of the value measured in 4.3.1.

sub-clause number and test (see Note 1)	D or ND	conditions of test (see Note 1)	performance requirements
<p>Sub-group C1B Other part of sample of Sub-group C1</p>			
<p>4.6.1 Initial measurements</p>		<p>Capacitance at 1 kHz Tangent of loss angle at 10 kHz</p>	
<p>4.6 Rapid change of temperature</p>		<p>θ A = lower cat. temp. θ B = upper cat. temp. 5 cycles, duration t = 30 min. Visual examination</p>	<p>No visible damage.</p>
<p>4.7 Vibration</p>		<p>Method of mounting see Note below. Procedure B4. Frequency range: 10 to 55 Hz Pulse shape: half sine Amplitude: 0,75 mm or acceleration: 98 m/s² (whichever is the less severe). Total duration: 6 h</p>	
<p>4.7.2 Final inspection</p>		<p>Visual examination</p>	<p>No visible damage.</p>
<p>4.9 Shock</p>		<p>Method of mounting see Note below. Pulse shape: half sine Acceleration: 390 m/s² Duration of pulse: 6 ms</p>	
<p>4.9.3 Final measurements</p>		<p>Visual examination Capacitance Tangent of loss angle</p>	<p>No visible damage. $\Delta C/C \leq 2\%$ of the value measured in 4.6.1. As in GENERAL DATA of this specification.</p>

Note:

The capacitors shall be mechanically fixed by the leads and the crimps shall be in good contact with the printed-wiring board, also the body of capacitors with a mass > 2 g shall be clamped to the printed-wiring board.

sub-clause number and test (see Note 1)	D or ND	conditions of test (see Note 1)	performance requirements
<p>Sub-group C1 Combined sample of specimens of Sub-groups C1A and C1B</p> <p>4.10 Climatic sequence</p> <p>4.10.2 Dry heat</p> <p>4.10.3 Damp heat cyclic, Test Db, first cycle</p> <p>4.10.4 Cold</p> <p>4.10.6 Damp heat cyclic, Test Db, remaining cycles</p> <p>4.10.6.2 Final measurements</p>	D	<p>Temperature: upper category temperature Duration: 16 h</p> <p>Temperature: lower category temperature Duration: 2 h</p>	
		<p>Visual examination</p> <p>Capacitance</p> <p>Tangent of loss angle</p> <p>Insulation resistance</p>	<p>No visible damage. Legible marking. $\Delta C/C \leq 5\%$ of value measured in 4.4.2 or 4.9.3.</p> <p>As in GENERAL DATA of this specification.</p> <p>$\geq 50\%$ of values in GENERAL DATA of this specification.</p>

sub-clause number and test (see Note 1)	D or ND	conditions of test (see Note 1)	performance requirements
<p>Sub-group C2</p> <p>4.11 Damp heat steady state</p> <p>4.11.1 Initial measurements</p> <p>4.11.3 Final measurements</p>	D	<p>Capacitance at 1 kHz Tangent of loss angle at 10 kHz</p> <p>Visual examination</p> <p>Capacitance</p> <p>Tangent of loss angle</p> <p>Insulation resistance</p>	<p>No visible damage. Legible marking. $\Delta C/C \leq 5\%$ of the value measured in 4.11.1.</p> <p>As in GENERAL DATA of this specification.</p> <p>$\geq 50\%$ of values in GENERAL DATA of this specification.</p>
<p>Sub-group C3</p> <p>4.12 Endurance</p> <p>4.12.1 Initial measurements</p> <p>4.12.5 Final measurements</p>	D	<p>Duration: 1000 h; 1,5 U_R (d.c.) at 85 °C, 1,5 U_C at 100 °C</p> <p>Capacitance at 1 kHz Tangent of loss angle at 10 kHz</p> <p>Visual examination</p> <p>Capacitance</p> <p>Tangent of loss angle</p> <p>Insulation resistance</p>	<p>No visible damage. Legible marking. $\Delta C/C \leq 10\%$ of value measured in 4.12.1.</p> <p>As in GENERAL DATA of this specification.</p> <p>$\geq 50\%$ of values in GENERAL DATA of this specification.</p>

additional tests	D or ND	conditions of test	performance requirements
<p>Sub-group ADD1</p> <p>A.1 Heat storage</p> <p>A.1.1 Initial measurements</p> <p>A.1.2 Final measurements</p>	D	<p>Duration: 1000 h Temperature: upper category temperature</p> <p>Capacitance at 1 kHz Tangent of loss angle at 10 kHz</p> <p>Capacitance</p> <p>Insulation resistance</p>	<p>$\Delta C/C \leq 5\%$ of value measured in A.1.1.</p> <p>As in GENERAL DATA of this specification.</p>
<p>Sub-group ADD2</p> <p>A.2 Endurance for capacitors with max. a.c. voltage ≥ 200 V (r.m.s.)</p> <p>A.2.1 Initial measurements</p> <p>A.2.2 Final measurements</p>		<p>Duration: 1000 h Temperature: 85 °C Voltage: 1,25 x max. a.c. voltage (r.m.s. value), 50 Hz</p> <p>Capacitance at 1 kHz Tangent of loss angle at 10 kHz</p> <p>Capacitance</p> <p>Tangent of loss angle</p> <p>Insulation resistance</p>	<p>$\Delta C/C \leq 5\%$ of value measured in A.2.1.</p> <p>As in GENERAL DATA of this specification.</p> <p>As in GENERAL DATA of this specification.</p>

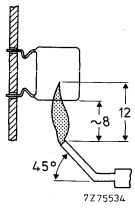
additional tests	D or ND	conditions of tests	performance requirements
<p>Sub-group ADD3</p> <p>A.3 Resistance to soldering heat with pre-heating</p> <p>A.3.1 Initial measurements</p> <p>A.3.2 Final measurements</p>	<p>D</p>	<p>Capacitors mounted on a 1,6 mm board with non-plated holes</p> <p>Body temp.: 80 °C</p> <p>Bath temp.: 260 °C</p> <p>Dwell time: 2 x 5 s, with interim free period of 5 s</p> <p>Capacitance</p> <p>Tangent of loss angle</p> <p>Capacitance</p> <p>Tangent of loss angle</p> <p>Insulation resistance</p>	<p>$\Delta C/C \leq 2\%$ of value measured in A.3.1.</p> <p>As in GENERAL DATA of this specification.</p> <p>As in GENERAL DATA of this specification.</p>
<p>Sub-group ADD4</p> <p>A.4.1 Needle flame test, IEC 695-2-2</p>	<p>D</p>	<p>Bore of gas jet: ϕ 0,5 mm.</p> <p>Fuel: butane.</p> <p>Test duration: 20 s.</p> <p>One flame application.</p> 	<p>After removing the test flame from the capacitor, the capacitor must not continue to burn for more than 15 s, no burning particles must drop from the sample.</p>

MÉTALLIZED POLYCARBONATE FILM CAPACITORS
(MKC)

METALLIZED POLYCARBONATE FILM CAPACITORS

MKC axial moulded type

- Supplied in boxes

QUICK REFERENCE DATA

Rated capacitance range (E12-series)	0,0082 to 6,8 μ F
Tolerance on rated capacitance	$\pm 20\%$, $\pm 10\%$, $\pm 5\%$
Rated voltage U_R (d.c.)	100 V, 250 V, 400 V, 630 V, 1000 V
Climatic category	55/100/56
Rated temperature	85 °C
Tangent of loss angle at 10 kHz	20×10^{-4}
Related specification	IEC 384-6
Performance grade	general purpose

STYLE

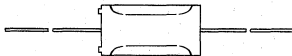

Style 2222 341; see Tables 1 to 5

APPLICATION

In electronic circuits for blocking and coupling, bypass and energy reservoir applications.

DESCRIPTION

The capacitors consist of a low-inductance wound cell of metallized polycarbonate film. The cell is moulded in yellow flame retardent polypropylene. The axial leads are of solder-coated wire. One end of the capacitor is provided with two stand-off ridges to allow removal of solder flux etc., when cleaning the printed-wiring board.

GENERAL DATA

Dimensions in mm

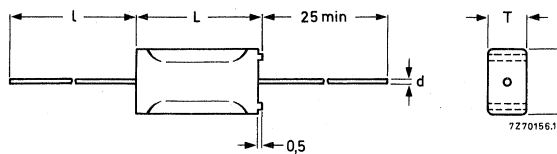

Fig. 1.

Table 1 U_R (d.c.) = 100 V; max. a.c. voltage = 63 V; Fig. 1

rated capacitance μF	T_{max}	H_{max}	L_{max}	d	$\varnothing \text{ min}$	mass g	catalogue number 2222 341			
							tol. $\pm 20\%$	tol. $\pm 10\%$	tol. $\pm 5\%$	
0,082	5,1	8,8	14,6	0,8	40	1,0	28823	29823	23823	
0,10							28104	29104	23104	
0,12							28124	29124	23124	
0,15	5,7	9,5	14,6			1,1	28154	29154	23154	
0,18							28184	29184	23184	
0,22							28224	29224	23224	
0,27	7	10,6	14,6			1,4	28274	29274	23274	
0,33	6,6	10,4	18,1				1,7	28334	29334	23334
0,39								28394	29394	23394
0,47						28474		29474	23474	
0,56	7,9	11,5	18,1			2,0	28564	29564	23564	
0,68	7,8	11,6	23,5				2,5	28684	29684	23684
0,82				28824	29824			23824		
1,0				9,2	12,9	23,5		3,2	28105	29105
1,2	28125	29125	23125							
1,5	10,8	14,5	23,5				4,0		28155	29155
1,8				28185	29185	23185				
2,2				10,7	14,6	31		5,5	28225	29225
2,7	28275	29275	23275							
3,3	12,5	19,5	31				8,0		28335	29335
3,9				28395	29395	23395				
4,7				28475	29475	23475				
5,6	15,4	22,1	31	10,5	28565	29565	23565			
6,8					28685	29685	23685			

Table 2 U_R (d.c.) = 250 V; max. a.c. voltage = 160 V; Fig. 1

rated capacitance μF	T_{max}	H_{max}	L_{max}	d	\varnothing min	mass g	catalogue number 2222 341		
							tol. \pm 20%	tol. \pm 10%	tol. \pm 5%
0,039	5,1	8,8	14,6	0,8	40	1,0	48393	49393	47393
0,047							48473	49473	47473
0,056							48563	49563	47563
0,068	5,7	9,5	14,6			1,4	48683	49683	47683
0,082							48823	49823	47823
0,10							48104	49104	47104
0,12	6,6	10,4	18,1			1,7	48124	49124	47124
0,15							48154	49154	47154
0,18	7,9	11,5	18,1			2,0	48184	49184	47184
0,22							48224	49224	47224
0,27	7,8	11,6	23,5			2,5	48274	49274	47274
0,33							48334	49334	47334
0,39	9,2	12,9	23,5	3,2	48394	49394	47394		
0,47					48474	49474	47474		
0,56	10,8	14,5	23,5	4,0	48564	49564	47564		
0,68					48684	49684	47684		
0,82	10,7	14,6	31	1	50	48824	49824	47824	
1,0						48105	49105	47105	
1,2	12,5	19,5	31			8,0	48125	49125	47125
1,5							48155	49155	47155
1,8	15,4	22,1	31			10,5	48185	49185	47185
2,2							48225	49225	47225

Table 3 U_R (d.c.) = 400 V; max. a.c. voltage = 220 V; Fig. 1

rated capacitance μF	T_{max}	H_{max}	L_{max}	d	l min	mass g	catalogue number 2222 341						
							tol. \pm 20%	tol. \pm 10%	tol. \pm 5%				
0,0082	5,1	8,8	14,6	0,8	40	1,0	58822	59822	57822				
0,010							58103	59103	57103				
0,012							58123	59123	57123				
0,015							58153	59153	57153				
0,018							58183	59183	57183				
0,022							58223	59223	57223				
0,027							58273	59273	57273				
0,033							5,7	9,5	14,6	1,1	58333	59333	57333
0,039							7	10,6	14,6	1,4	58393	59393	57393
0,047							6,6	10,4	18,1	0,8	40	1,7	58473
0,056	58563	59563	57563										
0,068	58683	59683	57683										
0,082	58823	59823	57823										
0,10	7,9	11,5	18,1	2,0	58104	59104							57104
0,12	7,8	11,6	23,5	2,5	58124	59124							57124
0,15	58154	59154	57154										
0,18	58184	59184	57184										
0,22	9,2	12,9	23,5	3,2	58184	59184							57184
0,27	58224	59224	57224										
0,33	10,8	14,5	23,5	4,0	58274	59274	57274						
0,39	10,7	14,6	31	1	50	5,5	58334	59334	57334				
0,47							58394	59394	57394				
0,56							58474	59474	57474				
0,68							58564	59564	57564				
0,82							58684	59684	57684				
1,0							58824	59824	57824				
							15,4	22,1	31	10,5	58105	59105	57105

Table 4 U_R (d.c.) = 630 V; max. a.c. voltage = 220 V; Fig. 1

rated capacitance μF	T_{max}	H_{max}	L_{max}	d	ℓ min	mass g	catalogue number 2222 341		
							tol. \pm 20%	tol. \pm 10%	tol. \pm 5%
0,0082	5,1	8,8	14,6	0,8	40	1,0	60822	61822	62822
0,010							60103	61103	62103
0,012	5,7	9,5	14,6			1,1	60123	61123	62123
0,015							60153	61153	62153
0,018	7	10,6	14,6			1,4	60183	61183	62183
0,022							60223	61223	62223
0,027	6,6	10,4	18,1			1,7	60273	61273	62273
0,033							60333	61333	62333
0,039	7,9	11,5	18,1			2,0	60393	61393	62393
0,047							60473	61473	62473
0,056	7,8	11,6	23,5			2,5	60563	61563	62563
0,068							60683	61683	62683
0,082	9,2	12,9	23,5	3,2	60823	61823	62823		
0,10					60104	61104	62104		
0,12	10,8	14,5	23,5	4,0	60124	61124	62124		
0,15					60154	61154	62154		
0,18	10,7	14,6	31	5,5	60184	61184	62184		
0,22					60224	61224	62224		
0,27	12,5	19,5	31	8,0	60274	61274	62274		
0,33					60334	61334	62334		
0,39	15,4	22,1	31	10,5	60394	61394	62394		
0,47					60474	61474	62474		

Table 5 U_R (d.c.) = 1000 V; max. a.c. voltage = 250 V; Fig. 1

rated capacitance μF	T_{max}	H_{max}	L_{max}	d	\varnothing min	mass g	catalogue number 2222 341	
							tol. \pm 20%	tol. \pm 10%
0,0082	6,6	10,4	18,1	0,8	40	1,7	70822	71822
0,010							70103	71103
0,012	7,9	11,5	18,1			2,0	70123	71123
0,015							70153	71153
0,018	7,8	11,6	23,5			2,5	70183	71183
0,022							70223	71223
0,027	9,2	12,9	23,5			3,2	70273	71273
0,033							70333	71333
0,039	10,8	14,5	23,5			4,0	70393	71393
0,047							70473	71473
0,056	10,7	14,6	31	1	50	5,5	70563	71563
0,068							70683	71683
0,082	12,5	19,5	31			8,0	70823	71823
0,10							70104	71104
0,12	15,4	22,1	31			10,5	70124	71124
0,15							70154	71154

Note: Capacitors of the 1000 V range with tolerance \pm 5% are available to special order.

Marking

- Rated capacitance
- Rated voltage
- Tolerance on rated capacitance
- Category voltage
- Year and month of manufacture
- Manufacturer's name
- Climatic category
- Manufacturer's type designation

The marking is impressed on one side with a, b, c, e and h as follows:

1st line : rated capacitance in pF or μF , tolerance and rated d.c. voltage;

2nd line : 5th, 6th and 7th digits of the catalogue number, code for dielectric material (MKC) and production date code (according to IEC 62, clause 5).

The marking on the other side is impressed with f as follows:

1st line : manufacturer's name;

2nd line : code for factory of origin.

The package containing the capacitors is marked with a to h.

Mounting

The capacitors are for horizontal or vertical mounting on printed-wiring boards and for point to point wiring.

Ratings and characteristics

Unless otherwise specified all electrical values apply to an ambient free air temperature of $23 \pm 1 \text{ }^\circ\text{C}$, an atmospheric pressure of 86 to 106 kPa and a relative humidity of $50 \pm 2\%$.

Capacitance

Rated capacitance range at 1 kHz

see Tables 1 to 5

Tolerance on rated capacitance

see Tables 1 to 5

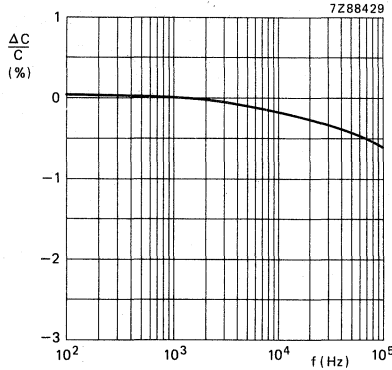

Fig. 2 Capacitance as a function of frequency; typical curve.

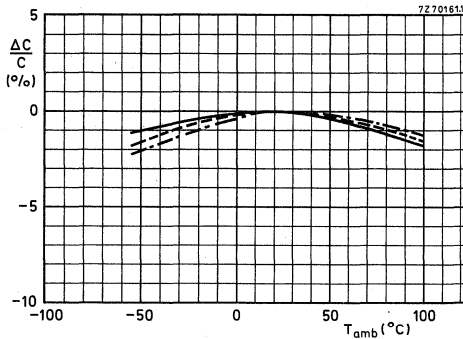

Fig. 3 Capacitance as a function of ambient free air temperature; typical curves.

- for all capacitance values, measured at 1 kHz, 1 V.
- for capacitance values $\leq 1 \text{ } \mu\text{F}$, measured at 10 kHz, 1 V.
- · - · - for capacitance values $\leq 0,1 \text{ } \mu\text{F}$, measured at 100 kHz, 0,3 V.

Voltage

Rated voltage U_R (d.c.)	See Tables 1 to 5
Category voltage U_C	$0,8 \times U_R$ (d.c.)
Maximum a.c. voltage (r.m.s. value), at 50 to 60 Hz	See Tables 1 to 5
Test voltage between terminations	$1,6 \times U_R$ (d.c.)
between interconnected terminations and case	$2 \times U_R$ (d.c.); min. 200 V

Temperature

Climatic category	55/100/56
Rated temperature	85 °C
Storage temperature range	-55 to + 100 °C

Notes

- The sum of the d.c. voltage and the peak value of the superimposed a.c. voltage must be $\leq U_R$ (d.c.)
- For waveforms other than sinusoidal the maximum permissible dissipation must not be exceeded.

Maximum pulse load

rated voltage V	maximum pulse load (V/ μ s)			
	L = 14,5 mm	L = 18 mm	L = 23,5 mm	L = 31 mm
100	30	13	7,5	4,5
250	45	18	12	7
400	70	30	18	11
630	100	45	25	15
1000		45	40	20

The maximum pulse load values in the table are valid for pulse voltages equal to the rated voltage.

For lower pulse voltages the given values may be multiplied by U_R /applied voltage.

Note

If the pulse load requirement is satisfied, a check must be made to ascertain that the maximum dissipation is not exceeded.

Tangent of loss angle

capacitance	tangent of loss angle		
	1 kHz	10 kHz	100 kHz
$C_R \leq 0,1 \mu F$	$\leq 30 \times 10^{-4}$	$\leq 60 \times 10^{-4}$	$\leq 130 \times 10^{-4}$
$0,1 \mu F < C_R \leq 1 \mu F$	$\leq 30 \times 10^{-4}$	$\leq 60 \times 10^{-4}$	
$C_R > 1 \mu F$	$\leq 30 \times 10^{-4}$	$\leq 75 \times 10^{-4}$	

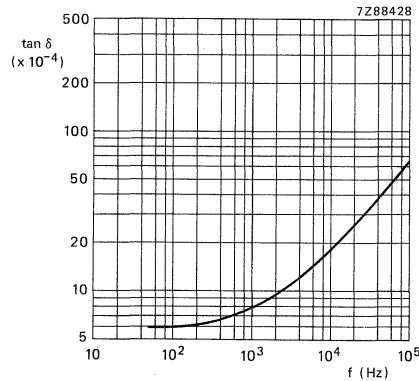

Fig. 4 $\tan \delta$ as a function of frequency, typical curve.

Insulation resistance

The insulation resistance is measured after a voltage has been applied for $1 \text{ min} \pm 5 \text{ s}$, the voltage being $100 \pm 15 \text{ V}$ for the 100 V, 250 V and 400 V versions, and $500 \pm 50 \text{ V}$ for the 630 V and 1000 V versions, at $T_{\text{amb}} = 20 \text{ }^\circ\text{C}$.

R between terminations, for $C_R \leq 0,33 \mu F$

100 V version

$> 15\,000 \text{ M}\Omega$

250 V, 400 V 630 V, 1000 V versions

$> 30\,000 \text{ M}\Omega$

RC between terminations, for $C_R > 0,33 \mu F$

100 V version

$> 5\,000 \text{ s}$

250 V, 400 V, 630 V, 1000 V versions

$> 10\,000 \text{ s}$

R between interconnected terminations and case (foil method)

$> 30\,000 \text{ M}\Omega$

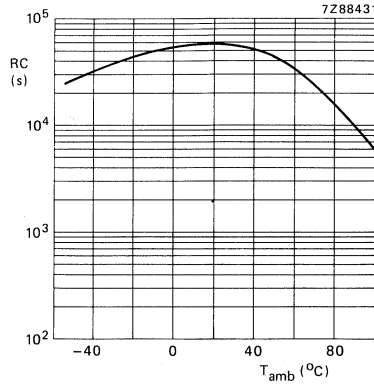

Fig. 5 RC-product as a function of ambient free air temperature; typical curve.

Maximum dissipation

Notes

In applications where voltages higher than 50 V are applied, it is recommended that the power in the capacitor be limited to 2,5 VA in case of capacitor failure.

If the requirement for the maximum dissipation is satisfied, a check must be made to ascertain that the maximum pulse load is not exceeded.

The maximum a.c. voltage has been specified for 50 to 60 Hz and at 23 °C. This voltage value must also never be exceeded at other frequencies. This permissible a.c. voltage may further be limited by the following requirements:

1. The power dissipation must not exceed the specified limit P_{max} .
2. The steepness of the a.c. voltage must not exceed the specified limit.

The power dissipated by a capacitor is a function of the voltage across the series resistance (R_s) or of the current through the series resistance and is expressed by

$$P = \frac{V_{R_s}^2}{R_s} = I^2 R_s \tag{1}$$

$$V_{R_s}^2 = \frac{R_s^2}{R_s^2 + 1/\omega^2 C^2} V_{ac}^2 \tag{2a}$$

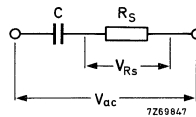

Because for these capacitors $\tan \delta = R_s \omega C = < 0,1$, the formula (2a) can be simplified to

$$V_{R_s}^2 = \frac{R_s^2}{1/\omega^2 C^2} V_{ac}^2 = R_s^2 \omega^2 C^2 V_{ac}^2 \tag{2b}$$

Thus $P = R_s \omega^2 C^2 V_{ac}^2 \tag{3a}$

or $P = (R_s C) C \omega^2 V_{ac}^2 \tag{3b}$

The term $R_s C$ can be found from Fig. 6, C (in farads), $\omega = 2\pi f$ and V_{ac} are assumed to be known.

The maximum permissible value of power dissipation (P_{max}), which depends on the dimensions of the capacitor and on the ambient free air temperature, can be read from Fig. 7.

Thus, when the actual power has been calculated with equation (3b), Fig. 7 gives the minimum size of capacitor which can dissipate this power.

Example of using Figs 6 and 7

A capacitor of $1 \mu\text{F}$ should be used at an a.c. voltage of 130 V, a frequency of 1 kHz and an ambient free air temperature of 50°C .

The $R_s C$ -product is $1,5 \times 10^{-7} \Omega\text{F}$ (from Fig. 6), so that the power to be dissipated is

$$\begin{aligned} P &= (R_s C) C \omega^2 V_{ac}^2 \\ &= 1,5 \cdot 10^{-7} \times 1 \cdot 10^{-6} \times (2\pi)^2 \times 10^6 \times 130^2 \\ &= 100 \text{ mW} \end{aligned}$$

For a rated voltage of 130 Vac a capacitor of the 250 V version is required at least.

Capacitor $1 \mu\text{F}/160 \text{ Vac}$ is satisfactory because of its dimensions $10,7 \text{ mm} \times 14,6 \text{ mm} \times 31 \text{ mm}$ and its dissipated power of 595 mW at 50°C .

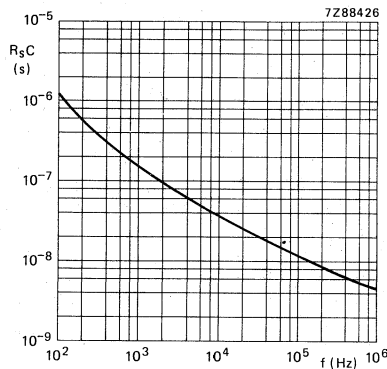

Fig. 6 Maximum product of series resistance and capacitance as a function of frequency.

curve	dimensions (mm)		
	T _{max}	H _{max}	L _{max}
1	5,1	8,8	14,6
2	5,7	9,5	14,6
3	7	10,6	14,6
4	6,6	10,4	18,1
5	7,9	11,5	18,1
6	7,8	11,6	23,5
7	9,2	12,9	23,5
8	10,8	14,5	23,5
9	10,7	14,6	31
10	12,5	19,5	31
11	15,4	22,1	31

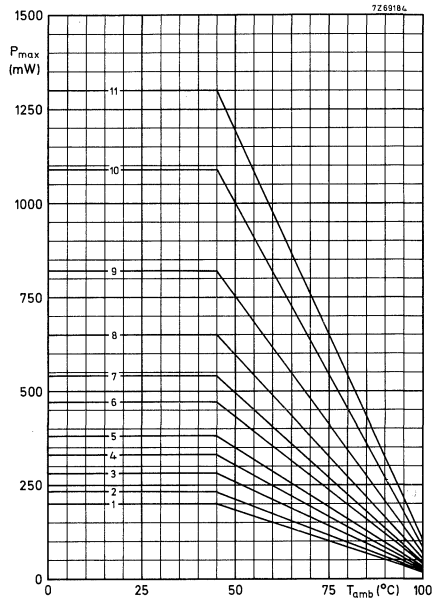

Fig. 7 Maximum dissipation as a function of ambient free air temperature.

ORDERING INFORMATION

Order the capacitors by quoting the 12-digit catalogue number as shown in Tables 1 to 5.

PACKING

The capacitors are packed in boxes of 250 (for $H_{max} \leq 11,5$ mm) and 200 (for $H_{max} > 11,5$ mm).

METALLIZED POLYCARBONATE FILM CAPACITORS

MKC radial potted type

- 10 to 27,5 mm pitch
- Supplied in boxes

QUICK REFERENCE DATA

Rated capacitance range (E12-series)	0,010 to 6,8 μ F
Tolerance on rated capacitance	$\pm 20\%$, $\pm 10\%$, $\pm 5\%$
Rated voltage U_R (d.c.)	100 V, 250 V, 400 V, 630 V
Climatic category	55/100/56
Rated temperature	85 $^{\circ}$ C
Tangent of loss angle at 10 kHz	20×10^{-4}
Related specification	IEC 384-6
Performance grade	long life

STYLE



Style: 2222 344.
Pitch: 10 mm, 15 mm, 22,5 mm, 27,5 mm.
See Tables 1 to 4.

APPLICATION

In electronic circuits for blocking and coupling, bypass and energy reservoir applications. Their defined dimensions make them suitable for circuits with high packaging density.

DESCRIPTION

The capacitors consist of a low-inductance wound cell of metallized polycarbonate film. The cell is potted with epoxy resin in a flame retardent polypropylene case. The radial leads are of solder-coated wire. The capacitors can withstand solvents and rinsing liquids without damage. They have small stand-off pips to allow removal of solder flux etc. during cleaning of the printed-wiring board.

GENERAL DATA

Dimensions in mm

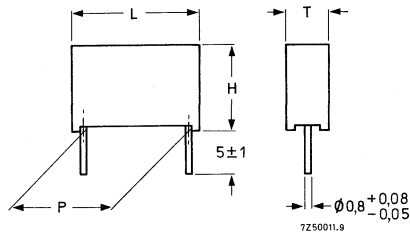

Fig. 1.

Table 1 U_R (d.c.) = 100 V; max. a.c. voltage = 63 V, Fig. 1

rated capacitance μF	T_{max}	H_{max}	L_{max}	P	mass g	catalogue number 2222 344				
						tol. $\pm 20\%$	tol. $\pm 10\%$	tol. $\pm 5\%$		
0,082	4,5	10	13	$10 \pm 0,3$	0,7	20823	21823	22823		
0,10	4,5	10				20104	21104	22104		
0,12	4,5	10				20124	21124	22124		
0,15	4,5	10			20154	21154	22154			
0,18	5	11			20184	21184	22184			
0,22	5	11			20224	21224	22224			
0,27	5	11	17,5	$15 \pm 0,3$	1,05	20274	21274	22274		
0,33	5	11			20334	21334	22334			
0,39	6	11,5			20394	21394	22394			
0,47	6	11,5			20474	21474	22474			
0,56	7	13			20564	21564	22564			
0,68	7	13			20684	21684	22684			
0,82	8,5	14,5			20824	21824	22824			
1,0	8,5	14,5			20105	21105	22105			
1,2	6,5	15,5			26	$22,5 \pm 0,3$	2,75	20125	21125	22125
1,5	6,5	15,5					20155	21155	22155	
1,8	8,5	17,5	20185	21185			22185			
2,2	8,5	17,5	20225	21225			22225			
2,7	9,5	19	20275	21275			22275			
3,3	9,5	19	20335	21335			22335			
3,9	11	20	31	$27,5 \pm 0,3$	7,4	20395	21395	22395		
4,7	11	20			20475	21475	22475			
5,6	13	22,5			20565	21565	22565			
6,8	13	22,5			20685	21685	22685			

Table 2 U_R (d.c.) = 250 V; max. a.c. voltage = 160 V, Fig. 1

rated capacitance μF	T_{max}	H_{max}	L_{max}	P	mass g	catalogue number 2222 344		
						tol. \pm 20%	tol. \pm 10%	tol. \pm 5%
0,039	4,5	10				44393	45393	43393
0,047	4,5	10				44473	45473	43473
0,056	4,5	10	13	$10 \pm 0,3$	0,7	44563	45563	43563
0,068	4,5	10				44683	45683	43683
0,082	5	11			1,05	44823	45823	43823
0,10	5	11				44104	45104	43104
0,12	6	11,5			1,4	44124	45124	43124
0,15	6	11,5	17,5	$15 \pm 0,3$		44154	45154	43154
0,18	7	13			1,8	44184	45184	43184
0,22	7	13				44224	45224	43224
0,27	8,5	14,5			2,55	44274	45274	43274
0,33	8,5	14,5				44334	45334	43334
0,39	6,5	15,5			2,75	44394	45394	43394
0,47	6,5	15,5				44474	45474	43474
0,56	7,5	16,5	26	$22,5 \pm 0,3$	3,5	44564	45564	43564
0,68	7,5	16,5				44684	45684	43684
0,82	9,5	19			5,1	44824	45824	43824
1,0	9,5	19				44105	45105	43105
1,2	11	20			7,4	44125	45125	43125
1,5	11	20				44155	45155	43155
1,8	13	22,5	31	$27,5 \pm 0,3$		44185	45185	43185
2,2	13	22,5			10,2	44225	45225	43225

Table 3 U_R (d.c.) = 400 V; max. a.c. voltage = 220 V, Fig. 1

rated capacitance μF	T_{max}	H_{max}	L_{max}	P	mass g	catalogue number 2222 344		
						tol. $\pm 20\%$	tol. $\pm 10\%$	tol. $\pm 5\%$
0,010	4,5	10				50103	51103	52103
0,012	4,5	10				50123	51123	52123
0,015	4,5	10				50153	51153	52153
0,018	4,5	10	13	$10 \pm 0,3$	0,7	50183	51183	52183
0,022	4,5	10				50223	51223	52223
0,027	4,5	10				50273	51273	52273
0,033	4,5	10				50333	51333	52333
0,039	5	11			1,05	50393	51393	52393
0,047	5	11				50473	51473	52473
0,056	6	11,5			1,4	50563	51563	52563
0,068	6	11,5	17,5	$15 \pm 0,3$		50683	51683	52683
0,082	7	13			1,8	50823	51823	52823
0,10	7	13				50104	51104	52104
0,12	8,5	14,5			2,55	50124	51124	52124
0,15	8,5	14,5				50154	51154	52154
0,18	6,5	15,5			2,75	50184	51184	52184
0,22	6,5	15,5				50224	51224	52224
0,27	7,5	16,5	26	$22,5 \pm 0,3$	3,5	50274	51274	52274
0,33	7,5	16,5				50334	51334	52334
0,39	9,5	19			5,1	50394	51394	52394
0,47	9,5	19				50474	51474	52474
0,56	11	20			7,4	50564	51564	52564
0,68	11	20	31	$27,5 \pm 0,3$		50684	51684	52684
0,82	13	22,5			10,2	50824	51824	52824
1,0	13	22,5				50105	51105	52105

Table 4 U_R (d.c.) = 630 V; max. a.c. voltage = 220 V, Fig. 1

rated capacitance μF	T_{max}	H_{max}	L_{max}	P	mass g	catalogue number 2222 344		
						tol. $\pm 20\%$	tol. $\pm 10\%$	tol. $\pm 5\%$
0,010	4,5	10			0,7	60103	61103	62103
0,012	5	11			0,85	60123	61123	62123
0,015	5	11	13	$10 \pm 0,3$		60153	61153	62153
0,018	6	12			1	60183	61183	62183
0,022	6	12				60223	61223	62223
0,027	6	11,5			1,4	60273	61273	62273
0,033	6	11,5				60333	61333	62333
0,039	7	13			1,8	60393	61393	62393
0,047	7	13	17,5	$15 \pm 0,3$		60473	61473	62473
0,056	8,5	14,5			2,55	60563	61563	62563
0,068	8,5	14,5				60683	61683	62683
0,082	6,5	15,5			2,75	60823	61823	62823
0,10	6,5	15,5				60104	61104	62104
0,12	7,5	16,5			3,5	60124	61124	62124
0,15	7,5	16,5	26	$22,5 \pm 0,3$		60154	61154	62154
0,18	9,5	19			5,1	60184	61184	62184
0,22	9,5	19				60224	61224	62224
0,27	11	20			7,4	60274	61274	62274
0,33	11	20				60334	61334	62334
0,39	13	22,5			10,2	60394	61394	62394
0,47	13	22,5	31	$27,5 \pm 0,3$		60474	61474	62474

Marking

- Rated capacitance
- Rated voltage
- Tolerance on rated capacitance
- Category voltage
- Year and month of manufacture
- Manufacturer's name
- Climatic category
- Manufacturer's type designation

The capacitors are marked on the top by embossed print with a, b and c as follows:

1st line : rated capacitance in μF , tolerance and rated d.c. voltage.

2nd line : last eight digits of the catalogue number.

The package containing the capacitors is marked with a to h.

Mounting

The capacitors are for printed-wiring applications.

Ratings and characteristics

Unless otherwise specified all electrical values apply to an ambient free air temperature of $23 \pm 1^\circ\text{C}$, an atmospheric pressure of 86 to 106 kPa and a relative humidity of $50 \pm 2\%$.

Capacitance

Rated capacitance range at 1 kHz

see Tables 1 to 4

Tolerance on rated capacitance

see Tables 1 to 4

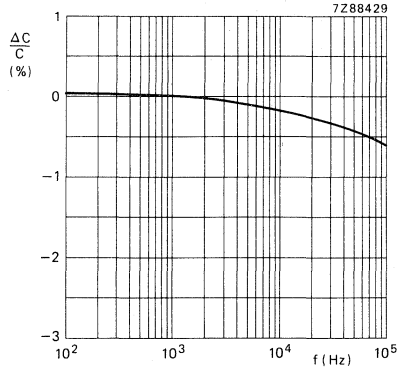

Fig. 2 Capacitance as a function of frequency; typical curve.

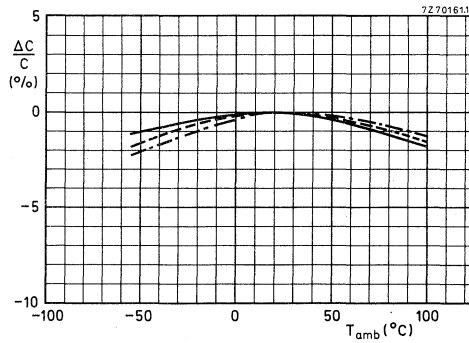

Fig. 3 Capacitance as a function of ambient free air temperature; typical curves.

— for all capacitance values, measured at 1 kHz, 1 V.

- - - for capacitance values $\leq 1 \mu\text{F}$, measured at 10 kHz, 1 V.

- · - · - for capacitance values $\leq 0,1 \mu\text{F}$, measured at 100 kHz, 0,3 V.

Voltage

Rated voltage U_R (d.c.)	See Tables 1 to 4
Category voltage U_C	$0,8 \times U_R$ (d.c.)
Maximum a.c. voltage (r.m.s. value), at 50 to 60 Hz	See Tables 1 to 4
Test voltage between terminations	$1,6 \times U_R$ (d.c.)
between interconnected terminations and case	$2 \times U_R$ (d.c.); min. 200 V

Notes

- The sum of the d.c. voltage and the peak value of the superimposed a.c. voltage must be $\leq U_R$ (d.c.).
- For waveforms other than sinusoidal the maximum permissible dissipation must not be exceeded.

Temperature

Climatic category	55/100/56
Rated temperature	85 °C
Storage temperature range	-55 to + 100 °C

Maximum pulse load

rated voltage V	maximum pulse load (V/ μ s)			
	L = 13 mm	L = 17,5 mm	L = 26 mm	L = 31 mm
100	30	13	6	4,5
250	45	18	8	7
400	70	30	13	11
630	100	45	18	15

The maximum pulse load values in the table are valid for pulse voltages equal to the rated voltage.

For lower pulse voltages the given values may be multiplied by U_R /applied voltage.

Note

If the pulse load requirement is satisfied, a check must be made to ascertain that the maximum dissipation is not exceeded.

Tangent of loss angle

capacitance	tangent of loss angle		
	1 kHz	10 kHz	100 kHz
$C_R \leq 0,1 \mu\text{F}$	$\leq 30 \times 10^{-4}$	$\leq 60 \times 10^{-4}$	$\leq 130 \times 10^{-4}$
$0,1 \mu\text{F} < C_R \leq 1 \mu\text{F}$	$\leq 30 \times 10^{-4}$	$\leq 60 \times 10^{-4}$	
$C_R > 1 \mu\text{F}$	$\leq 30 \times 10^{-4}$	$\leq 75 \times 10^{-4}$	

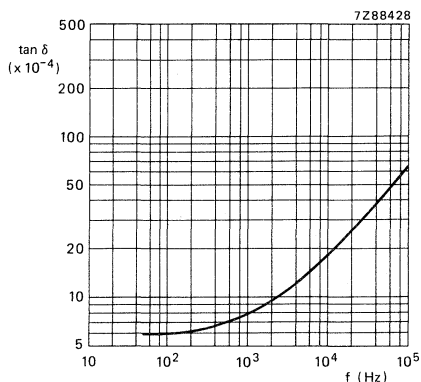
Fig. 4 Tan δ as a function of frequency, typical curve.

Insulation resistance

The insulation resistance is measured after a voltage has been applied for $1 \text{ min} \pm 5 \text{ s}$, the voltage being $100 \pm 15 \text{ V}$ for the 100 V, 250 V and 400 V versions, and $500 \pm 50 \text{ V}$ for the 630 V version, at $T_{\text{amb}} = 20 \text{ }^\circ\text{C}$.

R between terminations, for $C_R \leq 0,33 \mu\text{F}$

100 V version

$> 15\,000 \text{ M}\Omega$

250 V, 400 V, 630 V versions

$> 30\,000 \text{ M}\Omega$

RC between terminations, for $C_R > 0,33 \mu\text{F}$

100 V version

$> 5\,000 \text{ s}$

250 V, 400 V, 630 V versions

$> 10\,000 \text{ s}$

R between interconnected terminations and case (foil method)

$> 30\,000 \text{ M}\Omega$

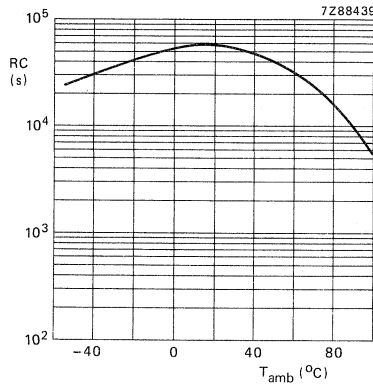

Fig. 5 RC-product as a function of ambient free air temperature; typical curve.

Maximum dissipation

Notes

In applications where voltages higher than 50 V are applied, it is recommended that the power in the capacitor be limited to 2,5 VA in case of capacitor failure.

If the requirement for the maximum dissipation is satisfied, a check must be made to ascertain that the maximum pulse load is not exceeded.

The maximum a.c. voltage has been specified for 50 to 60 Hz and at 23 °C. This voltage value must also never be exceeded at other frequencies. This permissible a.c. voltage may further be limited by the following requirements:

1. The power dissipation must not exceed the specified limit P_{max}.
2. The steepness of the a.c. voltage must not exceed the specified limit.

The power dissipated by a capacitor is a function of the voltage across the series resistance (R_s) or of the current through the series resistance and is expressed by

$$P = \frac{V_{R_s}^2}{R_s} = I^2 R_s \tag{1}$$

$$V_{R_s}^2 = \frac{R_s^2}{R_s^2 + 1/\omega^2 C^2} V_{ac}^2 \tag{2a}$$

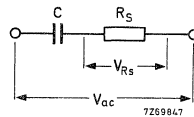

Because for these capacitors tan δ = R_sωC = < 0,1, the formula (2a) can be simplified to

$$V_{R_s}^2 = \frac{R_s^2}{1/\omega^2 C^2} V_{ac}^2 = R_s^2 \omega^2 C^2 V_{ac}^2 \tag{2b}$$

Thus $P = R_s \omega^2 C^2 V_{ac}^2 \tag{3a}$

or $P = (R_s C) C \omega^2 V_{ac}^2 \tag{3b}$

The term $R_s C$ can be found from Fig. 6, C (in farads), $\omega = 2\pi f$ and V_{ac} are assumed to be known.

The maximum permissible value of power dissipation (P_{max}), which depends on the dimensions of the capacitor and on the ambient free air temperature, can be read from Fig. 7.

Thus, when the actual power has been calculated with equation (3b), Fig. 7 gives the minimum size of capacitor which can dissipate this power.

Example of using Figs 6 and 7

A capacitor of $1 \mu F$ should be used at an a.c. voltage of 130 V, a frequency of 1 kHz and an ambient free air temperature of $50^\circ C$.

The $R_s C$ -product is $1,5 \times 10^{-7} \Omega F$ (from Fig. 6), so that the power to be dissipated is

$$\begin{aligned} P &= (R_s C) C \omega^2 V_{ac}^2 \\ &= 1,5 \cdot 10^{-7} \times 1 \cdot 10^{-6} \times (2\pi)^2 \times 10^6 \times 130^2 \\ &= 100 \text{ mW} \end{aligned}$$

For a rated voltage of 130 Vac a capacitor of the 250 V version is required at least.

Capacitor $1 \mu F/160 \text{ Vac}$ is satisfactory because of its dimensions $9,5 \text{ mm} \times 19 \text{ mm} \times 26 \text{ mm}$ and its dissipated power of 755 mW at $50^\circ C$.

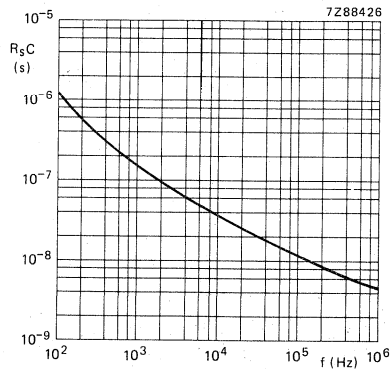

Fig. 6 Maximum product of series resistance and capacitance as a function of frequency.

curve	dimensions (mm)		
	T _{max}	H _{max}	L _{max}
1	4,5	10	13
2	5	11	13
3	6	12	13
4	5	11	17,5
5	6	11,5	17,5
6	7	13	17,5
7	8,5	14,5	17,5
8	6,5	15,5	26
9	7,5	16,5	26
10	8,5	17,5	26
11	9,5	19	26
12	11	20	31
13	13	22,5	31

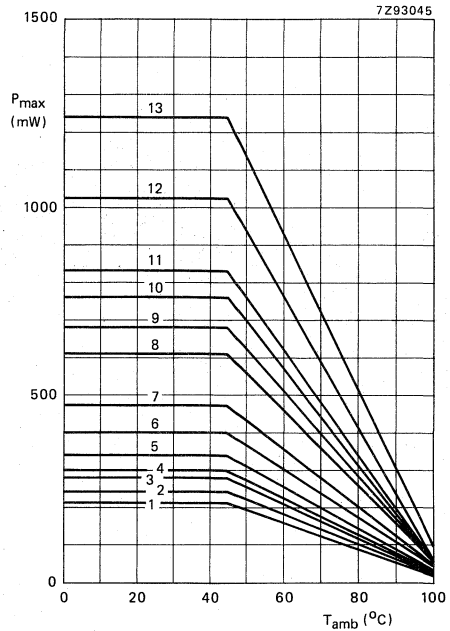

Fig. 7 Maximum dissipation as a function of ambient free air temperature.

ORDERING INFORMATION

Order the capacitors by quoting the 12-digit catalogue number as shown in Tables 1 to 4.

PACKING

The capacitors are packed in boxes, the number of capacitors per box is given in the table below.

L _{max} mm	number of capacitors per box
13, 17,5	1000
26	200
31	100

INSPECTION REQUIREMENTS

metallized polycarbonate film capacitors (MKC)

Note 1

Sub-clause numbers of tests and performance requirements refer to the Sectional Specification, IEC-publication 384-6 and GENERAL DATA of the specifications.

Note 2

In this table: D = destructive, ND = non-destructive.

clause number and test (see Note 1)	D or ND	conditions of test (see Note 1)	performance requirements 2222 341
Group A Inspection (lot-by-lot)			
Sub-group A1	ND		
4.1 Visual examination			<ul style="list-style-type: none"> – No mechanical failures – Legible marking and as specified in GENERAL DATA of the specification.
4.2 Dimensions		Gauging	<ul style="list-style-type: none"> – As specified in the Tables of the specification.
Sub-group A2	ND		
4.2.1 Voltage proof (Test A)		at $1,6 \times U_R$ (d.c.) for 1 s	<ul style="list-style-type: none"> – No breakdown or flashover.
4.2.2 Capacitance		at 1 kHz	<ul style="list-style-type: none"> – Within specified tolerance.
4.2.3 Tangent of loss angle		at 10 kHz	<ul style="list-style-type: none"> – As in GENERAL DATA of the specification.
4.2.4 Insulation resistance (Test A)		at 100 V for $U_R = 100$ V, 250 V, 400 V; at 500 V for $U_R = 630$ V, 1000 V	<ul style="list-style-type: none"> – As in GENERAL DATA of the specification.

performance requirements
2222 344

- No mechanical failures
 - Legible marking and as specified in GENERAL DATA of the specification.
 - As specified in the Tables of the specification.

 - No breakdown or flashover.
 - Within specified tolerance.
 - As in GENERAL DATA of the specification.
 - As in GENERAL DATA of the specification.
-

sub-clause number and test (see Note 1)	D or ND	conditions of test (see Note 1)	performance requirements 2222 341
Group B Inspection (periodic) 4.5 Solderability	D	Without ageing Method: 1 Solder bath: 235 °C Dwell time: 2 s Non-activated colophony flux	Good tinning as evidenced by free flowing of the solder with wetting of the terminations.
Group C Inspection (periodic) Sub-group C1A Part of sample of Sub-group C1 4.1 Dimensions (detail) 4.3.1 Initial measurements 4.3 Robustness of terminations 4.4 Resistance to soldering heat 4.4.2 Final measurements	D	Capacitance Tangent of loss angle for $C_R \leq 470 \text{ nF}$ at 100 kHz, $C_R > 470 \text{ nF}$ at 10 kHz Tensile, bending and torsion Method: 1A Solder bath: 260 °C Duration: 10 s Visual examination Capacitance Tangent of loss angle	As specified in the Tables of the specification. No visible damage. No visible damage. Legible marking. $\Delta C/C \leq 1\%$ of the value measured initially. Increase of $\tan \delta$ $\leq 0,005$ for $C_R \leq 470 \text{ nF}$, $\leq 0,003$ for $C_R > 470 \text{ nF}$, compared to values measured in 4.3.1.

performance requirements
2222 344

Good tinning as evidenced by free flowing of the solder with wetting of terminations.

As specified in the Tables of the specification.

No visible damage.

No visible damage.
Legible marking.
 $\Delta C/C \leq 1\%$ of the value measured initially.
Increase of $\tan \delta$
 $\leq 0,005$ for $C_R \leq 470$ nF,
 $\leq 0,003$ for $C_R > 470$ nF,
compared to values measured in 4.3.1.

sub-clause number and (see Note 1)	D or ND	conditions of test (see Note 1)	performance requirements 2222 341
<p>Sub-group C1B Other part of sample of Sub-group C1</p> <p>4.6.1 Initial measurements</p> <p>4.6 Rapid change of temperature</p> <p>4.7 Vibration</p> <p>4.7.2 Final inspection</p> <p>4.9 Shock</p> <p>4.9.3 Final measurements</p>	D	<p>Capacitance Tangent of loss angle for $C_R \leq 470$ nF at 100 kHz, $C_R > 470$ nF at 10 kHz</p> <p>θ A = lower cat. temp. θ B = upper cat. temp. 5 cycles, duration $t = 30$ min. Visual examination</p> <p>Method of mounting see Note below. Procedure B4. Frequency range: 10 to 55 Hz Amplitude: 0,75 mm or acceleration: 98 m/s² (whichever is the less severe). Total duration: 6 h</p> <p>Visual examination</p> <p>Method of mounting see Note below. Pulse shape: half sine Acceleration: 490 m/s² Duration of pulse: 11 ms</p> <p>Visual examination Capacitance</p> <p>Tangent of loss angle</p> <p>Insulation resistance</p>	<p>No visible damage.</p> <p>No visible damage.</p> <p>No visible damage. $\Delta C/C \leq 2,5\%$ of the value measured in 4.6.1. Increase of $\tan \delta$ $\leq 0,005$ for $C_R \leq 470$ nF, $\leq 0,003$ for $C_R > 470$ nF compared to values measured in 4.6.1. As in GENERAL DATA of the specification.</p>

Note

The capacitor shall be mechanically fixed by the leads and the stand-off pips (ridges) shall be in good contact with the printed-wiring board, also the body of capacitors with a mass > 6 g shall be clamped to the printed-wiring board.

performance requirements
2222 344

No visible damage.

No visible damage.

No visible damage.

$\Delta C/C \leq 2,5\%$ of the value
measured in 4.6.1.

Increase of $\tan \delta$

$\leq 0,005$ for $C_R \leq 470$ nF,

$\leq 0,003$ for $C_R > 470$ nF

compared to values
measured in 4.6.1.

As in GENERAL DATA of
the specification.

sub-clause number and test (see Note 1)	D or ND	conditions of test (see Note 1)	performance requirements 2222 341
<p>Sub-group C1 Combined sample of specimens of Sub-groups C1A and C1B 4.10 Climatic sequence 4.10.2 Dry heat 4.10.3 Damp heat cyclic, Test Db, first cycle 4.10.4 Cold 4.10.6 Damp heat cyclic, Test Db, remaining cycles 4.10.6.2 Final measurements</p>	D	<p>Temperature: upper category temperature Duration: 16 h Temperature: lower category temperature Duration: 2 h Visual examination Capacitance Tangent of loss angle Insulation resistance</p>	<p>No visible damage. Legible marking. $\Delta C/C \leq 5\%$ of value measured in 4.4.2 or 4.9.3. Increase of $\tan \delta$ $\leq 0,007$ for $C_R \leq 470$ nF, $\leq 0,005$ for $C_R > 470$ nF compared to values measured in 4.3.1 or 4.6.1. $\geq 50\%$ of values in GENERAL DATA of the specification.</p>

performance requirements
2222 344

No visible damage.

Legible marking.

$\Delta C/C \leq 3\%$ of value
measured in 4.4.2 or 4.9.3.

Increase of $\tan \delta$

$\leq 0,007$ for $C_R \leq 470$ nF,

$\leq 0,005$ for $C_R > 470$ nF

compared to values

measured in 4.3.1 or 4.6.1.

$\geq 50\%$ of values in GENERAL

DATA in the specification.

sub-clause number and test (see Note 1)	D or ND	conditions of test (see Note 1)	performance requirements 2222 341
Sub-group C2 4.11 Damp heat steady state 4.11.1 Initial measurements 4.11.3 Final measurements	D	Capacitance Tangent of loss angle for $C_R \leq 470 \text{ nF}$ at 100 kHz, $C_R > 470 \text{ nF}$ at 10 kHz Visual examination Capacitance Tangent of loss angle Insulation resistance	No visible damage. Legible marking. $\Delta C/C \leq 3\%$ of the value measured in 4.11.1. Increase of $\tan \delta$ $\leq 0,007$ for $C_R \leq 470 \text{ nF}$, $\leq 0,005$ for $C_R > 470 \text{ nF}$ compared to values measured in 4.11.1. $\geq 50\%$ of values in GENERAL DATA of the specification.
Sub-group C3 4.12 Endurance 4.12.1 Initial measurements 4.12.5 Final measurements	D	Duration: 2000 h; $1,25 U_R$ (d.c.) at 85 °C, $1,25 U_C$ at 100 °C Capacitance Tangent of loss angle for $C_R \leq 470 \text{ nF}$ at 100 kHz, $C_R > 470 \text{ nF}$ at 10 kHz Visual examination Capacitance Tangent of loss angle Insulation resistance	No visible damage. Legible marking. $\Delta C/C \leq 3\%$ of value measured in 4.12.1. Increase of $\tan \delta$ $\leq 0,005$ for $C_R \leq 470 \text{ nF}$, $\leq 0,003$ for $C_R > 470 \text{ nF}$ compared to values measured in 4.12.1. $\geq 50\%$ of values in GENERAL DATA of the specification.

performance requirements
2222 344

No visible damage.

Legible marking.

$\Delta C/C \leq 3\%$ of the value
measured in 4.11.1.

Increase of $\tan \delta$

$\leq 0,007$ for $C_R \leq 470$ nF,

$\leq 0,005$ for $C_R > 470$ nF

compared to values

measured in 4.11.1.

$\geq 50\%$ of values in GENERAL

DATA of the specification.

No visible damage.

Legible marking.

$\Delta C/C \leq 3\%$ of value
measured in 4.12.1.

Increase of $\tan \delta$

$\leq 0,005$ for $C_R \leq 470$ nF,

$\leq 0,003$ for $C_R > 470$ nF

compared to values

measured in 4.12.1.

$\geq 50\%$ of values in GENERAL

DATA of the specification.

sub-clause number and test (see Note 1)	D or ND	conditions of test (see Note 1)	performance requirements 2222 341
Sub-group C4	D		
4.13 Charge and discharge		10 000 cycles (50 c/s) charge to U_R half sine wave Duration: 5 ms, discharge $R = \frac{U_R}{C_R \cdot 5 \left(\frac{dU}{dt}\right) R}$	
4.13.1 Initial measurements		with a min. of 2,2 Ω Capacitance Tangent of loss angle for $C_R \leq 470 \text{ nF}$ at 100 kHz, $C_R > 470 \text{ nF}$ at 10 kHz	
4.13.3 Final measurements		Capacitance Tangent of loss angle Insulation resistance	$\Delta C/C \leq 2\%$ of value measured in 4.13.1. Increase of $\tan \delta$ $\leq 0,005$ for $C_R \leq 470 \text{ nF}$, $\leq 0,003$ for $C_R > 470 \text{ nF}$. $\geq 50\%$ of values in GENERAL DATA of the specification.

performance requirements
2222 344

$\Delta C/C \leq 2\%$ of value
measured in 4.13.1.

Increase of $\tan \delta$

$\leq 0,005$ for $C_R \leq 470$ nF,

$\leq 0,003$ for $C_R > 470$ nF.

$\geq 50\%$ of values in GENERAL
DATA of the specification.

additional test	D or ND	conditions of test	performance requirements 2222 341
<p>Sub-group ADD1</p> <p>A.1 Heat storage</p> <p>A.1.1 Initial measurements</p> <p>A.1.2 Final measurements</p>	D	<p>Duration: 2000 h Temperature: upper category temperature</p> <p>Capacitance Tangent of loss angle for $C_R \leq 470$ nF at 100 kHz, $C_R > 470$ nF at 10 kHz</p> <p>Capacitance</p> <p>Tangent of loss angle</p> <p>Insulation resistance</p>	<p>$\Delta C/C \leq 5\%$ of value measured in A.1.1. Increase of $\tan \delta$ $\leq 0,005$ for $C_R \leq 470$ nF, $\leq 0,003$ for $C_R > 470$ nF compared to values measured in A.1.1. As in GENERAL DATA of the specification.</p>
<p>Sub-group ADD2</p> <p>A.2 Endurance for capacitors with max. a.c. voltage ≥ 200 V (r.m.s.)</p> <p>A.2.1 Initial measurements</p> <p>A.2.2 Final measurements</p>		<p>Duration: 1000 h Temperature: 85 °C Voltage: 1,25 x max. a.c. voltage (r.m.s. value), 50 Hz</p> <p>Capacitance Tangent of loss angle for $C_R \leq 470$ nF at 100 kHz, $C_R > 470$ nF at 10 kHz</p> <p>Capacitance</p> <p>Tangent of loss angle</p> <p>Insulation resistance</p>	<p>$\Delta C/C \leq 3\%$ of value measured in A.2.1. Increase of $\tan \delta$ $\leq 0,005$ for $C_R \leq 470$ nF, $\leq 0,003$ for $C_R > 470$ nF compared to values measured in A.2.1. As in GENERAL DATA of the specification.</p>

performance requirements
2222 344

$\Delta C/C \leq 3\%$ of value
measured in A.1.1.
Increase of $\tan \delta$
 $\leq 0,005$ for $C_R \leq 470$ nF,
 $\leq 0,003$ for $C_R > 470$ nF
compared to values
measured in A.1.1.
As in GENERAL DATA of
the specification.

$\Delta C/C \leq 3\%$ of value
measured in A.2.1.
Increase of $\tan \delta$
 $\leq 0,005$ for $C_R \leq 470$ nF,
 $\leq 0,003$ for $C_R > 470$ nF
compared to values
measured in A.2.1.
As in GENERAL DATA of
the specification.

additional test	D or ND	conditions of test	performance requirements 2222 341
<p>Sub-group ADD3 A.3 Solvent resistance, Mil STD-202F, method 215 B</p> <p>A.3.1 Initial measurements</p> <p>A.3.2 Final measurements</p>		<p>GROUP 1: De-ionized water, followed by mixture of isopropyl alcohol and mineral spirits</p> <p>GROUP 2: 1-1-1-Trichloroethane</p> <p>GROUP 3: Azeotropic mixture of trichlorotrifluoroethane and methylene chloride Temperature: 25 °C</p> <p>Capacitance Tangent of loss angle for $C_R \leq 470$ nF at 100 kHz, $C_R > 470$ nF at 10 kHz</p> <p>Capacitance</p> <p>Tangent of loss angle</p> <p>Insulation resistance</p>	<p>$\Delta C/C \leq 1\%$ of value measured in A.3.1. Increase of $\tan \delta$ $\leq 0,005$ for $C_R \leq 470$ nF, $\leq 0,003$ for $C_R > 470$ nF compared to values measured in A.3.1. $\geq 50\%$ of values in GENERAL DATA of the specification.</p>
<p>Sub-group ADD4 A.4 Detergent resistance</p> <p>A.4.1 Initial measurements</p> <p>A.4.2 Final measurements</p>		<p>Density 20g/l dishwasher detergent Temperature 70 °C, during 3 min. Followed by rinsing in clear water for 1 min. Recovery time > 2 h.</p> <p>Capacitance Tangent of loss angle for $C_R \leq 470$ nF at 100 kHz, $C_R > 470$ nF at 10 kHz</p> <p>Capacitance</p> <p>Tangent of loss angle</p> <p>Insulation resistance</p>	<p>$\Delta C/C \leq 1\%$ of value measured in A.4.1. Increase of $\tan \delta$ $\leq 0,005$ for $C_R \leq 470$ nF, $\leq 0,003$ for $C_R > 470$ nF compared to values measured in A.4.1. $\geq 50\%$ of values in GENERAL DATA of the specification.</p>

performance requirements
2222 344

$\Delta C/C \leq 1\%$ of value
measured in A.3.1.
Increase of $\tan \delta$
 $\leq 0,005$ for $C_R \leq 470$ nF,
 $\leq 0,003$ for $C_R > 470$ nF
compared to values
measured in A.3.1.
 $\geq 50\%$ of values in GENERAL
DATA of the specification.

$\Delta C/C \leq 1\%$ of value
measured in A.4.1.
Increase of $\tan \delta$
 $\leq 0,005$ for $C_R \leq 470$ nF,
 $\leq 0,003$ for $C_R > 470$ nF
compared to values
measured in A.4.1.
 $\geq 50\%$ of values in GENERAL
DATA of the specification.

additional test	D or ND	conditions of test	performance requirements 2222 341
<p>Sub-group ADD5</p> <p>A.5 Resistance to soldering heat with pre-heating</p> <p>A.5.1 Initial measurements</p> <p>A.5.2 Final measurements</p>	D	<p>Capacitors mounted on a 1,6 mm board with non-plated holes</p> <p>Body temp.: 80 °C</p> <p>Bath temp.: 260 °C</p> <p>Dwell time: 5 s.</p> <p>Capacitance</p> <p>Tangent of loss angle for $C_R \leq 470$ nF at 100 kHz, $C_R > 470$ nF at 10 kHz</p> <p>Capacitance</p> <p>Tangent of loss angle</p>	<p>$\Delta C/C \leq 2\%$ for $C \leq 10$ nF, $\leq 1\%$ for $C > 10$ nF of value measured in A.5.1.</p> <p>Increase of $\tan \delta$</p> <p>$\leq 0,005$ for $C_R \leq 470$ nF, $\leq 0,003$ for $C_R > 470$ nF compared to values measured in A.5.1.</p>
<p>Sub-group ADD6</p> <p>A.6.1 Needle flame test, IEC 695-2-2</p>	D	<p>Bore of gas jet: ϕ 0,5 mm.</p> <p>Fuel: butane.</p> <p>Test duration: 20 s</p> <p>One flame application.</p>	<p>After removing the test flame from the capacitor, the capacitor must not continue to burn for more than 15 s, no burning particles must drop from the sample.</p>

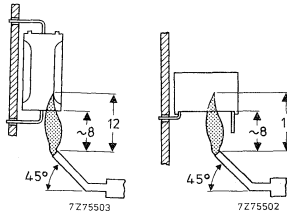

performance requirements
2222 344

$\Delta C/C \leq 1\%$ of value measured
in A.5.1.

Increase of $\tan \delta$
 $\leq 0,005$ for $C_R \leq 470$ nF,
 $\leq 0,003$ for $C_R > 470$ nF
compared to values
measured in A.5.1.

After removing the test flame
from the capacitor, the
capacitor must not continue
to burn for more than 15 s,
no burning particles must drop
from the sample.

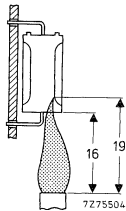
additional test	D or ND	conditions of test	performance requirements 2222 341
A.6.2 Needle flame test, UL 1414		<p>Bore of gas jet: ϕ 10 mm. Fuel: natural gas. Test duration: 3 x 15 s. Time interval between each flame application: 15 s.</p> 	Extinguishing time \leq 15 s after the first and second flame application, \leq 60 s after the third flame application.

Inspection requirements

MKC

performance requirements
2222 344

Not applicable.

POLYSTYRENE FILM/FOIL CAPACITORS
(KS)

POLYSTYRENE FILM/FOIL CAPACITORS

KS axial sleeved type

- Supplied on bandoliers on reel or loose in boxes

QUICK REFERENCE DATA

Rated capacitance range	51 to 39 000 pF
Tolerance on rated capacitance	± 5% (E24-series) ± 2% (E24, E48-series) ± 1% (E24, E48, E96-series)
Rated voltage U_R (d.c.)	63 V, 160 V, 250 V, 630 V
Climatic category	
63 V version	40/070/21
160 V, 250 V, 630 V versions	40/085/21
Rated temperature	
63 V version	70 °C
160 V, 250 V, 630 V versions	85 °C
Related specification	IEC 384-7
Stability class	2

SURVEY OF STYLES

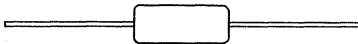

Style 2222 424 to 427 ;
See Tables 1 to 4.

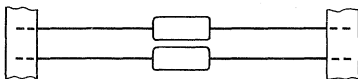

Style 2222 428 to 431 ;
See Tables 1 to 4.

APPLICATION

For use in circuits where close tolerance, reliability and low losses are of prime importance, e.g. tuned circuits, filter networks, etc.

DESCRIPTION

The capacitors consist of a low-inductance wound cell of metal foil and a polystyrene film. The cell is covered with a green plastic sleeve. The axial leads are of solder-coated wire.

GENERAL DATA

Dimensions in mm

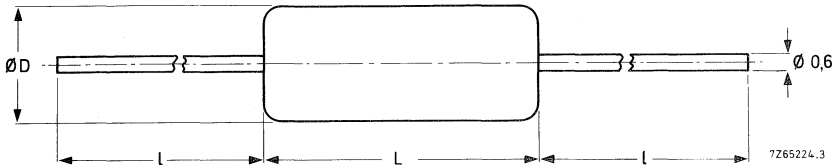

Fig. 1.

Table 1 U_R (d.c.) = 63 V; max. a.c. voltage = 25 V; Fig. 1

rated capacitance (E24-series, tol. $\pm 5\%$)* pF	D_{max}	L_{max}	l_{min}	approx. mass g	catalogue number							
					on bandoliers on reel	in box						
2 000	3,8	11	30	0,3	2222 428 62002	2222 424 22002						
2 200					62202	22202						
2 400					62402	22402						
2 700	4,0			11	30	0,4	62702	22702				
3 000							63002	23002				
3 300							63302	23302				
3 600							63602	23602				
3 900	4,5					11	30	0,5	63902	23902		
4 300									64302	24302		
4 700									64702	24702		
5 100	5,0							15	28	0,6	65102	25102
5 600		65602	25602									
6 200		66202	26202									
6 800		66802	26802									
7 500	5,5	15	28	0,7	67502					27502		
8 200					68202					28202		
9 100					69102					29102		
10 000	6,0			15	28					0,8	61003	21003
11 000						61103	21103					
12 000						61203	21203					
13 000						61303	21303					
15 000	6,5					15	28	0,9	61503	21503		
16 000									61603	21603		
18 000									61803	21803		
20 000	7,0							15	28	1,1	62003	22003
22 000		62203	22203									
24 000		62403	22403									
27 000		62703	22703									
30 000	7,5	15	28	1,3	63003					23003		
33 000					63303					23303		
36 000					63603					23603		
39 000	8,0			15	28					1,5	63903	23903

* The capacitance values quoted are also available with a tolerance $\pm 1\%$ or $\pm 2\%$. Besides the values of the E24-series as quoted, intermediate values of the E48-series (with a tolerance $\pm 1\%$ or $\pm 2\%$) and of the E96-series (with a tolerance $\pm 1\%$) are available.

Table 2 U_R (d.c.) = 160 V; max. a.c. voltage = 63 V; Fig. 1

rated capacitance (E24-series, tol. $\pm 5\%$)* pF	D_{\max}	L_{\max}	l_{\min}	approx. mass g	catalogue number								
					on bandoliers on reel	in box							
1 100	3,8	11	30	0,3	2222 429 61102	2222 425 21102							
1 200					61202	21202							
1 300	61302				21302								
1 500	4,0			11	30	61502	21502						
1 600						61602	21602						
1 800	4,5					11	30	61802	21802				
2 000								62002	22002				
2 200	4,5							11	30	62202	22202		
2 400										62402	22402		
2 700	5,0									11	30	62702	22702
3 000		63002	23002										
3 300	5,0	11	30									63302	23302
3 600												63602	23602
3 900	5,5			15	28							63902	23902
4 300												64302	24302
4 700	6,0					15	28					64702	24702
5 100												65102	25102
5 600	6,5							15	28			65602	25602
6 200												66202	26202
6 800	7,0									15	28	66802	26802
7 500												67502	27502
8 200	7,0	15	28									68202	28202
9 100												69102	29102
10 000	7,0			15	28							61003	21003
11 000												61103	21103
12 000	7,0					15	28					61203	21203
13 000												61303	21303
15 000	7,0							15	28			61503	21503
16 000												61603	21603

* The capacitance values quoted are also available with a tolerance $\pm 1\%$ or $\pm 2\%$.

Besides the values of the E24-series as quoted, intermediate values of the E48-series (with a tolerance $\pm 1\%$ or $\pm 2\%$) and of the E96-series (with a tolerance $\pm 1\%$) are available.

Table 3 U_R (d.c.) = 250 V; max. a.c. voltage = 125 V; Fig. 1

rated capacitance (E24-series, tol. $\pm 5\%$)* pF	D_{max}	L_{max}	l_{min}	approx. mass g	catalogue number		
					on bandoliers on reel	in box	
560	3,8	11	30	0,3	2222 430 65601	2222 426 25601	
620					66201	26201	
680					66801	26801	
750	4,0			0,4	67501	27501	
820					68201	28201	
910					69101	29101	
1 000	4,5			0,5	61002	21002	
1 100					61102	21102	
1 200					61202	21202	
1 300	5,0			15	28	61302	21302
1 500						61502	21502
1 600		61602	21602				
1 800		61802	21802				
2 000		62002	22002				
2 200		62202	22202				
2 400		62402	22402				
2 700		62702	22702				
3 000		63002	23002				
3 300		63302	23302				
3 600		63602	23602				
3 900	5,5	0,7	63902	23902			
4 300			64302	24302			
4 700			64702	24702			
5 100	6,0	0,8	65102	25102			
5 600			65602	25602			
6 200			66202	26202			
6 800	6,5	0,9	66802	26802			
7 500			67502	27502			
8 200			68202	28202			
9 100	7,0	1,1	69102	29102			
10 000			61003	21003			
11 000			61103	21103			

* The capacitance values quoted are also available with a tolerance $\pm 1\%$ or $\pm 2\%$. Besides the values of the E24-series as quoted, intermediate values of the E48-series (with a tolerance $\pm 1\%$ or $\pm 2\%$) and of the E96-series (with a tolerance $\pm 1\%$) are available.

Table 4 U_R (d.c.) = 630 V; max. a.c. voltage = 250 V; Fig. 1

rated capacitance (E24-series, tol. $\pm 5\%$)* pF	D_{max}	L_{max}	l_{min}	approx. mass g	catalogue number					
					on bandoliers on reel	in box				
51	3,8	11	30	0,2	2222 431 65109	2222 427 25109				
56					65609	25609				
62					66209	26209				
68					66809	26809				
75					67509	27509				
82					68209	28209				
91					69109	29109				
100					61001	21001				
110					61101	21101				
120					61201	21201				
130					61301	21301				
150					61501	21501				
160				61601	21601					
180				61801	21801					
200				62001	22001					
220				62201	22201					
240				62401	22401					
270				62701	22701					
300				63001	23001					
330				4,0	15	28	0,3	63301	23301	
360								63601	23601	
390								63901	23901	
430								64301	24301	
470								64701	24701	
510	65101	25101								
560	4,5	15	28	0,4	65601	25601				
620					66201	26201				
680					66801	26801				
750					67501	27501				
820					68201	28201				
910					69101	29101				
1 000	5,0	15	28	0,5	61002	21002				
1 100					61102	21102				
1 200					61202	21202				
1 300					61302	21302				
1 500					61502	21502				
1 600					61602	21602				
1 800	5,5	15	28	0,6	61802	21802				
2 000					62002	22002				
2 200					62202	22202				
2 400					62402	22402				
2 700					6,0	15	28	0,7	62702	22702
									62702	22702
				0,8						
				0,9						
				1,1						

* The capacitance values quoted are also available with a tolerance $\pm 1\%$ or $\pm 2\%$. Besides the values of the E24-series as quoted, intermediate values of the E48-series (with a tolerance $\pm 1\%$ or $\pm 2\%$) and of the E96-series (with a tolerance $\pm 1\%$) are available.

Table 4 (continued) U_R (d.c.) = 630 V; max. a.c. voltage = 250 V; Fig. 1

rated capacitance (E24-series, tol. $\pm 5\%$)* pF	D_{max}	L_{max}	l_{min}	approx. mass g	catalogue number	
					on bandoliers on reel	in box
3 000	6,5	15	28	1,1	2222 431 63002	2222 427 23002
3 300						
3 600	7,0			1,4	63302	23302
3 900						
4 300	7,5			1,7	63602	23602
4 700						
5 100	8,0			2,0	63902	23902
5 600						
					64302	24302
					64702	24702
					65102	25102
					65602	25602

Marking

The capacitors are marked in ink as follows:

1st line : rated capacitance in pF or nF;

2nd line: tolerance code (F = $\pm 1\%$, G = $\pm 2\%$, J = $\pm 5\%$) and rated voltage (d.c.);

3rd line : production date code (according to IEC 62, clause 5) and code for dielectric materials
(KS = polystyrene film/foil).

Mounting

The capacitors are suited for horizontal or vertical mounting on printed-wiring boards and for point-to-point wiring.

The capacitors packed on bandoliers are for mounting with automatic insertion machines.

When soldering the capacitors, the body temperature shall not exceed 100 °C.

Note: Capacitors mounted vertically on a board without plated-through holes; bodies rest on the board; board thickness: 1,6 mm, hole diameter: 0,8 mm.

Bath temperature 250 °C, dip-solder time 7,5 s

bath temperature 260 °C, dip-solder time 5 s.

Capacitors mounted horizontally on a board with plated-through holes; bodies at least 1 mm from the board.

Bath temperature 260 °C, dip-solder time 5 s.

* The capacitance values quoted are also available with a tolerance $\pm 1\%$ or $\pm 2\%$.

Besides the values of the E24-series as quoted, intermediate values of the E48-series (with a tolerance $\pm 1\%$ or $\pm 2\%$) and of the E96-series (with a tolerance $\pm 1\%$) are available.

Ratings and characteristics

Unless otherwise specified all electrical values apply to an ambient free air temperature of $23 \pm 1 \text{ }^\circ\text{C}$, an atmospheric pressure of 86 to 106 kPa and a relative humidity of $50 \pm 2\%$.

Capacitance

Rated capacitance range

at 1 MHz ($C_R \leq 1000 \text{ pF}$)

at 1 kHz ($C_R > 1000 \text{ pF}$)

Tolerance on rated capacitance

Temperature coefficient

Frequency dependence between 100 Hz and 1 MHz

see Tables 1 to 4

$\pm 5\%$, $\pm 2\%$ and $\pm 1\%$ or 1 pF whichever is greater

$-(125 \pm 60) \cdot 10^{-6}/\text{K}$

none

Voltage

Rated voltage U_R (d.c.)

Category voltage U_C

Test voltage

between terminations

between interconnected terminations and case

Maximum a.c. voltage (r.m.s. value) at 50 to 60 Hz

see Tables 1 to 4

U_R (d.c.)

$2 \times U_R$ (d.c.)

$2 \times U_R$ (d.c.); min. 400 V

see Tables 1 to 4

Notes

- The sum of the d.c. voltage and the peak value of the superimposed a.c. voltage must be $\leq U_R$ (d.c.)
- For other than sinusoidal waveforms, the maximum permissible dissipation must not exceeded.

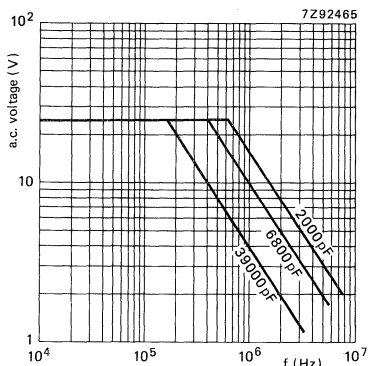

Fig. 2 Maximum a.c. voltage (r.m.s. value) as a function of frequency at $T_{amb} \leq 55 \text{ }^\circ\text{C}$, for $U_R = 63 \text{ V}$.

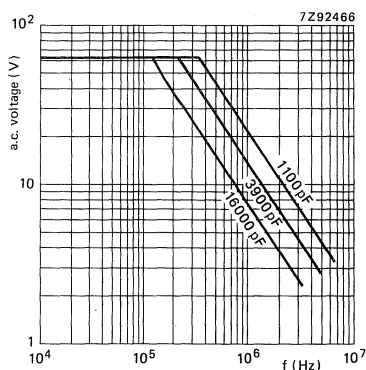

Fig. 3 Maximum a.c. voltage (r.m.s. value) as a function of frequency at $T_{amb} \leq 70 \text{ }^\circ\text{C}$, for $U_R = 160 \text{ V}$.

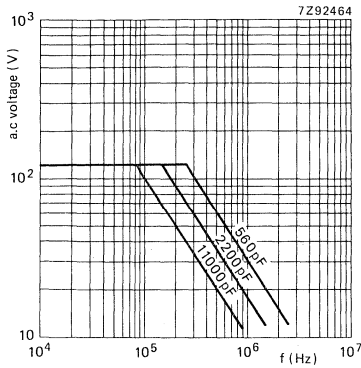

Fig. 4 Maximum a.c. voltage (r.m.s. value) as a function of frequency at $T_{amb} \leq 70^\circ C$, for $U_R = 250 V$.

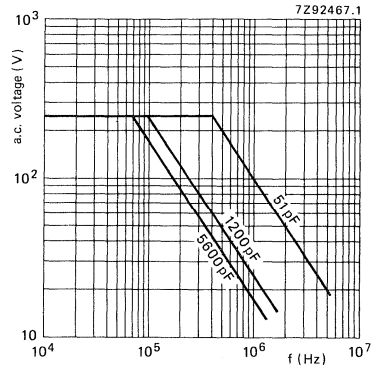

Fig. 5 Maximum a.c. voltage (r.m.s. value) as a function of frequency at $T_{amb} \leq 70^\circ C$, for $U_R = 630 V$.

Temperature

Climatic category

- 63 V version 40/070/21
- 160 V, 250 V, 630 V versions 40/085/21

Rated temperature

- 63 V version 70 °C
- 160 V, 250 V, 630 V versions 85 °C

Storage temperature range

- 63 V version -40 to + 70 °C
- 160 V, 250 V, 630 V versions -40 to + 85 °C

Tangent of loss angle

Table 5

capacitance	tangent of loss angle		
	at 1 kHz	at 100 kHz	at 1 MHz
$C_R \leq 1000 \text{ pF}$	$\leq 5 \times 10^{-4}$		$\leq 10 \times 10^{-4}$
$1000 \text{ pF} < C_R \leq 10\,000 \text{ pF}$	$\leq 5 \times 10^{-4}$	$\leq 10 \times 10^{-4}$	
$10\,000 \text{ pF} < C_R \leq 20\,000 \text{ pF}$	$\leq 5 \times 10^{-4}$	$\leq 15 \times 10^{-4}$	
$C_R > 20\,000 \text{ pF}$	$\leq 5 \times 10^{-4}$	$\leq 25 \times 10^{-4}$	

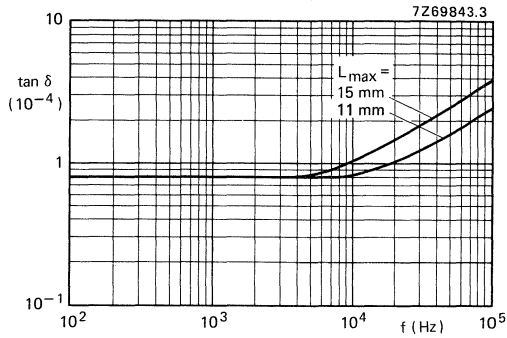

Fig. 6 $\tan \delta$ as a function of frequency; typical curves.

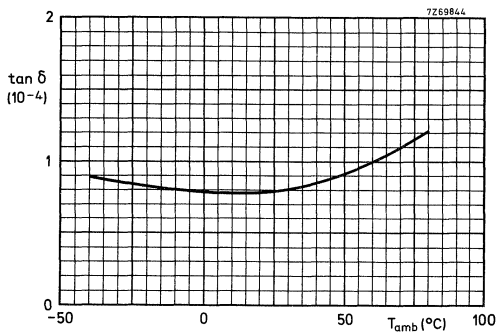

Fig. 7 $\tan \delta$ as a function of ambient free air temperature; typical curve.

Insulation resistance at $T_{amb} = 20\text{ }^{\circ}\text{C}$

The insulation resistance is measured after a voltage has been applied for $1\text{ min} \pm 5\text{ s}$, the voltage being $10 \pm 1\text{ V}$ for the 63 V version, $100 \pm 15\text{ V}$ for the 160 V and 250 V versions, and $500 \pm 50\text{ V}$ for the 630 V version.

- R between terminations $> 100\ 000\ \text{M}\Omega$
- R between interconnected terminations and case $> 100\ 000\ \text{M}\Omega$

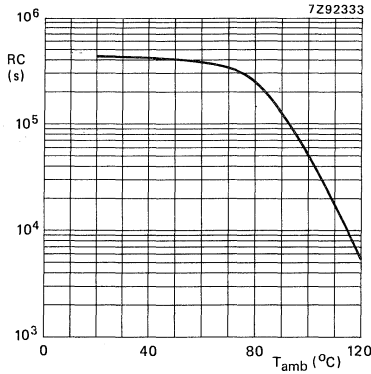

Fig. 8 RC-product as a function of ambient free air temperature; typical curve.

Inductance $\leq 10\ \text{nH/cm}$ lead and capacitor length

Maximum dissipation

The maximum a.c. voltage, which has been specified at 50 to 60 Hz must also never be exceeded at other frequencies.* Moreover this voltage may further be limited by the maximum dissipation (P_{max}).

For a capacitor used with a sinusoidal voltage, the power dissipation is expressed by:

$$P = V_{rms} I_{rms} \cos \varphi. \tag{1}$$

As $I_{rms} = \omega C V_{rms}$, and $\cos \varphi \approx \tan \delta$, equation (1) can be rewritten as:

$$P = V_{rms}^2 \omega C \tan \delta = V_{rms}^2 2\pi f C \tan \delta. \tag{2}$$

For capacitors of styles 2222 424 to 2222 431 $\tan \delta$ is about proportional to the frequency, thus:

$$\tan \delta = \frac{f}{10^5} \tan \delta_{ref}. \tag{3}$$

$\tan \delta_{ref}$ is the maximum $\tan \delta$ at 100 kHz value given under Ratings and characteristics.

Substituting equation (3) in equation (2) gives:

$$P = 2\pi \cdot 10^{-5} V_{rms}^2 f^2 C \tan \delta_{ref}. \tag{4}$$

The maximum dissipation (P_{max}), which depends on the dimensions of the capacitor and on the ambient free air temperature, can be found from Fig. 9.

* At $T_{amb} \leq 70\text{ }^{\circ}\text{C}$ ($\leq 55\text{ }^{\circ}\text{C}$ for 63 V version) the maximum permissible sinusoidal voltage can be found in Figs 2 to 5.

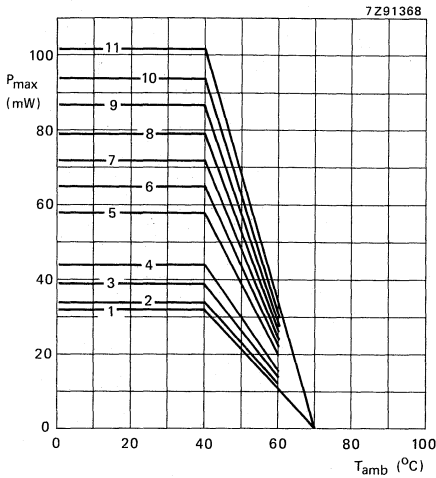

Fig. 9a Maximum dissipation as a function of ambient free air temperature, for $U_R = 63$ V.

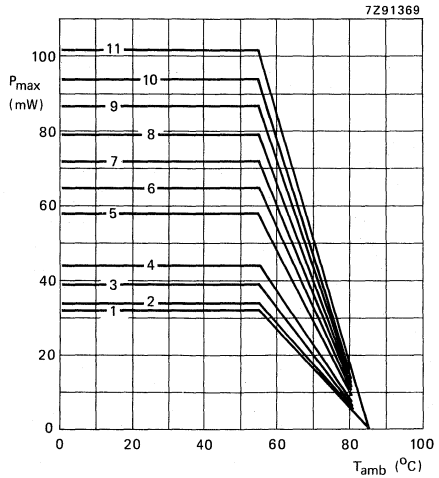

Fig. 9b Maximum dissipation as a function of ambient free air temperature, for $U_R = 160$ V, 250 V and 630 V.

Table 6

curve	dimensions (mm)	
	D_{max}	L_{max}
1	3,8	11,0
2	4,0	11,0
3	4,5	11,0
4	5,0	11,0
5	5,0	15,0
6	5,5	15,0

curve	dimensions (mm)	
	D_{max}	L_{max}
7	6,0	15,0
8	6,5	15,0
9	7,0	15,0
10	7,5	15,0
11	8,0	15,0

ORDERING INFORMATION

Order the capacitors by quoting the 12-digit catalogue number.

Composition of the catalogue number (see Tables 1 to 4).

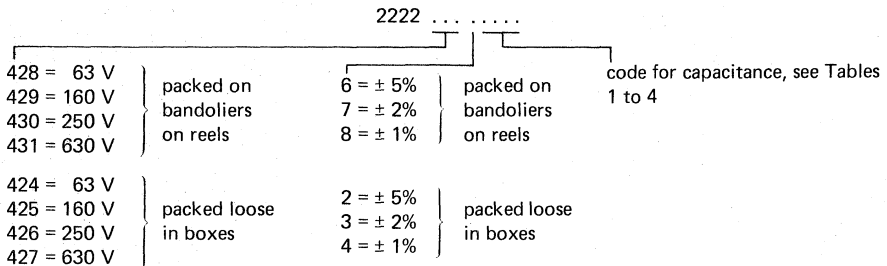

PACKING

The capacitors are supplied on bandoliers on reels or loose in cardboard boxes.

Packing in cardboard boxes

Table 7

capacitance values (pF) of				number of capacitors per box
63 V version	160 V version	250 V version	630 V version	
2 000– 3 900	1 100– 1 800	560– 1 000	51– 430	400
4 300– 5 600	2 000– 2 700	1 100– 1 500	470– 680	300
6 200– 6 800	3 000– 3 900	1 600– 2 200	750–1 000	250
			1 100–1 200	200
7 500–10 000	4 300– 6 200	2 400– 4 300	1 300–1 500	300
11 000–20 000	6 800–10 000	4 700– 6 200	1 600–2 700	250
22 000–24 000	11 000–13 000	6 800– 7 500	3 000–3 300	200
27 000–39 000	15 000–16 000	8 200–11 000	3 600–5 600	150

Packing on bandoliers on reels

Dimensions in mm

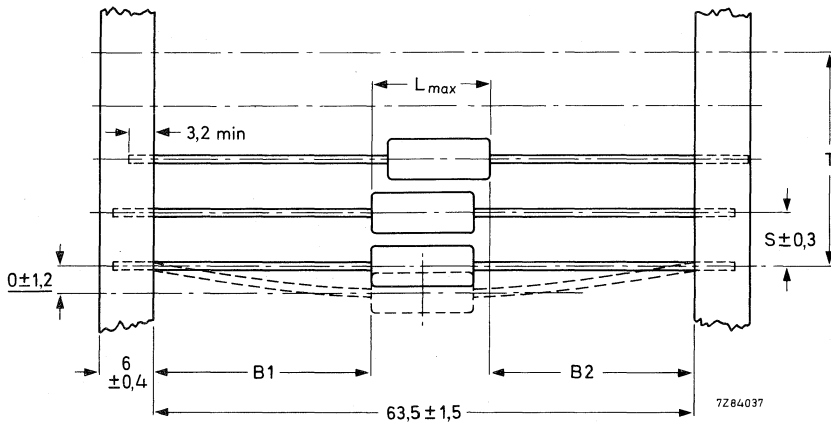

Fig. 10 Capacitors on bandoliers; for dimensions S and T, see Table 8
|B1 - B2| = max. 1,4 mm; for dimension L_{max}, see Tables 1 to 4.

Table 8

capacitance values (pF) of				S	T for number (n) of capacitors	
63 V version	160 V version	250 V version	630 V version		n < 50	50 < n < 100
2 000– 5 600	1 100– 2 700	560– 1 500	51– 680	5	5(n-1) ± 2	5(n-1) ± 4
6 200–39 000	3 000–16 000	1 600–11 000	750–5 600	10	10(n-1) ± 2	10(n-1) ± 4

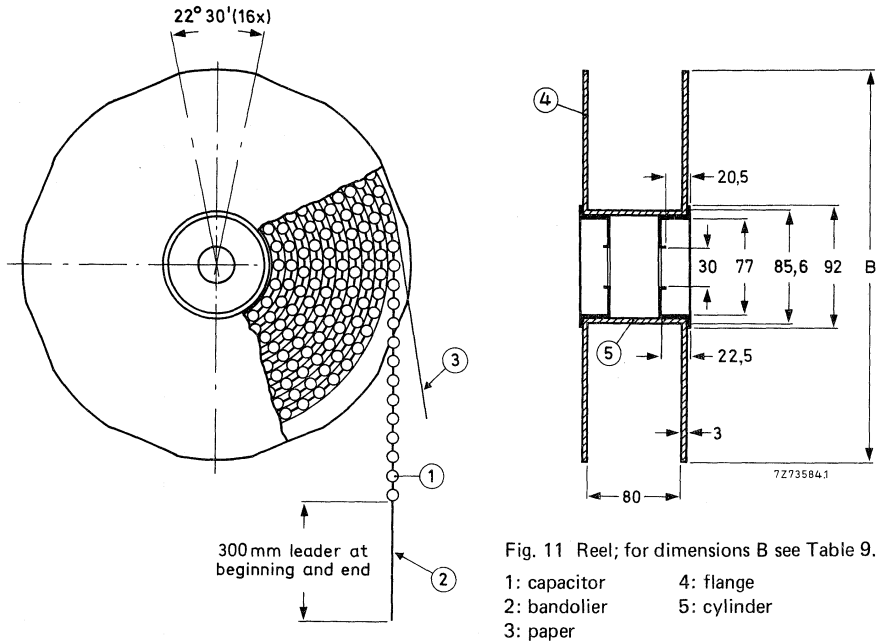

Fig. 11 Reel; for dimensions B see Table 9.

- 1: capacitor
- 2: bandolier
- 3: paper
- 4: flange
- 5: cylinder

Table 9

capacitance values (pF) of				B	number of capacitors on one reel
63 V version	160 V version	250 V version	630 V version		
2 000— 2 400	1 100	560— 680	51— 300	305	3 000
2 700— 5 600	1 200— 2 700	750— 1 500	330— 680	305	2 500
6 200—20 000	3 000—10 000	1 600— 6 200	750—2 700	356	1 500
22 000—39 000	11 000—16 000	6 800—11 000	3 000—5 600	356	1 000

Characteristics concerning taped capacitors:

- Pull-out force of the component ≥ 2 N
- Tearing force of tape ≥ 10 N

Storage conditions:

- Storage temperature range -25 to $+40$ °C
- Relative humidity $\leq 80\%$

POLYSTYRENE FILM/FOIL CAPACITORS

KS radial potted type

- Supplied loose in boxes

QUICK REFERENCE DATA

Rated capacitance range (E96-series)	100 to 34 000 pF
Tolerance on rated capacitance	± 1%
Rated voltage U_R (d.c.)	63 V
Climatic category	
class 1	55/070/56
class 3	55/085/56
Rated temperature	
class 1	70 °C
class 2	85 °C
Related specification	IEC 384-7
Stability class	1 and 3

STYLE



2222 443
 Pitch: 2,54 mm, 5,08 mm, 7,62 mm
 See Table 1

APPLICATION

For use in LC filters, particularly in telephony equipment, where high requirements are imposed on precision, stability, humidity, dissipation factor and reliability. The dimensions are such that, in combination with currently available ferrites, a high package density is possible.

DESCRIPTION

The capacitors consist of a low-inductance wound cell of polystyrene film and metal foil. The cell is potted with epoxy resin in a yellow flame retardent polypropylene case, which can withstand solvents and rinsing liquids.

The low thermal conductivity of the radial leads provides optimum soldering conditions. The capacitors are provided with stand-off ridges to give a clearance between the capacitors and the printed-wiring board.

GENERAL DATA

Dimensions in mm

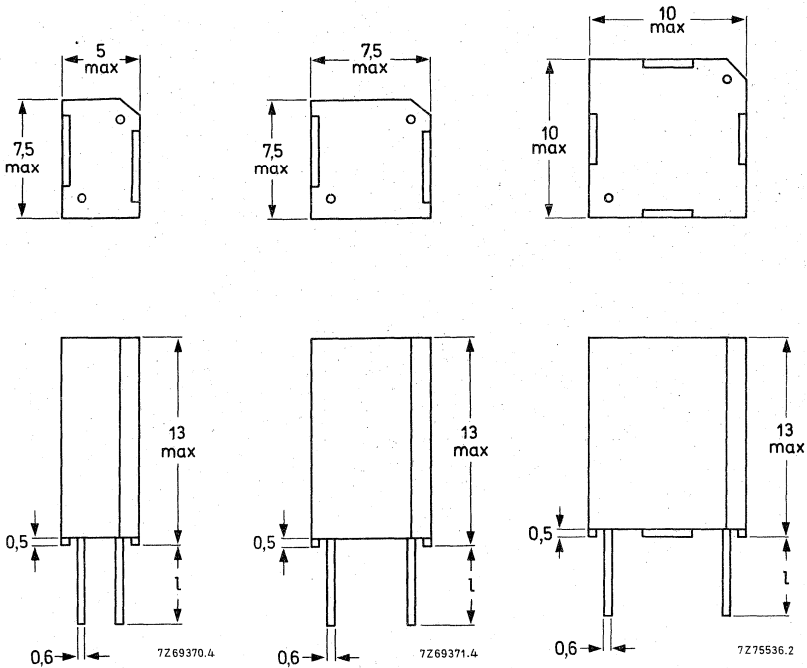

Fig. 1 Capacitors of rated capacitance range 100 to 3920 pF.

Fig. 2 Capacitors of rated capacitance range 100 to 15 000 pF.

Fig. 3 Capacitors of rated capacitance range 15 400 to 34 000 pF.

Table 1 U_R (d.c.) = 63 V; max. a.c. voltage = 25 V

rated capacitance* pF	T_{max} mm	L_{max} mm	catalogue number 2222 443		T_{max} mm	L_{max} mm	catalogue number 2222 443	
			$\ell = 3 + 0,4$ 6	$\ell = 5 - 1$ 4			$\ell = 3 + 0,4$ 7	$\ell = 5 - 1$ 8
100			1001				1001	
102			1021				1021	
105			1051				1051	
107			1071				1071	
110			1101				1101	
113			1131				1131	
115			1151				1151	
118			1181				1181	
121			1211				1211	
124			1241				1241	
127			1271				1271	
130			1301				1301	
133			1331				1331	
137			1371				1371	
140			1401				1401	
143			1431				1431	
147			1471				1471	
150			1501				1501	
154			1541				1541	
158			1581				1581	
162	5	7,5	1621		7,5	7,5	1621	
165			1651				1651	
169			1691				1691	
174			1741				1741	
178			1781				1781	
182			1821				1821	
187			1871				1871	
191			1911				1911	
196			1961				1961	
200			2001				2001	
205			2051				2051	
210			2101				2101	
215			2151				2151	
221			2211				2211	
226			2261				2261	
232			2321				2321	
237			2371				2371	
243			2431				2431	
249			2491				2491	
255			2551				2551	
261			2611				2611	
267			2671				2671	

* Besides the values of the E96 series as quoted, intermediate values of the E192 series (with a tolerance $\pm 1\%$) are available.

Table 1 (continued) U_R (d.c.) = 63 V; max. a.c. voltage = 25 V

rated capacitance*	T_{max}	L_{max}	catalogue number 2222 443		T_{max}	L_{max}	catalogue number 2222 443	
			$\ell = 3 + 0,4$	$\ell = 5 - 1$			$\ell = 3 + 0,4$	$\ell = 5 - 1$
			6	4			7	8
pF	mm	mm			mm	mm		
274				2741				2741
280				2801				2801
287				2871				2871
294				2941				2941
301				3011				3011
309				3091				3091
316				3161				3161
324				3241				3241
332				3321				3321
340				3401				3401
348				3481				3481
357				3571				3571
365				3651				3651
374				3741				3741
383				3831				3831
392				3921				3921
402				4021				4021
412				4121				4121
422				4221				4221
432				4321				4321
442				4421				4421
453	5	7,5		4531	7,5	7,5		4531
464				4641				4641
475				4751				4751
487				4871				4871
499				4991				4991
511				5111				5111
523				5231				5231
536				5361				5361
549				5491				5491
562				5621				5621
576				5761				5761
590				5901				5901
604				6041				6041
619				6191				6191
634				6341				6341
649				6491				6491
665				6651				6651
681				6811				6811
698				6981				6981
715				7151				7151
732				7321				7321

* Besides the values of the E96 series as quoted, intermediate values of the E192 series (with a tolerance $\pm 1\%$) are available.

Table 1 (continued) U_R (d.c.) = 63 V; max. a.c. voltage = 25 V

rated capacitance* pF	T_{max} mm	L_{max} mm	catalogue number 2222 443		T_{max} mm	L_{max} mm	catalogue number 2222 443	
			$\ell = 3 + 0,4$ 6	$\ell = 5 - 1$ 4			$\ell = 3 + 0,4$ 7	$\ell = 5 - 1$ 8
750			7501				7501	
768			7681				7681	
787			7871				7871	
806			8061				8061	
825			8251				8251	
845			8451				8451	
866			8661				8661	
887			8871				8871	
909			9091				9091	
931			9311				9311	
953			9531				9531	
976			9761				9761	
1000			1002				1002	
1020			1022				1022	
1050			1052				1052	
1070			1072				1072	
1100			1102				1102	
1130			1132				1132	
1150			1152				1152	
1180			1182				1182	
1210	5	7,5	1212		7,5	7,5	1212	
1240			1242				1242	
1270			1272				1272	
1300			1302				1302	
1330			1332				1332	
1370			1372				1372	
1400			1402				1402	
1430			1432				1432	
1470			1472				1472	
1500			1502				1502	
1540			1542				1542	
1580			1582				1582	
1620			1622				1622	
1650			1652				1652	
1690			1692				1692	
1740			1742				1742	
1780			1782				1782	
1820			1822				1822	
1870			1872				1872	
1910			1912				1912	
1960			1962				1962	
2000			2002				2002	

* Besides the values of the E96 series as quoted, intermediate values of the E192 series (with a tolerance $\pm 1\%$) are available.

Table 1 (continued) U_R (d.c.) = 63 V; max. a.c. voltage = 25 V

rated capacitance* pF	T_{max} mm	L_{max} mm	catalogue number 2222 443		T_{max} mm	L_{max} mm	catalogue number 2222 443	
			$\ell = 3 + 0,4$ 6	$\ell = 5 - 1$ 4			$\ell = 3 + 0,4$ 7	$\ell = 5 - 1$ 8
2050				2052				2052
2100				2102				2102
2150				2152				2152
2210				2212				2212
2260				2262				2262
2320				2322				2322
2370				2372				2372
2430				2432				2432
2490				2492				2492
2550				2552				2552
2610				2612				2612
2670				2672				2672
2740				2742				2742
2800				2802				2802
2870	5	7,5		2872	7,5	7,5		2872
2940				2942				2942
3010				3012				3012
3090				3092				3092
3160				3162				3162
3240				3242				3242
3320				3322				3322
3400				3402				3402
3480				3482				3482
3570				3572				3572
3650				3652				3652
3740				3742				3742
3830				3832				3832
3920				3922				3922
4120				4122				4122
4220				4222				4222
4320				4322				4322
4420				4422				4422
4530				4532				4532
4640				4642				4642
4750				4752				4752
4870	7,5	7,5		4872				4872
4990				4992				4992
5110				5112				5112
5230				5232				5232
5360				5362				5362
5490				5492				5492
5620				5622				5622

* Besides the values of the E96 series as quoted, intermediate values of the E192 series (with a tolerance $\pm 1\%$) are available.

Table 1 (continued) U_R (d.c.) = 63 V; max. a.c. voltage = 25 V

rated capacitance* pF	T_{max} mm	L_{max} mm	catalogue number 2222 443	
			$\ell = 3 + 0,4$ 6	$\ell = 5 - 1$ 4
5760				5762
5900				5902
6040				6042
6190				6192
6340				6342
6490				6492
6650				6652
6810				6812
6980				6982
7150				7152
7320				7322
7500				7502
7680				7682
7870				7872
8060				8062
8250				8252
8450				8452
8660				8662
8870				8872
9090				9092
9310	7,5	7,5		9312
9530				9532
9760				9762
10000				1003
10200				1023
10500				1053
10700				1073
11000				1103
11300				1133
11500				1153
11800				1183
12100				1213
12400				1243
12700				1273
13000				1303
13300				1333
13700				1373
14000				1403
14300				1433
14700				1473
15000				1503

* Besides the values of the E96 series as quoted, intermediate values of the E192 series (with a tolerance $\pm 1\%$) are available.

Table 1 (continued) U_R (d.c.) = 63 V; max. a.c. voltage = 25 V

rated capacitance*	T_{max}	L_{max}	catalogue number 2222 443	
			$\varrho = 3 + 0,4$ 6	$\varrho = 5 - 1$ 4
pF	mm	mm		
15400				1543
15800				1583
16200				1623
16500				1653
16900				1693
17400				1743
17800				1783
18200				1823
18700				1873
19100				1913
20000				2003
21000				2103
21500				2153
22100				2213
22600				2263
23200	10	10		2323
23700				2373
24300				2433
24900				2493
25500				2553
26100				2613
27400				2743
28000				2803
28700				2873
29400				2943
30100				3013
30900				3093
31600				3163
32400				3243
33200				3323
34000				3403

* Besides the values of the E96 series as quoted, intermediate values of the E192 series (with a tolerance $\pm 1\%$) are available.

Marking

- a. Rated capacitance
- b. Rated voltage
- c. Tolerance on rated capacitance
- d. Category voltage
- e. Year and month of manufacture
- f. Manufacturer's name
- g. Climatic category
- h. Manufacturer's type designation

The capacitors are marked in black ink as follows:

- Capacitors according to Fig. 1 are marked on the top with a, b, c and e:
 - 1st line: rated capacitance in pF;
 - 2nd line: tolerance code ($F = \pm 1\%$) and rated voltage (d.c.);
 - 3rd line: production date code according to IEC 62, clause 5, and code for dielectric (KS).

Note

The earth side is indicated by a vertical line to the left of the 2nd and 3rd lines of marking, and by the bevelled corner.

- Capacitors according to Figs 2 and 3 are marked on the top with a, b, c, e, f and h:
 - 1st line: rated capacitance in pF;
 - 2nd line: tolerance code ($F = \pm 1\%$) and rated voltage (d.c.);
 - 3rd line: 5th, 6th and 7th digits of the catalogue number;
 - 4th line: production date code according to IEC 62, clause 5, and code for dielectric (KS).

The manufacturer's identification symbol is indicated to the left of the 2nd and 3rd lines of marking.

Note

The earth side is indicated by a vertical line to the left of the 2nd, 3rd and 4th lines of marking, and by the bevelled corner.

The package containing the capacitors is marked with a to h.

Mounting

The capacitors are designed for mounting on printed-wiring boards. The required space on the printed-wiring board for a hole diameter of 1 mm is given in Figs 4, 5 and 6.

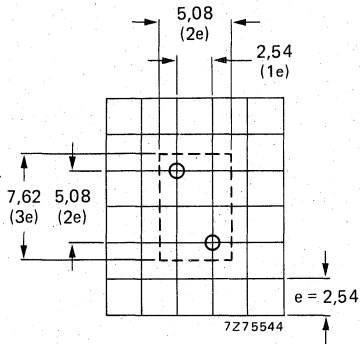

Fig. 4 Required space for capacitors according to Fig. 1.

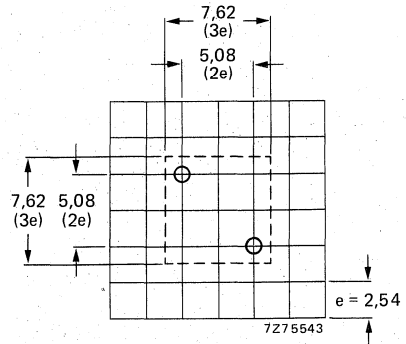

Fig. 5 Required space for capacitors according to Fig. 2.

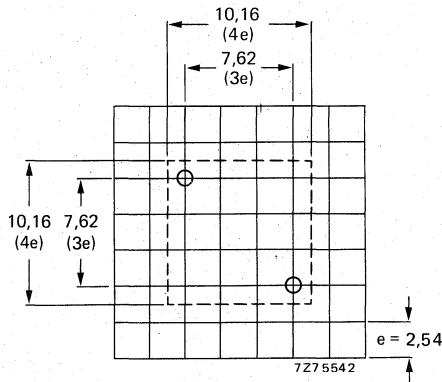

Fig. 6 Required space for capacitors according to Fig. 3.

Ratings and characteristics

Unless otherwise specified all electrical values apply to an ambient free air temperature of $23 \pm 1 \text{ }^\circ\text{C}$, an atmospheric pressure of 86 to 106 kPa and a relative humidity of $50 \pm 2\%$.

Capacitance

Rated capacitance

at 1 kHz, $C_R > 1000 \text{ pF}$ and

at 1 MHz, $C_R \leq 1000 \text{ pF}$

see Table 1

Tolerance on rated capacitance

$\pm 1\%$

Temperature coefficient

$C_R \leq 15000 \text{ pF}$

$-(125 \pm 30) \times 10^{-6}/\text{K}$

$C_R > 15000 \text{ pF}$

$-(160 \pm 40) \times 10^{-6}/\text{K}$

Frequency dependence between 100 Hz and 1 MHz

none

Voltage

Rated voltage U_R (d.c.)

63 V

Category voltage U_C

U_R (d.c.)

Test voltage

between terminations

$2 \times U_R$ (d.c.)

between interconnected terminations and case (foil method)

400 V (d.c.)

Maximum a.c. voltage (r.m.s. value) at 50 to 60 Hz

25 V

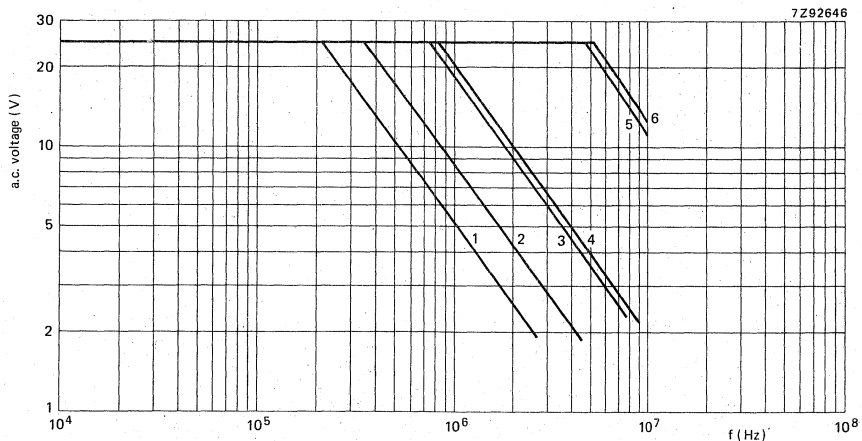

Fig. 7 Maximum a.c. voltage (r.m.s. value) as a function of frequency at $T_{amb} \leq 55 \text{ }^\circ\text{C}$.

Curve 1 = 34000 pF;

curve 2 = 15000 pF;

curve 3 = 3920 pF, according to Fig. 1;

curve 4 = 3920 pF, according to Fig. 2;

curve 5 = 100 pF, according to Fig. 1;

curve 6 = 100 pF, according to Fig. 2.

Notes

- The sum of the d.c. voltage and the peak value of the superimposed a.c. voltage must be $\leq U_R$ (d.c.).
- For waveforms other than sinusoidal the maximum permissible dissipation must not be exceeded.

Temperature

Climatic category

- class 1
- class 3

55/070/56

55/085/56

Rated temperature

- class 1
- class 3

70 °C

85 °C

Storage temperature range

- class 1
- class 3

-55 to + 70 °C

-55 to + 85 °C

Tangent of loss angle

Table 2

capacitance	tangent of loss angle		
	at 1 kHz	at 100 kHz	at 1 MHz
$C_R \leq 500 \text{ pF}$	$\leq 5 \times 10^{-4}$		$\leq 5 \times 10^{-4}$
$500 \text{ pF} < C_R \leq 1\,000 \text{ pF}$	$\leq 5 \times 10^{-4}$		$\leq 10 \times 10^{-4}$
$1\,000 \text{ pF} < C_R \leq 10\,000 \text{ pF}$	$\leq 5 \times 10^{-4}$	$\leq 10 \times 10^{-4}$	
$10\,000 \text{ pF} < C_R \leq 15\,000 \text{ pF}$	$\leq 5 \times 10^{-4}$	$\leq 15 \times 10^{-4}$	
$15\,000 \text{ pF} < C_R \leq 20\,000 \text{ pF}$	$\leq 5 \times 10^{-4}$	$\leq 25 \times 10^{-4}$	
$20\,000 \text{ pF} < C_R \leq 30\,000 \text{ pF}$	$\leq 5 \times 10^{-4}$	$\leq 40 \times 10^{-4}$	
$C_R > 30\,000 \text{ pF}$	$\leq 5 \times 10^{-4}$	$\leq 60 \times 10^{-4}$	

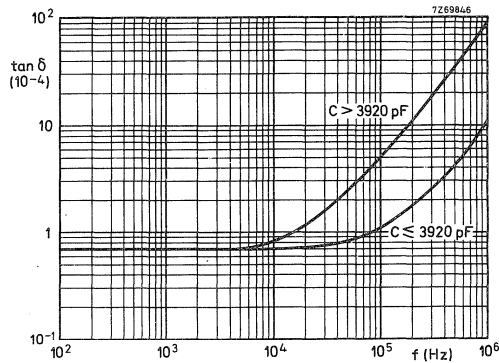

Fig. 8 Tan δ as a function of frequency; typical curve.

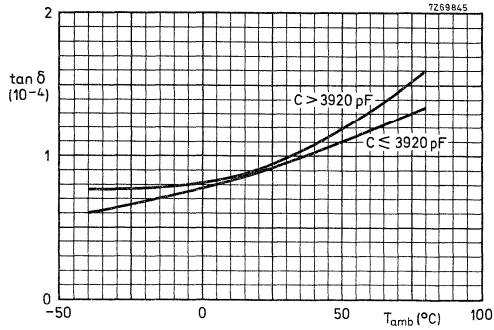

Fig. 9 Tan δ as a function of ambient free air temperature; typical curve.

Insulation resistance

The insulation resistance is measured after a voltage of 10 ± 1 V has been applied for $1 \text{ min} \pm 5 \text{ s}$, at $T_{\text{amb}} = 20 \text{ }^\circ\text{C}$.

- R between terminations > 500 000 M Ω
- R between interconnected terminations and case > 500 000 M Ω

Inductance

≤ 10 nH/cm lead and capacitor length

Maximum dissipation

The maximum a.c. voltage, which has been specified at 50 to 60 Hz must also never be exceeded at other frequencies.* Moreover this voltage may further be limited by the maximum dissipation (P_{max}).

For a capacitor used with a sinusoidal voltage, the power dissipation is expressed by:

$$P = V_{\text{rms}} I_{\text{rms}} \cos \varphi. \tag{1}$$

As $I_{\text{rms}} = \omega C V_{\text{rms}}$, and $\cos \varphi \approx \tan \delta$, equation (1) can be rewritten as:

$$P = V_{\text{rms}}^2 \omega C \tan \delta = V_{\text{rms}}^2 2\pi f C \tan \delta. \tag{2}$$

For capacitors of style 2222 443 $\tan \delta$ is about proportional to the frequency, thus:

$$\tan \delta = \frac{f}{10^5} \tan \delta_{\text{ref}}. \tag{3}$$

$\tan \delta_{\text{ref}}$ is the maximum $\tan \delta$ at 100 kHz value given under Ratings and characteristics.

Substituting equation (3) in equation (2) gives:

$$P = 2\pi \cdot 10^{-5} V_{\text{rms}}^2 f^2 C \tan \delta_{\text{ref}}. \tag{4}$$

The maximum dissipation (P_{max}), which depends on the dimensions of the capacitor and on the ambient free air temperature, can be found from Fig. 9.

* At $T_{\text{amb}} \leq 55 \text{ }^\circ\text{C}$ the maximum permissible sinusoidal voltage can be found in Fig. 7.

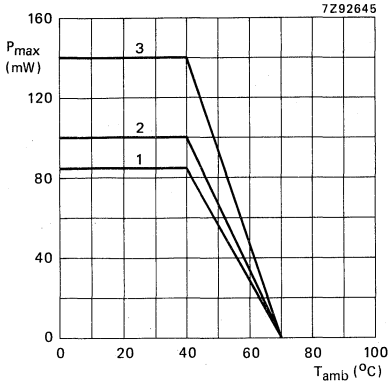

Fig. 10a Maximum dissipation as a function of ambient free air temperature, class 1 capacitors.

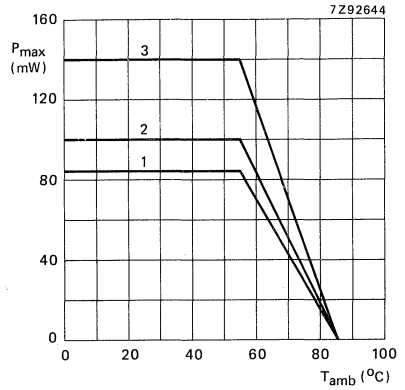

Fig. 10b Maximum dissipation as a function of ambient free air temperature, class 3 capacitors.

Table 3

curve	dimensions (mm)	
	T _{max}	L _{max}
1	5	7,5
2	7,5	7,5
3	10	10

ORDERING INFORMATION

Order the capacitors by quoting the 12-digit catalogue number as given in Table 1.

PACKING

The capacitors are supplied loose in boxes; the number of capacitors per box is shown in Table 4.

Table 4

capacitors according to	number of capacitors per box
Fig. 1 or Fig. 2	200
Fig. 3	100

POLYSTYRENE FILM/FOIL CAPACITORS

KS axial wrapped end-filled

- Supplied loose in boxes

QUICK REFERENCE DATA

Rated capacitance range	6200 to 162 000 pF
Tolerance on rated capacitance	± 5% (E24-series) ± 2% (E24, E48-series) ± 1% (E24, E48, E96-series)
Rated voltage U_R (d.c.)	63 V, 160 V, 250 V, 630 V
Climatic category	
63 V version	40/070/56
160 V, 250 V, 630 V versions	40/085/56
Rated temperature	
63 V version	70 °C
160 V, 250 V, 630 V versions	85 °C
Related specification	IEC 384-7
Stability class	2

SURVEY OF STYLES



Styles 2222 444 to 2222 447
See Tables 1 to 4.

APPLICATION

For use in circuits where close tolerance, reliability and low losses are of prime importance, e.g. tuned circuits, filter networks, timing network, etc.

DESCRIPTION

The capacitors consist of a low-inductance wound cell of metal foil and a polystyrene film. The cell is wrapped in a polyester film, the ends are filled with epoxy resin. The axial leads are of solder-coated wire.

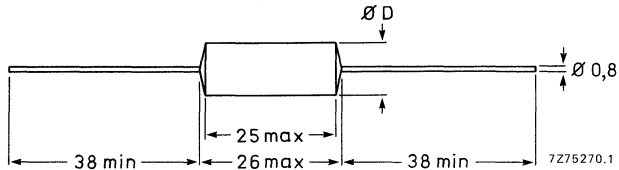

Fig. 1.

Table 1 U_R (d.c.) = 63 V; max. a.c. voltage = 25 V, Fig. 1.

rated capacitance (E24-series, tol. $\pm 5\%$)* pF	D_{max} mm	approx. mass g	catalogue number
43 000	7,0	3,1	2222 444 24303
47 000	7,5	3,2	24703
51 000	7,5	3,4	25103
56 000	8,0	3,7	25603
62 000	8,5	4,0	26203
68 000	8,5	4,4	26803
75 000	9,0	4,7	27503
82 000	9,5	5,1	28203
91 000	9,5	5,5	29103
100 000	10,0	5,9	21004
110 000	10,5	6,4	21104
120 000	11,0	6,9	21204
130 000	11,5	7,5	21304
150 000	12,0	8,2	21504
160 000	12,5	9,0	21604
162 000	12,5	9,1	21624

* The capacitance values quoted are also available with a tolerance $\pm 1\%$ or $\pm 2\%$.

Besides the values of the E24-series as quoted, intermediate values of the E48-series (with a tolerance $\pm 1\%$ or $\pm 2\%$) and of the E96-series (with a tolerance $\pm 1\%$) are available.

Table 2 U_R (d.c.) = 160 V; max. a.c. voltage = 63 V, Fig. 1.

rated capacitance (E24-series, tol. $\pm 5\%$)* pF	D_{\max} mm	approx. mass g	catalogue number
18 000	6,5	2,3	2222 445 21803
20 000	7,0	2,4	22003
22 000	7,0	2,5	22203
24 000	7,5	2,6	22403
27 000	7,5	2,8	22703
30 000	8,0	3,1	23003
33 000	8,5	3,4	23303
36 000	8,5	3,8	23603
39 000	9,0	4,1	23903
43 000	9,5	4,4	24303
47 000	9,5	4,7	24703
51 000	10,0	5,1	25103
56 000	10,5	5,5	25603
62 000	11,0	5,9	26203
68 000	11,5	6,4	26803
75 000	12,0	7,0	27503
82 000	12,5	7,6	28203

Table 3 U_R (d.c.) = 250 V; max. a.c. voltage = 125 V, Fig. 1.

rated capacitance (E24-series, tol. $\pm 5\%$)* pF	D_{\max} mm	approx. mass g	catalogue number
12 000	7,0	2,1	2222 446 21203
13 000	7,0	2,2	21303
15 000	7,5	2,4	21503
16 000	7,5	2,5	21603
18 000	8,0	2,7	21803
20 000	8,0	2,9	22003
22 000	8,5	3,2	22203
24 000	9,0	3,5	22403
27 000	9,5	3,7	22703
30 000	10,0	4,0	23003
33 000	10,5	4,4	23303
36 000	10,5	4,7	23603
39 000	11,0	5,1	23903
43 000	11,5	5,5	24303
47 000	12,0	5,9	24703

* The capacitance values quoted are also available with a tolerance $\pm 1\%$ or $\pm 2\%$.

Besides the values of the E24-series as quoted, intermediate values of the E48-series (with a tolerance $\pm 1\%$ or $\pm 2\%$) and of the E96-series (with a tolerance $\pm 1\%$) are available.

Table 4 U_R (d.c.) = 630 V; max. a.c voltage = 250 V, Fig. 1.

rated capacitance (E24-series, tol. $\pm 5\%$)* pF	D_{\max} mm	approx. mass g	catalogue number
6 200	7,5	2,1	2222 447 26202
6 800	7,5	2,2	26802
7 500	8,0	2,4	27502
8 200	8,0	2,6	28202
9 100	8,5	2,8	29102
10 000	9,0	3,0	21003
11 000	9,0	3,3	21103
12 000	9,5	3,6	21203
13 000	10,0	3,9	21303
15 000	10,5	4,2	21503
16 000	11,0	4,6	21603
18 000	11,5	4,9	21803
20 000	12,0	5,3	22003
22 000	12,5	5,8	22203
24 000	12,5	6,2	22403

Marking

The capacitors are marked in ink as follows:

1st line : rated capacitance in pF or nF, and tolerance;

2nd line : rated voltage (d.c.), and code for dielectric material (KS);

3rd line : 5th, 6th and 7th digits of catalogue number, and production date code (according to IEC 62, clause 5).

The outer film connection is identified with a stroke.

Mounting

The capacitors are suited for horizontal or vertical mounting on printed-wiring boards and for point-to-point wiring.

* The capacitance values quoted are also available with a tolerance $\pm 1\%$ or $\pm 2\%$.

Besides the values of the E24-series as quoted, intermediate values of the E48-series (with a tolerance $\pm 1\%$ or $\pm 2\%$) and of the E96-series (with a tolerance $\pm 1\%$) are available.

Ratings and characteristics

Unless otherwise specified all electrical values apply to an ambient free air temperature of $23 \pm 1 \text{ }^\circ\text{C}$, an atmospheric pressure of 86 to 106 kPa and a relative humidity of $50 \pm 2\%$.

Capacitance

Rated capacitance range at 1 kHz	see Tables 1 to 4
Tolerance on rated capacitance	$\pm 5\%$, $\pm 2\%$ and $\pm 1\%$
Temperature coefficient	$-(125 \pm 60) 10^{-6}/\text{K}$
Frequency dependence between 100 Hz and 1 MHz	none

Voltage

Rated voltage U_R (d.c.)	see Tables 1 to 4
Category voltage U_C	U_R (d.c.)
Test voltage	
between terminations	$2 \times U_R$ (d.c.)
between interconnected terminations and case	$2 \times U_R$ (d.c.); min. 400 V
Maximum a.c. voltage (r.m.s. value) at 50 to 60 Hz	see Tables 1 to 4

Notes

- The sum of the d.c. voltage and the peak value of the superimposed a.c. voltage must be $\leq U_R$ (d.c.)
- For other than sinusoidal waveforms, the maximum permissible dissipation must not exceeded.

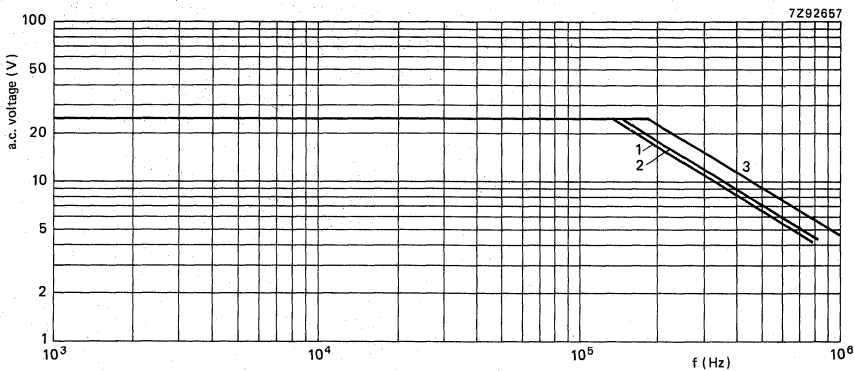

Fig. 2 Maximum a.c. voltage (r.m.s. value) as a function of frequency at $T_{amb} \leq 55 \text{ }^\circ\text{C}$, for $U_R = 63 \text{ V}$.

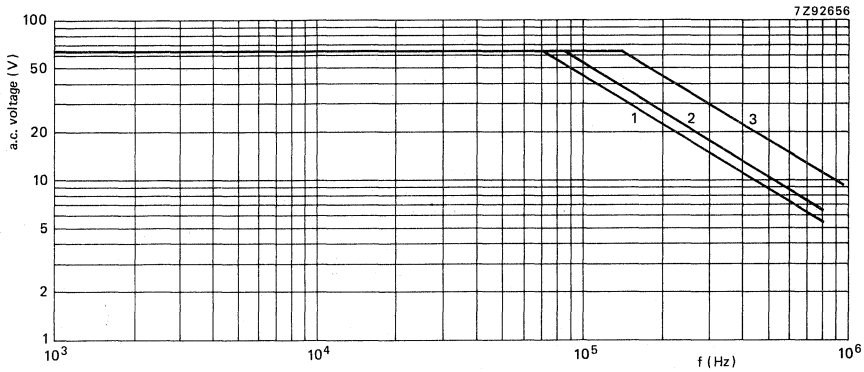

Fig. 3 Maximum a.c. voltage (r.m.s. value) as a function of frequency at $T_{amb} \leq 70^\circ\text{C}$, for $U_R = 160$ V.

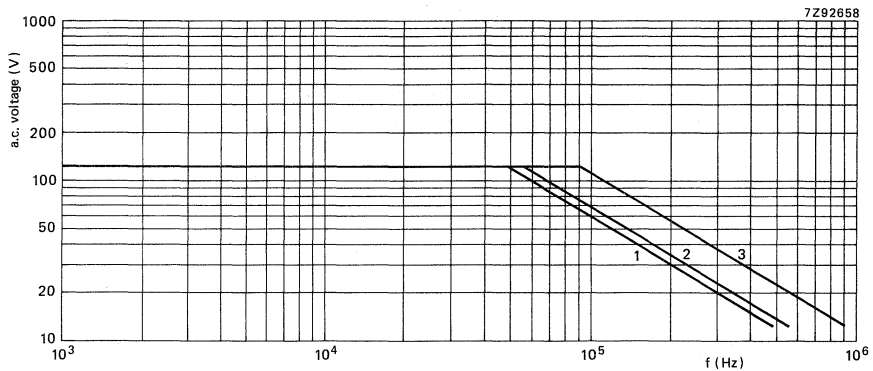

Fig. 4 Maximum a.c. voltage (r.m.s. value) as a function of frequency at $T_{amb} \leq 70^\circ\text{C}$, for $U_R = 250$ V.

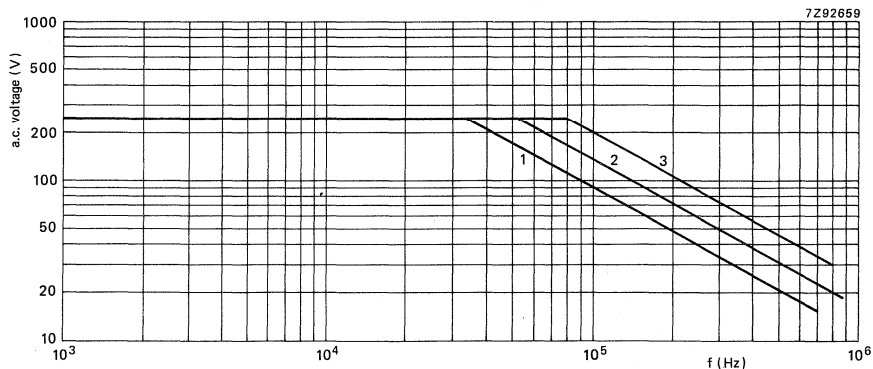

Fig. 5 Maximum a.c. voltage (r.m.s. value) as a function of frequency at $T_{amb} \leq 70^\circ\text{C}$, for $U_R = 630$ V.

Temperature

Climatic category

63 V version 40/070/56

160 V, 250 V, 630 V versions 40/085/56

Rated temperature

63 V version 70 °C

160 V, 250 V, 630 V versions 85 °C

Storage temperature range

63 V version -40 to + 70 °C

160 V, 250 V, 630 V versions -40 to + 85 °C

Tangent of loss angle

Table 5

capacitance	tangent of loss angle	
	at 1 kHz	at 100 kHz
$6\,200\text{ pF} < C_R \leq 10\,000\text{ pF}$	$\leq 5 \times 10^{-4}$	$\leq 10 \times 10^{-4}$
$10\,000\text{ pF} < C_R \leq 20\,000\text{ pF}$	$\leq 5 \times 10^{-4}$	$\leq 15 \times 10^{-4}$
$C_R > 20\,000\text{ pF}$	$\leq 5 \times 10^{-4}$	$\leq 25 \times 10^{-4}$

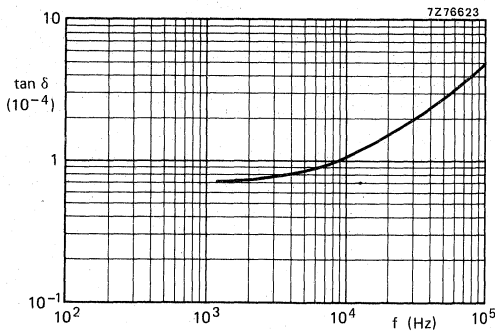

Fig. 6 $\tan \delta$ as a function of frequency; typical curve.

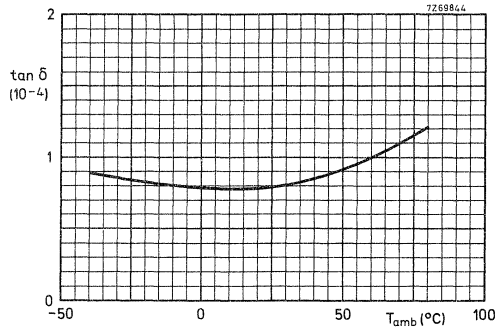

Fig. 7 Tan δ as a function of ambient free air temperature; typical curve.

Insulation resistance at $T_{amb} = 20\text{ }^{\circ}\text{C}$

The insulation resistance is measured after a voltage has been applied for $1\text{ min} \pm 5\text{ s}$, the voltage being $10 \pm 1\text{ V}$ for the 63 V version, $100 \pm 15\text{ V}$ for the 160 V and 250 V versions, and $500 \pm 50\text{ V}$ for the 630 V version.

- R between terminations > 500 000 M Ω
- R between interconnected terminations and case > 500 000 M Ω

Inductance $\leq 10\text{ nH/cm}$ lead and capacitor length

Maximum dissipation

The maximum a.c. voltage, which has been specified at 50 to 60 Hz must also never be exceeded at other frequencies.* Moreover this voltage may further be limited by the maximum dissipation (P_{max}).

For a capacitor used with a sinusoidal voltage, the power dissipation is expressed by:

$$P = V_{rms} I_{rms} \cos \varphi. \tag{1}$$

As $I_{rms} = \omega C V_{rms}$, and $\cos \varphi \approx \tan \delta$, equation (1) can be rewritten as:

$$P = V_{rms}^2 \omega C \tan \delta = V_{rms}^2 2\pi f C \tan \delta. \tag{2}$$

For capacitors of styles 2222 444 to 2222 447 tan δ is about proportional to the frequency, thus:

$$\tan \delta = \frac{f}{10^5} \tan \delta_{ref}. \tag{3}$$

Tan δ_{ref} is the maximum tan δ at 100 kHz value given under Ratings and characteristics.

Substituting equation (3) in equation (2) gives:

$$P = 2\pi \cdot 10^{-5} V_{rms}^2 f^2 C \tan \delta_{ref}. \tag{4}$$

The maximum dissipation (P_{max}), which depends on the dimensions of the capacitor and on the ambient free air temperature, can be found from Fig. 8.

* At $T_{amb} \leq 70\text{ }^{\circ}\text{C}$ ($\leq 55\text{ }^{\circ}\text{C}$ for 63 V version) the maximum permissible sinusoidal voltage can be found in Figs 2 to 5.

Table 6

curve	dimensions (mm)	
	D _{max}	L _{max}
1	6,5	25
2	7,0	
3	7,5	
4	8,0	
5	8,5	
6	9,0	
7	9,5	
8	10,0	
9	10,5	
10	11,0	
11	11,5	
12	12,0	
13	12,5	

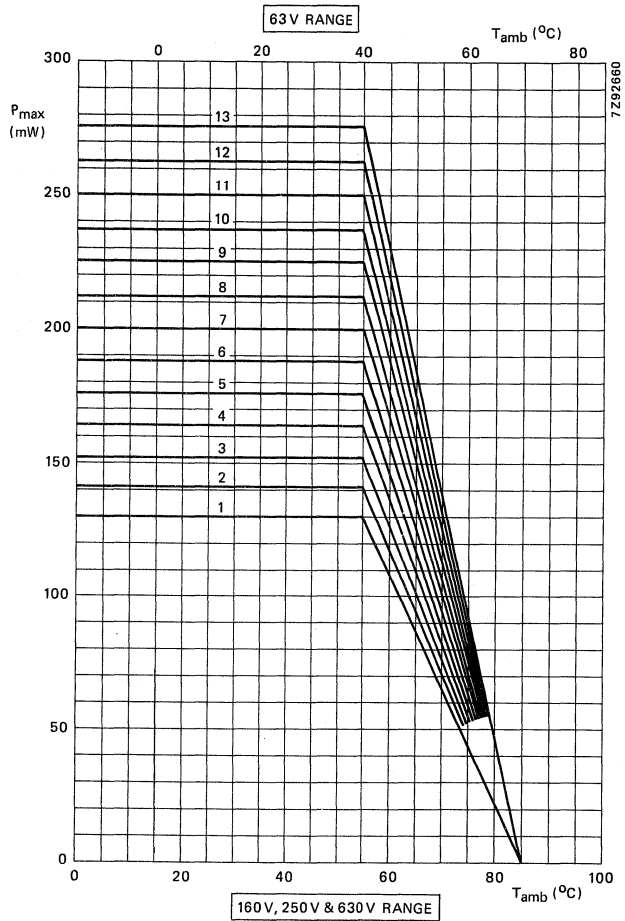
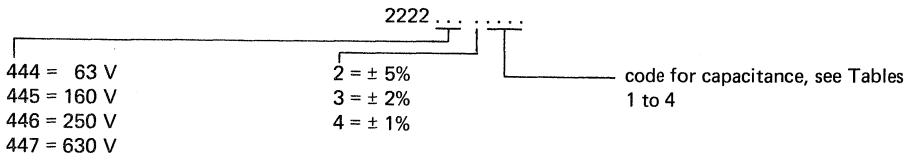

Fig. 8 Maximum dissipation as a function of ambient free air temperature.

ORDERING INFORMATION

Order the capacitors by quoting the 12-digit catalogue number.

Composition of the catalogue number (see Tables 1 to 4).



2222 444 —
2222 447

PACKING

The capacitors are supplied loose in cardboard boxes; the number of capacitors per box is given in Table 7.

Table 7

capacitance values (pF) of				number of capacitors per box
63 V version	160 V version	250 V version	630 V version	
43 000- 56 000	18 000-30 000	12 000-18 000	6 200- 8 200	600
62 000- 91 000	33 000-47 000	20 000-27 000	9 100-12 000	500
100 000-130 000	51 000-68 000	30 000-43 000	13 000-18 000	400
150 000-162 000	75 000-82 000	47 000	20 000-24 000	300

INSPECTION REQUIREMENTS

polystyrene film/foil capacitors (KS)

Note 1

Sub-clause numbers of tests and performance requirements refer to the Sectional Specification, IEC-publication 384-7 and GENERAL DATA of the specifications.

Note 2

In this table: D = destructive, ND = non-destructive.

clause number and test (see Note 1)	D or ND	conditions of test (see Note 1)	performance requirements 2222 424 to 431
Group A Inspection (lot-by-lot)			
Sub-group A1	ND		
4.1 Visual examination			No mechanical failures. Legible marking and as specified in GENERAL DATA of the specification.
4.2 Dimensions		Gauging	As specified in the Tables of the specification.
Sub-group A2	ND		
4.2.1 Voltage proof (Test A)		at $2 \times U_R$ (d.c.) for 1 s	No breakdown or flashover.
4.2.2 Capacitance		at 1 kHz	Within specified tolerance.
4.2.3 Tangent of loss angle		for $C_R \leq 1000$ pF at 1 MHz, for $C_R > 1000$ pF at 100 kHz.	As in GENERAL DATA of the specification.

performance requirements
2222 443

performance requirements
2222 444 to 447

No mechanical failures.
Legible marking and as
specified in GENERAL
DATA of the specification.
As specified in the Table
of the specification.

No mechanical failures.
Legible marking and as
specified in GENERAL
DATA of the specification.
As specified in the Tables
of the specification.

No breakdown or flashover.
Within specified tolerance.
As in GENERAL DATA
of the specification.

No breakdown or flashover.
Within specified tolerance.
As in GENERAL DATA
of the specification.

sub-clause number and test (see Note 1)	D or ND	conditions of test (see Note 1)	performance requirements 2222 424 to 431
Group B Inspection (periodic) 4.5 Solderability	D	Without ageing Method: 1 Solder bath: 235 °C Dwell time: 2 s Non-activated colophony flux	Good tinning as evidenced by free flowing of the solder with wetting of the terminations.
Group C Inspection (periodic) Sub-group C1A Part of sample of sub-group C1 4.1 Dimensions (detail) 4.3.1 Initial measurements 4.3 Robustness of terminations 4.4 Resistance to soldering heat 4.4.2 Final measurements	D	Capacitance for $C_R \leq 1000 \text{ pF}$ at 100 kHz, $C_R > 1000 \text{ pF}$ at 1 kHz Tangent of loss angle for $C_R \leq 1000 \text{ pF}$ at 1 MHz, $C_R > 1000 \text{ pF}$ at 100 kHz Tensile, bending and torsion No pre-drying Method: 1A Solder bath: 260 °C Duration: 5 s Visual examination Capacitance Tangent of loss angle	As specified in the Tables of the specification. No visible damage. No visible damage. Legible marking. $\Delta C/C \leq 1\% + 1 \text{ pF}$ for $C_R \leq 1000 \text{ pF}$, $\leq 1\%$ for $C_R > 1000 \text{ pF}$ of the value measured in 4.3.1. As in GENERAL DATA of the specification.

performance requirements 2222 443	performance requirements 2222 444 to 447
<p>Good tinning as evidenced by free flowing of the solder with wetting of the terminations.</p>	<p>Good tinning as evidenced by free flowing of the solder with wetting of the terminations.</p>
<p>As specified in the Table of the specification.</p>	<p>As specified in the Tables of the specification.</p>
<p>No visible damage.</p>	<p>No visible damage.</p>
<p>No visible damage. Legible marking. $\Delta C/C \leq 0,5\% + 0,5 \text{ pF}$ for $C_R \leq 1000 \text{ pF}$, $\leq 0,5\%$ for $C_R > 1000 \text{ pF}$ of the value measured in 4.3.1. As in GENERAL DATA of the specification.</p>	<p>No visible damage. Legible marking $\Delta C/C \leq 0,5\%$ of the value measured in 4.3.1. As in GENERAL DATA of the specification.</p>

sub-clause number and test (see Note 1)	D or ND	conditions of test (see Note 1)	performance requirements 2222 424 to 431
Sub-group C1B Other part of sample of sub-group C1	D		
4.6.1 Initial measurements		Capacitance for $C_R \leq 1000 \text{ pF}$ at 100 kHz, $C_R > 1000 \text{ pF}$ at 1 kHz Tangent of loss angle for $C_R \leq 1000 \text{ pF}$ at 1 MHz, $C_R > 1000 \text{ pF}$ at 100 kHz	
4.6 Rapid change of temperature		θ A = lower cat. temp. θ B = upper cat. temp. 5 cycles, duration $t = 30 \text{ min.}$ Recovery 1 to 2 h	
4.6.2 Intermediate measurements		Visual examination Capacitance	No visible damage. $\Delta C/C \leq 0,5\% + 0,5 \text{ pF}$ for $C_R \leq 1000 \text{ pF}$, $\leq 0,5\%$ for $C_R > 1000 \text{ pF}$ of the value measured in 4.6.1.
4.7 Vibration		Tangent of loss angle Method of mounting see Note below. Procedure B4. Frequency range: 10 to 55 Hz Pulse shape: half sine Amplitude: 0,75 mm or acceleration: 98 m/s^2 (whichever is the less severe). Total duration: 6 h	As in GENERAL DATA of the specification.
4.7.2 Final inspection Intermediate measurements		Visual examination Capacitance	No visible damage. $\Delta C/C \leq 0,5\% + 0,5 \text{ pF}$ for $C_R \leq 1000 \text{ pF}$, $\leq 0,5\%$ for $C_R > 1000 \text{ pF}$ of the value measured in 4.6.2.

Note

The capacitors shall be mechanically fixed by the leads, also the body of capacitors with a mass $> 2 \text{ g}$ shall be clamped to the printed-wiring board.

performance requirements
2222 443

performance requirements
2222 444 to 447

No visible damage.

Class 1:

$\Delta C/C \leq 0,3\% + 0,3 \text{ pF}$

for $C_R \leq 1000 \text{ pF}$,

$\leq 0,3\%$ for $C_R > 1000 \text{ pF}$ of
value measured in 4.6.1.

Class 3:

$\Delta C/C \leq 0,75\% + 0,75 \text{ pF}$

for $C_R \leq 1000 \text{ pF}$,

$\leq 0,75\%$ for $C_R > 1000 \text{ pF}$ of
the value measured in 4.6.1.

As in GENERAL DATA
of the specification.

No visible damage.

$\Delta C/C \leq 0,5\%$ of the value
measured in 4.6.1.

As in GENERAL DATA
of the specification.

No visible damage.

$\Delta C/C \leq 0,1\%$ of the value
measured in 4.6.2.

No visible damage.

$\Delta C/C \leq 0,5\%$ of the value
measured in 4.6.2.

sub-clause number and test (see Note 1)	D or ND	conditions of test (see Note 1)	performance requirements 2222 424 to 431
4.9 Shock 4.9.3 Final measurements		Method of mounting see Note below. Pulse shape: half sine Acceleration: 490 m/s ² Duration of pulse: 11 ms Visual examination Capacitance	No visible damage. $\Delta C/C \leq 0,5\% + 0,5 \text{ pF}$ for $C_R \leq 1000 \text{ pF}$, $\leq 0,5\%$ for $C_R > 1000 \text{ pF}$ of the value measured in 4.7.2.

Note

The capacitors shall be mechanically fixed by the leads, also the body of capacitors with a mass $> 2 \text{ g}$ shall be clamped to the printed-wiring board.

performance requirements
2222 443

performance requirements
2222 444 to 447

No visible damage.
Class 1:
 $\Delta C/C \leq 0,5\%$,
Class 3:
 $\Delta C/C \leq 1\%$ of the value
measured in 4.7.2.

No visible damage.
 $\Delta C/C \leq 0,5\%$ of the value
measured in 4.7.2.

sub-clause number and test (see Note 1)	D or ND	conditions of test (see Note 1)	performance requirements 2222 424 to 431
<p>Sub-group C1</p> <p>Combined sample of specimens of Sub-groups C1A and C1B</p> <p>4.10 Climatic sequence</p> <p>4.10.2 Initial measurements</p> <p>4.10.3 Dry heat</p> <p>4.10.4 Damp heat cyclic, Test Db, first cycle</p> <p>4.10.5 Cold</p> <p>4.10.7 Damp heat cyclic, Test Db remaining cycles</p> <p>4.10.7 Final measurements</p>	D	<p>Capacitance for $C_R \leq 1000 \text{ pF}$ at 100 kHz, $C_R > 1000 \text{ pF}$ at 1 kHz Tangent of loss angle for $C_R \leq 1000 \text{ pF}$ at 1 MHz, $C_R > 1000 \text{ pF}$ at 100 kHz Insulation resistance</p> <p>Temperature: upper category temperature Duration: 16 h</p> <p>Temperature: lower category temperature Duration: 2 h</p> <p>Recovery: 1 to 2 h</p> <p>Visual examination</p> <p>Capacitance</p> <p>Tangent of loss angle</p> <p>Insulation resistance</p>	<p>No visible damage. Legible marking. $\Delta C/C \leq 1\% + 1 \text{ pF}$ for $C_R \leq 1000 \text{ pF}$, $\leq 1\%$ for $C_R > 1000 \text{ pF}$ of the value measured in 4.10.2.</p> <p>$\leq 2 \times$ values specified in GENERAL DATA of the specification. $\geq 50\%$ of values in GENERAL DATA of the specification.</p>

performance requirements
2222 443

performance requirements
2222 444 to 447

No visible damage.
Legible marking.
Class 1:
 $\Delta C/C \leq 0,5\% + 1 \text{ pF}$ for
 $C_R \leq 1000 \text{ pF}$,
 $\leq 0,5\%$ for $C_R > 1000 \text{ pF}$
of the value measured in 4.10.2.
Class 3:
 $\Delta C/C \leq 1\% + 1 \text{ pF}$
for $C_R \leq 1000 \text{ pF}$,
 $\leq 1\%$ for $C_R > 1000 \text{ pF}$
of the value measured in 4.10.2.
 $\leq 2 \times$ values specified in
GENERAL DATA of the
specification.
 $\geq 20\%$ of values in GENERAL
DATA of the specification.

No visible damage.
Legible marking.
 $\Delta C/C \leq 0,5\%$ of the value
measured in 4.10.2.

$\leq 2 \times$ values specified in
GENERAL DATA of the
specification.
 $\geq 20\%$ of values in GENERAL
DATA of the specification.

sub-clause number and test (see Note 1)	D or ND	conditions of test (see Note 1)	performance requirements 2222 424 to 431
Sub-group C2 4.11 Damp heat steady state 4.11.1 Initial measurements 4.11.3 Final measurements	D	Capacitance for $C_R \leq 1000 \text{ pF}$ at 100 kHz, $C_R > 1000 \text{ pF}$ at 1 kHz Tangent of loss angle for $C_R \leq 1000 \text{ pF}$ at 1 MHz, $C_R > 1000 \text{ pF}$ at 100 kHz Recovery: 1 to 2 h Visual examination	
		Capacitance Tangent of loss angle Insulation resistance	No visible damage. Legible marking. $\Delta C/C \leq 1\% + 1 \text{ pF}$ for $C_R \leq 1000 \text{ pF}$, $\leq 1\%$ for $C_R > 1000 \text{ pF}$ of the value measured in 4.11.1. $\leq 2 \times$ values specified in GENERAL DATA of the specification. $\geq 50\%$ of values in GENERAL DATA of the specification.

performance requirements
2222 443

performance requirements
2222 444 to 447

No visible damage.
Legible marking
 $\Delta C/C \leq 0,5\% + 1 \text{ pF}$
for $C_R \leq 1000 \text{ pF}$
 $\leq 0,5\%$ for $C_R > 1000 \text{ pF}$ of
the value measured in 4.11.1.
 $\leq 2 \times$ values specified in
GENERAL DATA of
the specification.
 $\geq 20\%$ of values in GENERAL
DATA of the specification.

No visible damage.
Legible marking.
 $\Delta C/C \leq 0,5\%$ of the value
measured in 4.11.1.
 $\leq 2 \times$ values specified in
GENERAL DATA of
the specification.
 $\geq 20\%$ of values in GENERAL
DATA of the specification.

sub-clause number and test (see Note 1)	D or ND	conditions of test (see Note 1)	performance requirements 2222 424 to 431
Sub-group C3 4.12 Endurance	D	Styles 2222 424 to 431 and 2222 444 to 447:	
		Duration: 1000 h; 1,5 U _R (d.c.) at 70 °C for 63 V version, at 85 °C for 160 V, 250 V, 630 V versions	
4.12.1 Initial measurements		Style 2222 443: Duration: 1000 h; 1,5 U _R (d.c.) at 70 °C for class 1, at 85 °C for class 3 Capacitance for C _R ≤ 1000 pF at 100 kHz, C _R > 1000 pF at 1 kHz Tangent of loss angle for C _R ≤ 1000 pF at 1 MHz, C _R > 1000 pF at 100 kHz	
4.12.5 Final measurements		Visual examination Capacitance Tangent of loss angle Insulation resistance	No visible damage. Legible marking ΔC/C ≤ 0,3% (63 V version), ≤ 0,5% + 0,5 pF (160 V, 250 V, 630 V versions) for C _R ≤ 1000 pF, ≤ 0,5% for C _R > 1000 pF of the value measured in 4.12.1. As in GENERAL DATA of the specification or ≤ 1,4 x value measured in 4.12.1, whichever is greater. As in GENERAL DATA of the specification.

performance requirements
2222 443

performance requirements
2222 444 to 447

No visible damage.
Legible marking.
Class 1:
 $\Delta C/C \leq 0,3\% + 0,3 \text{ pF}$ for
 $C_R \leq 1000 \text{ pF}$,
 $\leq 0,3\%$ for $C_R > 1000 \text{ pF}$;
Class 3:
 $\Delta C/C \leq 0,75\% + 0,75 \text{ pF}$ for
 $C_R \leq 1000 \text{ pF}$,
 $\leq 0,75\%$ for $C_R > 1000 \text{ pF}$ of
the value measured in 4.12.1.
As in GENERAL DATA of
the specification or $\leq 1,4 \times$
value measured in 4.12.1,
whichever is greater.
As in GENERAL DATA
of the specification.

No visible damage
Legible marking.
 $\Delta C/C \leq 0,3\%$ (63 V version),
 $\leq 0,5\%$ (160 V, 250 V, 630 V
versions) of the value measured
in 4.12.1.

As in GENERAL DATA of
the specification or $\leq 1,4 \times$
value measured in 4.12.1,
whichever is greater.
As in GENERAL DATA
of the specification.

sub-clause number and test (see Note 1)	D or ND	conditions of test (see Note 1)	performance requirements 2222 424 to 431
Sub-group C4 4.2.5 Variation of capacitance with temperature	D	Static method; capacitors shall be dried. Number of cycles: 1 Capacitance measurements for $C_R \leq 1000 \text{ pF}$ at 100 kHz, $C_R > 1000 \text{ pF}$ at 1 kHz	Temperature coefficient as in GENERAL DATA of the specification. Temperature cyclic drift of capacitance $\Delta C/C \leq 0,5\% + 0,5 \text{ pF}$ for $C_R \leq 1000 \text{ pF}$ $\leq 0,5\%$ for $C_R > 1000 \text{ pF}$
4.2.6 Inductance		Insulation resistance	$\geq 10\,000 \text{ M}\Omega$. As in GENERAL DATA of the specification.

performance requirements 2222 443	performance requirements 2222 444 to 447
<p>Temperature coefficient as in GENERAL DATA of the specification.</p> <p>Temperature cyclic drift of capacitance Class 1: $\Delta C/C \leq 0,3\% + 0,3 \text{ pF}$ for $C_R \leq 1000 \text{ pF}$, $\leq 0,3\%$ for $C_R > 1000 \text{ pF}$; Class 3: $\Delta C/C \leq 0,75\% + 0,75 \text{ pF}$ for $C_R \leq 1000 \text{ pF}$, $\leq 0,75\%$ for $C_R > 1000 \text{ pF}$ $\geq 10\ 000 \text{ M}\Omega$.</p> <p>As in GENERAL DATA of the specification.</p>	<p>Temperature coefficient as in GENERAL DATA of the specification.</p> <p>Temperature cyclic drift of capacitance $\Delta C/C \leq 0,5\%$</p> <p>$\geq 10\ 000 \text{ M}\Omega$.</p> <p>As in GENERAL DATA of the specification.</p>

additional test	D or ND	conditions of test (see Note 1)	performance requirements 2222 424 to 431
Sub-group ADD1 A.1 Heat storage A.1.1 Initial measurements A.1.2 Final measurements	D	Duration: 1000 h Temperature: upper category temperature Capacitance for $C_R \leq 1000 \text{ pF}$ at 100 kHz, $C_R > 1000 \text{ pF}$ at 1 kHz Tangent of loss angle for $C_R \leq 1000 \text{ pF}$ at 1 MHz, $C_R > 1000 \text{ pF}$ at 100 kHz Capacitance Tangent of loss angle Insulation resistance	$\Delta C/C \leq 0,3\%$ (63 V version), $\leq 0,5\% + 0,5 \text{ pF}$ (160 V, 250 V, 630 V versions) for $C_R \leq 1000 \text{ pF}$, $\leq 0,5\%$ for $C_R > 1000 \text{ pF}$ of the value measured in A.1.1. As in GENERAL DATA of the specification or $\leq 1,4 \times$ value measured in A.1.1, whichever is greater. As in GENERAL DATA of the specification.

performance requirements
2222 443

performance requirements
2222 444 to 447

Class 1:
 $\Delta C/C \leq 0,3\% + 0,3 \text{ pF}$ for
 $C_R \leq 1000 \text{ pF}$,
 $\leq 0,3\%$ for $C_R > 1000 \text{ pF}$;
 Class 3:
 $\Delta C/C \leq 0,75\% + 0,75 \text{ pF}$ for
 $C_R \leq 1000 \text{ pF}$,
 $\leq 0,75\%$ for $C_R > 1000 \text{ pF}$
 of the value measured in A.1.1.
 As in GENERAL DATA of
 the specification or $\leq 1,4 \times$
 value measured in A.1.1,
 whichever is greater.
 As in GENERAL DATA of
 the specification.

$\Delta C/C \leq 0,3\%$ (63 V version),
 $\leq 0,5\%$ (160 V, 250 V, 630 V
 versions) of the value measured
 in A.1.1.

As in GENERAL DATA of
 the specification or $\leq 1,4 \times$
 value measured in A.1.1,
 whichever is greater.
 As in GENERAL DATA of
 the specification.

additional test	D or ND	conditions of test (see Note 1)	performance requirements 2222 424 to 431
Sub-group ADD2 A.2 Endurance for capacitors with max. a.c. voltage ≥ 200 V (r.m.s.) A.2.1 Initial measurements A.2.2 Final measurements		Duration: 1000 h Temperature: 70 °C for 63 V version, 85 °C for 160 V, 250 V, 630 V versions Voltage: 1,25 x max. a.c. voltage (r.m.s. value), 50 Hz Capacitance for $C_R \leq 1000$ pF at 100 kHz, $C_R > 1000$ pF at 1 kHz Tangent of loss angle for $C_R \leq 1000$ pF at 1 MHz, $C_R > 1000$ pF at 100 kHz Capacitance	
		Tangent of loss angle Insulation resistance	For $C_R \leq 1000$ pF: $\Delta C/C \leq 0,3\%$ (63 V version), $\leq 0,5\% + 0,5$ pF (160 V, 250 V, 630 V versions), for $C_R > 1000$ pF: $\Delta C/C \leq 0,5\%$ of the value measured in A.2.1. As in GENERAL DATA of the specification or $\leq 1,4$ x value measured in A.2.1, whichever is greater. As in GENERAL DATA of the specification.

performance requirements
2222 443

performance requirements
2222 444 to 447

Not applicable.

$\Delta C/C \leq 0,5\%$ of the value
measured in A.2.1.

As in GENERAL DATA of
the specification or $\leq 1,4 \times$
value measured in A.2.1,
whichever is greater.
As in GENERAL DATA of
the specification.

additional test	D or ND	conditions of test (see Note 1)	performance requirements 2222 424 to 431
<p>Sub-group ADD3</p> <p>A.3 Resistance to soldering heat with pre-heating</p> <p>A.3.1 Initial measurements</p> <p>A.3.2 Final measurements</p>	D	<p>Capacitors mounted on a 1,6 mm board with non-plated holes</p> <p>Body temp.: 80 °C</p> <p>Bath temp.: 260 °C</p> <p>Dwell time: 5 s</p> <p>Capacitance for $C_R \leq 1000 \text{ pF}$ at 100 kHz, $C_R > 1000 \text{ pF}$ at 1 kHz</p> <p>Capacitance</p>	Not applicable.
<p>Sub-group ADD4</p> <p>A.4 Solvent resistance, Mil STD-202F, method 215 B</p> <p>A.4.1 Initial measurements</p> <p>A.4.2 Final measurements</p>		<p>GROUP 1: De-ionized water, followed by mixture of isopropyl alcohol and mineral spirits</p> <p>GROUP 2: 1-1-1-Trichloroethane</p> <p>GROUP 3: Azeotropic mixture of trichlorotrifluoroethane and methylene chloride Temperature: 25 °C</p> <p>Capacitance for $C_R \leq 1000 \text{ pF}$ at 100 kHz, $C_R > 1000 \text{ pF}$ at 1 kHz</p> <p>Tangent of loss angle for $C_R \leq 1000 \text{ pF}$ at 1 MHz, $1000 \text{ pF} < C_R \leq 15\,000 \text{ pF}$ at 100 kHz, $C_R > 15\,000 \text{ pF}$ at 10 kHz</p> <p>Capacitance</p> <p>Tangent of loss angle</p> <p>Insulation resistance</p>	Not applicable.

performance requirements 2222 443	performance requirements 2222 444 to 447
<p>$\Delta C/C \leq 0,25\%$ of the value measured in A.3.1.</p>	<p>$\Delta C/C \leq 0,75\%$ of the value measured in A.3.1.</p>
<p>$\Delta C/C \leq 1\% + 0,5 \text{ pF}$ for $C_R \leq 1000 \text{ pF}$, $\leq 1\%$ for $C_R > 1000 \text{ pF}$ compared to values measured in A.4.1. As in GENERAL DATA of the specification or $\leq 1,4 \times$ value measured in A.4.1, whichever is greater. $\geq 50\%$ of values in GENERAL DATA of the specification.</p>	<p>Not applicable.</p>

additional test	D or ND	conditions of test (see Note 1)	performance requirements 2222 424 to 431
Sub-group ADD5			Not applicable.
A.5 Detergent resistance		Density 20g/l dishwasher detergent Temperature 70 °C, during 3 min. Followed by rinsing in clear water for 1 min. Recovery time > 2 h.	
A.5.1 Initial measurements		Capacitance for $C_R \leq 1000 \text{ pF}$ at 100 kHz, $C_R > 1000 \text{ pF}$ at 1 kHz Tangent of loss angle for $C_R \leq 1000 \text{ pF}$ at 1 MHz, $1000 \text{ pF} < C_R \leq 15\,000 \text{ pF}$ at 100 kHz, $C_R > 15\,000 \text{ pF}$ at 10 kHz	
A.5.2 Final measurements		Capacitance Tangent of loss angle Insulation resistance	

performance requirements
2222 443

performance requirements
2222 444 to 447

Not applicable.

$\Delta C/C \leq 1\% + 0,5 \text{ pF}$ for
 $C_R \leq 1000 \text{ pF}$,
 $\leq 1\%$ for $C_R > 1000 \text{ pF}$
 compared to values measured
 in A.5.1.
 As in GENERAL DATA of
 the specification or $\leq 1,4 \times$
 value measured in A.5.1,
 whichever is greater.
 $\geq 50\%$ of values in GENERAL
 DATA of the specification.

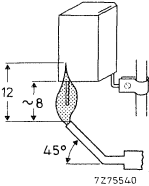
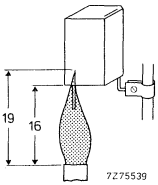
additional test	D or ND	conditions of test (see Note 1)	performance requirements 2222 424 to 431
<p>Sub-group ADD6</p> <p>A.6.1 Needle flame test IEC 695-2-2</p> <p>A.6.2 Needle flame test UL 1414</p>	<p>D</p>	<p>Bore of gas jet: ϕ 0,5 mm Fuel: butane Test duration: 20 s One flame application</p>  <p>7275540</p> <p>Bore of gas jet: ϕ 10 mm Fuel: natural gas Test duration: 3 x 15 s. Time interval between each flame application: 15 s.</p>  <p>7275539</p>	<p>Not applicable.</p>
<p>Sub-group ADD7</p> <p>A.7 Climatic test on taped type</p>		<p>250 h at 40 ± 2 °C R.H. 90 to 95% Recovery time 24 h.</p>	<p>Deviation of tape on a strip of 250 mm taped products \leq 2%. Pull out and tearing forces \geq 50% of values in GENERAL DATA of this specification.</p>

performance requirements
2222 443

performance requirements
2222 444 to 447

After removing the test flame from the capacitor, the capacitor must not continue to burn for more than 15 s, no burning particles must drop from the sample.

Not applicable.

Extinguishing time
 ≤ 15 s after the first and second flame application,
 ≤ 60 s after the third flame application.

Not applicable.

Not applicable.

POLYPROPYLENE FILM/FOIL CAPACITORS
(KP)

POLYPROPYLENE FILM/FOIL CAPACITORS

KP radial potted type

- 15, 22,5 and 27,5 mm pitch
- Supplied in boxes

QUICK REFERENCE DATA

Rated capacitance range (E12-series)	0,039 to 0,82 μ F
Tolerance on rated capacitance	$\pm 10\%$, $\pm 5\%$
Rated voltage U_R (d.c.)	250 V
Climatic category	55/085/56
Rated temperature	85 $^{\circ}$ C
Related specification	IEC 384-13
Stability class	3

STYLE



Style 2222 357 5 ; see Table 1.

APPLICATION

These capacitors are for applications where high currents and steep pulses occur. They are mainly used for deflection circuits in television receivers, to operate at high peak currents at line frequency. When requiring advice, please send oscillograms of current and voltage waveforms.

DESCRIPTION

The capacitors consist of an impregnated, low-inductance wound cell of aluminium foil and polypropylene film. The cell is potted with epoxy resin in a yellow flame-retardent polypropylene case. The radial leads are solder-coated copper wire.

The capacitors can withstand solvents and rinsing liquids without damage. They are provided with small stand-off pips to allow removal of solder flux etc., when cleaning the printed-wiring board.

GENERAL DATA

Dimensions in mm

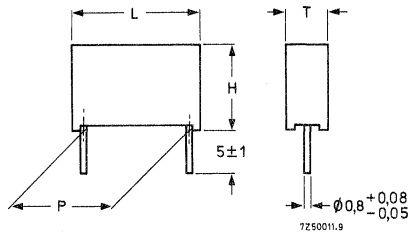

Fig. 1.

Table 1 U_R (d.c.) = 250 V; max. a.c. voltage = 160 V; Fig. 1

rated capacitance μF	T_{max}	H_{max}	L_{max}	P	mass g	catalogue number 2222 357	
						tol. $\pm 10\%$	tol. $\pm 5\%$
0,039	8	15	21,5	$15 \pm 0,4$	3	51393	52393
0,047	8	15			3	51473	52473
0,056	8	15			3	51563	52563
0,068	10	17			4,5	51683	52683
0,082	10	17			4,5	51823	52823
0,10	8,5	18,5	29	$22,5 \pm 0,4$	5,5	51104	52104
0,12	8,5	18,5			5,5	51124	52124
0,15	8,5	18,5			5,5	51154	52154
0,18	8,5	18,5			5,5	51184	52184
0,22	10	20	34	$27,5 \pm 0,4$	8,5	51224	52224
0,27	10	20			8,5	51274	52274
0,33	12	22			11	51334	52334
0,39	12	22			11	51394	52394
0,47	15	25			16	51474	52474
0,56	15	25			16	51564	52564
0,68	15	25			16	51684	52684
0,82	18	28			22	51824	52824

Marking

- a. Rated capacitance
- b. Rated voltage
- c. Tolerance on rated capacitance
- d. Category voltage
- e. Year and month of manufacture
- f. Manufacturer's name
- g. Climatic category
- h. Manufacturer's type designation

The capacitors are marked on the top by embossed print with a, b, c, e, f and h as follows:

1st line : rated capacitance in μF , tolerance and rated d.c. voltage;

2nd line : code for dielectric material, 5th, 6th and 7th digits of the catalogue number, code for factory of origin, production date code according to IEC 62, clause 5.

The manufacturer's identification symbol is indicated at the left.

The package containing the capacitors is marked with a to h.

Mounting

The capacitors are suited for mounting on printed-wiring boards.

Ratings and characteristics

Unless otherwise specified all electrical values apply to an ambient free air temperature of $23 \pm 1 \text{ }^\circ\text{C}$, an atmospheric pressure of 86 to 106 kPa and a relative humidity of $50 \pm 2\%$.

Capacitance

Rated capacitance range at 1 kHz

see Table 1

Tolerance on rated capacitance

see Table 1

Frequency dependence between 100 Hz and 100 kHz

negligible

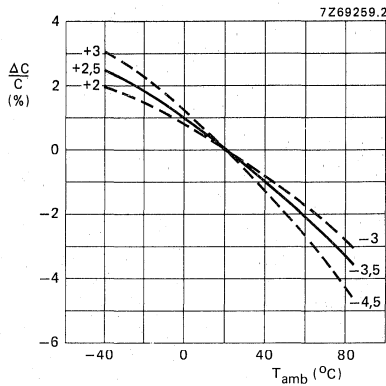

Fig. 2 Capacitance as a function of ambient free air temperature, typical curve.

Voltage

Rated voltage U_R (d.c.)

250 V

Maximum a.c. voltage (r.m.s. value), at 50 to 60 Hz

160 V

Test voltage

between terminations

$2 \times U_R$ (d.c.)

between interconnected terminations and case

1000 V (d.c.)

Notes

- The sum of the d.c. voltage and the peak value of the superimposed a.c. voltage must be $\leq U_R$ (d.c.).
- For waveforms other than sinusoidal the maximum permissible dissipation must not be exceeded.

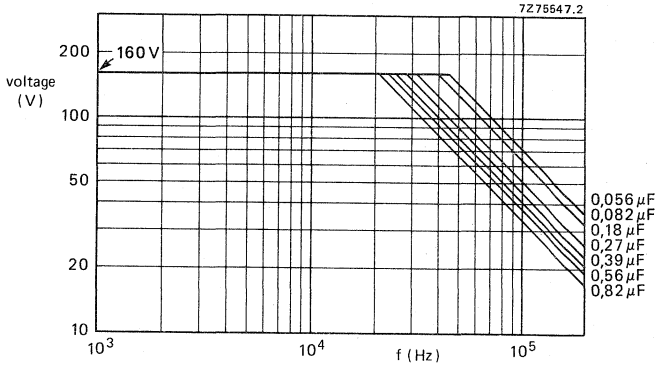

Fig. 3 Maximum a.c. voltage (r.m.s. value) as a function of frequency at $T_{amb} \leq 45 \text{ }^\circ\text{C}$.

Temperature

Climatic category	55/085/56
Rated temperature	85 °C
Storage temperature range	-55 to + 85 °C

Rated voltage pulse slope $(\frac{dU}{dt})R$ limited by network conditions

Tangent of loss angle at 100 kHz

15 and 22,5 mm pitch	$\leq 15 \times 10^{-4}$
27,5 mm pitch	
$C_R \leq 0,33 \text{ } \mu\text{F}$	$\leq 15 \times 10^{-4}$
$0,33 < C_R \leq 0,47 \text{ } \mu\text{F}$	$\leq 20 \times 10^{-4}$
$C_R > 0,47 \text{ } \mu\text{F}$	$\leq 25 \times 10^{-4}$

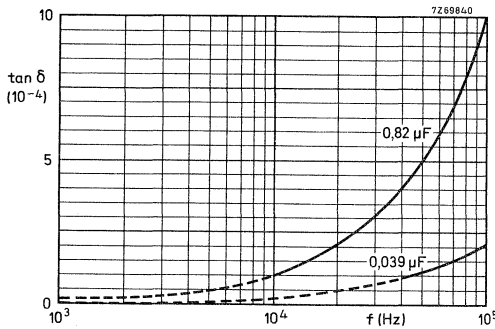

Fig. 4 $\tan \delta$ as a function of frequency; typical curves.

Insulation resistance

The insulation resistance is measured after a voltage of 100 ± 15 V has been applied for $1 \text{ min} \pm 5 \text{ s}$, at $T_{\text{amb}} = 23 \text{ }^\circ\text{C}$.

R between terminations

$C_R \leq 0,1 \text{ } \mu\text{F}$

$C_R > 0,1 \text{ } \mu\text{F}$

$> 50\,000 \text{ M}\Omega$

$> 5\,000 \text{ s}$

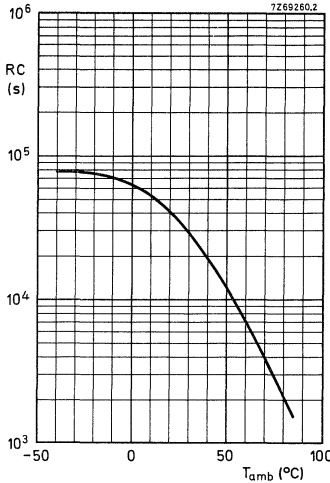

Fig. 5 RC-product as a function of ambient free air temperature; typical curve.

Maximum dissipation

The maximum a.c. voltage, which has been specified at 50 to 60 Hz must also never be exceeded at other frequencies.* Moreover this voltage may further be limited by the maximum dissipation (P_{max}).

For a capacitor used with sinusoidal voltage, the power dissipation is expressed by:

$$P = V_{\text{rms}} I_{\text{rms}} \cos \varphi \tag{1}$$

As $I_{\text{rms}} = \omega C V_{\text{rms}}$, and $\cos \varphi \approx \tan \delta$, equation (1) can be rewritten as:

$$P = V_{\text{rms}}^2 \omega C \tan \delta = V_{\text{rms}}^2 2\pi f C \tan \delta. \tag{2}$$

For capacitors of style 2222 357 5 , $\tan \delta$ is about proportional to the frequency, thus:

$$\tan \delta = \frac{f}{10^5} \tan \delta_{\text{ref}}. \tag{3}$$

$\tan \delta_{\text{ref}}$ is the maximum $\tan \delta$ at 100 kHz value given under Ratings and characteristics.

Substituting equation (3) in equation (2) gives:

$$P = 2\pi \cdot 10^{-5} V_{\text{rms}}^2 f^2 C \tan \delta_{\text{ref}}. \tag{4}$$

The maximum dissipation (P_{max}), which depends on the dimensions of the capacitor and on the ambient free air temperature, can be found from Fig. 6.

* At $T_{\text{amb}} \leq 45 \text{ }^\circ\text{C}$ the maximum permissible sinusoidal voltage can be found in Fig. 3.

curve	dimensions (mm)		
	T _{max}	H _{max}	L _{max}
1	8	15	21,5
2	10	17	21,5
3	8,5	18,5	29
4	10	20	29
5	10	20	34
6	12	22	34
7	15	25	34
8	18	28	34

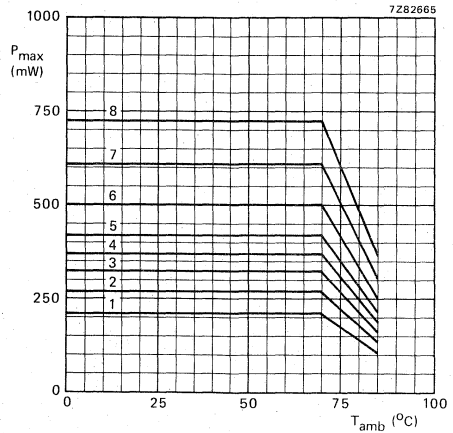

Fig. 6 Maximum dissipation as a function of ambient free air temperature, at various capacitor dimensions.

ORDERING INFORMATION

Order the capacitors by quoting the 12-digit catalogue number as given in Table 1.

PACKING

The capacitors are supplied in cardboard boxes; the number per box is shown in the table below.

L _{max} mm	number of capacitors per box
21,5 or 29	200
34	100

POLYPROPYLENE FILM/FOIL CAPACITORS

KP axial sleeved type

- Supplied on bandoliers on reel or loose in boxes

QUICK REFERENCE DATA

Rated capacitance range	47 to 56 000 pF
Tolerance on rated capacitance	± 5% (E24-series) ± 2% (E24, E48-series)
Rated voltage U_R (d.c.)	63 V, 160 V, 250 V
Climatic category	40/100/21
Rated temperature	85 °C
Related specification	IEC 384-13
Stability class	1

SURVEY OF STYLES

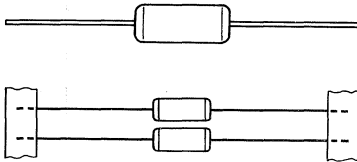

2222 455 to 2222 457 ;
see Tables 1 to 3.

APPLICATION

For use in circuits where close tolerance, reliability and low losses are of prime importance, e.g. tuned circuits, filter networks, timing networks, etc.

DESCRIPTION

The capacitors consist of a low-inductance wound cell of metal foil and a polypropylene film. The cell is covered with a blue plastic sleeve. The axial leads are of solder-coated wire.

GENERAL DATA

Dimensions in mm

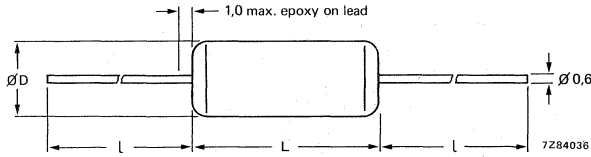

Fig. 1.

Table 1 U_R (d.c.) = 63 V; max. a.c. voltage = 40 V; Fig. 1.

rated capacitance (E24-series, tol. $\pm 5\%$)* pF	D_{max}	L_{max}	l_{min}	approx. mass g	catalogue number 2222 455			
					on bandoliers on reel	in box		
3 300	4,0	11,0	30	0,3	63302	23302		
3 600					63602	23602		
3 900					63902	23902		
4 300					64302	24302		
4 700					64702	24702		
5 100	4,5			15,0	28	0,4	65102	25102
5 600							65602	25602
6 200							66202	26202
6 800							66802	26802
7 500							67502	27502
8 200	5,0	15,0	28			0,5	68202	28202
9 100							69102	29102
10 000							61003	21003
11 000							61103	21103
12 000							61203	21203
13 000	5,5			15,0	28	0,6	61303	21303
15 000							61503	21503
16 000							61603	21603
18 000							61803	21803
20 000							62003	22003
22 000	6,0	15,0	28			0,7	62203	22203
24 000							62403	22403
27 000							62703	22703
30 000							63003	23003
33 000							63303	23303
36 000	6,5			15,0	28	0,8	63603	23603
39 000							63903	23903
43 000							64303	24303
47 000							64703	24703
51 000							65103	25103
56 000	8,0	15,0	28			1,0	65603	25603

* Besides the values of the E24-series with a tolerance $\pm 5\%$ as quoted, these values and intermediate values of the E48-series are available with a tolerance $\pm 2\%$.

Table 2 U_R (d.c.) = 160 V; max. a.c. voltage = 63 V; Fig. 1.

rated capacitance (E24-series, tol. $\pm 5\%$)* pF	D_{\max}	L_{\max}	l_{\min}	approx. mass g	catalogue number 2222 456					
					on bandoliers on reel	in box				
1 800	4,0	11,0	30	0,3	61802	21802				
2 000					62002	22002				
2 200					62202	22202				
2 400					62402	22402				
2 700					62702	22702				
3 000					63002	23002				
3 300					4,5	11,0	30	0,3	63302	23302
3 600									63602	23602
3 900									63902	23902
4 300									64302	24302
4 700	5,0	11,0	30	0,4	64702	24702				
5 100					65102	25102				
5 600					65602	25602				
6 200	4,5	15,0	28	0,5	66202	26202				
6 800					66802	26802				
7 500					67502	27502				
8 200					68202	28202				
9 100					69102	29102				
10 000	5,0	15,0	28	0,5	61003	21003				
11 000					61103	21103				
12 000					61203	21203				
13 000	5,5	15,0	28	0,6	61303	21303				
15 000					61503	21503				
16 000	6,0	15,0	28	0,6	61603	21603				
18 000					61803	21803				
20 000	6,5	15,0	28	0,7	62003	22003				
22 000					62203	22203				
24 000	7,0	15,0	28	0,8	62403	22403				
27 000					62703	22703				
30 000	7,5	15,0	28	0,9	63003	23003				
33 000					63303	23303				
36 000	8,0	15,0	28	1,0	63603	23603				

* Besides the values of the E24-series with a tolerance $\pm 5\%$ as quoted, these values and intermediate values of the E48-series are available with a tolerance $\pm 2\%$.

Table 3 U_R (d.c.) = 250 V; max. a.c. voltage = 125 V; Fig. 1.

rated capacitance (E24-series, tol. $\pm 5\%$)* pF	D_{max}	L_{max}	I_{min}	approx. mass g	catalogue number 2222 457	
					on bandoliers on reel	in box
47	4,0				64709	24709
51					65109	25109
56					65609	25609
62					66209	26209
68					66809	26809
75					67509	27509
82					68209	28209
91					69109	29109
100					61001	21001
110					61101	21101
120					61201	21201
130					61301	21301
150					61501	21501
160					61601	21601
180					61801	21801
200					62001	22001
220					62201	22201
240					62401	22401
270					62701	22701
300					63001	23001
330	11,0	30	0,3	63301	23301	
360				63601	23601	
390				63901	23901	
430				64301	24301	
470				64701	24701	
510				65101	25101	
560				65601	25601	
620				66201	26201	
680				66801	26801	
750				67501	27501	
820	68201	28201				
910	69101	29101				
1 000	4,5			61002	21002	
1 100				61102	21102	
1 200				61202	21202	
1 300				61302	21302	
1 500				61502	21502	
1 600				61602	21602	
1 800				61802	21802	
2 000				62002	22002	
2 200				62202	22202	
2 400				5,0		0,4
2 700	62702	22702				
3 000	63002	23002				

* Besides the values of the E24-series with a tolerance $\pm 5\%$ as quoted, these values and intermediate values of the E48-series are available with a tolerance $\pm 2\%$.

Table 3 (continued) U_R (d.c.) = 250 V; max. a.c. voltage = 125 V; Fig. 1.

rated capacitance (E24-series, tol. $\pm 5\%$)* pF	D_{max}	L_{max}	l_{min}	approx. mass g	catalogue number 2222 457	
					on bandoliers on reel	in box
3 300	4,5	15,0	28	0,4	63302	23302
3 600					63602	23602
3 900					63902	23902
4 300					64302	24302
4 700					64702	24702
5 100	5,0			0,5	65102	25102
5 600	65602				25602	
6 200	66202				26202	
6 800	5,5				66802	26802
7 500	67502				27502	
8 200	6,0	68202	28202			
9 100	6,5	69102	29102			
10 000	7,0	61003	21003			
11 000	7,5	61103	21103			
12 000	8,0	61203	21203			
13 000		61303	21303			
15 000		61503	21503			
16 000		61603	21603			
18 000		61803	21803			
20 000		62003	22003			

Marking

The capacitors are marked in black ink as follows:

1st line : rated capacitance in pF or nF;

2nd line : tolerance code (G = $\pm 2\%$, J = $\pm 5\%$) and rated voltage (d.c.) without unit symbol;

3rd line : code for dielectric material (KP = polypropylene film/foil) and production date code (according to IEC 62, clause 5);

4th line : name of manufacturer.

Mounting

The capacitors are suited for vertical or horizontal mounting on printed-wiring boards and for point-to-point wiring.

The capacitors packed on bandoliers are for mounting with automatic insertion machines.

* Besides the values of the E24-series with a tolerance $\pm 5\%$ as quoted, these values and intermediate values of the E48-series are available with a tolerance $\pm 2\%$.

Ratings and characteristics

Unless otherwise specified all electrical values apply to an ambient free air temperature of $23 \pm 1 \text{ }^\circ\text{C}$, an atmospheric pressure of 86 to 106 kPa and a relative humidity of $50 \pm 2\%$.

Capacitance

Rated capacitance range

at 1 MHz ($C_R \leq 1000 \text{ pF}$)

at 1 kHz ($C_R > 1000 \text{ pF}$)

Tolerance on rated capacitance

Temperature coefficient

Frequency dependence between 100 kHz and 1 MHz

see Tables 1 to 3

see Tables 1 to 3

$\pm 5\%$, $\pm 2\%$ or $\pm 2 \text{ pF}^*$

$-(250 \pm 120) 10^{-6}/\text{K}$

none

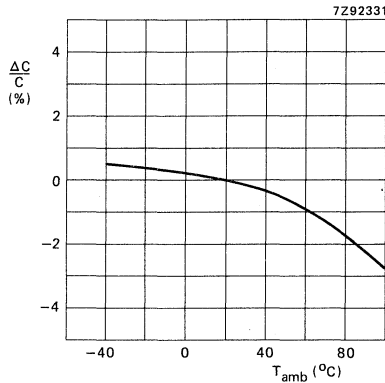

Fig. 2 Capacitance as a function of ambient free air temperature; typical curve.

Voltage

Rated voltage U_R (d.c.)

see Tables 1 to 3

Category voltage U_C

$0,8 \times U_R$ (d.c.)

Test voltage

between terminations

$2 \times U_R$ (d.c.)

between interconnected terminations and case

$2 \times U_R$ (d.c.); min. 400 V

Maximum a.c. voltage (r.m.s. value) at 50 to 60 Hz

40 V, 63 V, 100 V

Notes

- The sum of the d.c. voltage and the peak value of the superimposed a.c. voltage must be $\leq U_R$ (d.c.).
- For other than sinusoidal waveforms, the maximum permissible dissipation must not be exceeded.

* Whichever is greater.

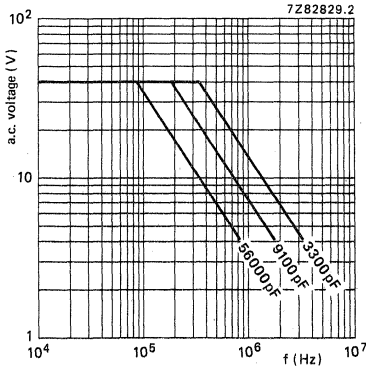

Fig. 3 Maximum a.c. voltage (r.m.s. value) as a function of frequency at $T_{amb} \leq 70^\circ C$, for $U_R = 63 V$.

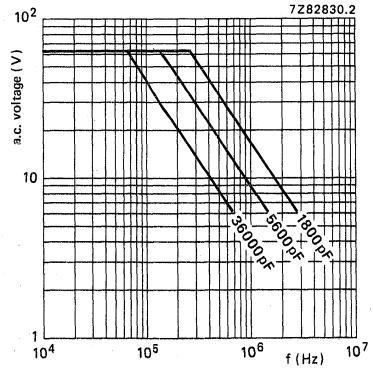

Fig. 4 Maximum a.c. voltage (r.m.s. value) as a function of frequency at $T_{amb} \leq 70^\circ C$, for $U_R = 160 V$.

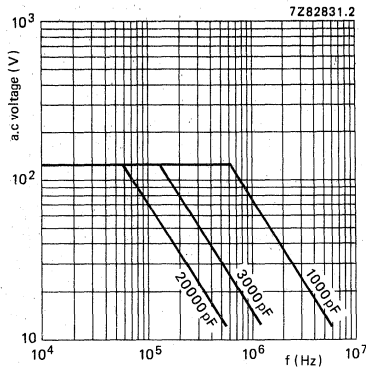

Fig. 5 Maximum a.c. voltage (r.m.s. value) as a function of frequency at $T_{amb} \leq 70^\circ C$, for $U_R = 250 V$.

Temperature

Climatic category

40/100/21

Rated temperature

85 °C

Storage temperature range

-40 to + 100 °C

Tangent of loss angle

Table 4

capacitance	tangent of loss angle		
	at 1 kHz	at 100 kHz	at 1 MHz
$C_R \leq 1000 \text{ pF}$	$\leq 5 \times 10^{-4}$		$\leq 10 \times 10^{-4}$
$1000 \text{ pF} < C_R \leq 5000 \text{ pF}$	$\leq 5 \times 10^{-4}$	$\leq 10 \times 10^{-4}$	
$5000 \text{ pF} < C_R \leq 20\,000 \text{ pF}$	$\leq 5 \times 10^{-4}$	$\leq 15 \times 10^{-4}$	
$C_R > 20\,000 \text{ pF}$	$\leq 5 \times 10^{-4}$	$\leq 25 \times 10^{-4}$	

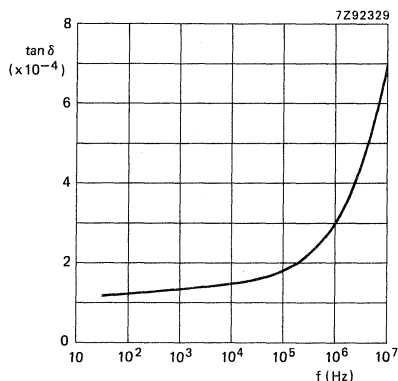

Fig. 6 $\tan \delta$ as a function of frequency; typical curve.

Insulation resistance at $T_{amb} = 20 \text{ }^\circ\text{C}$

The insulation resistance is measured after a voltage has been applied for $1 \text{ min} \pm 5 \text{ s}$, the voltage being $10 \pm 1 \text{ V}$ for the 63 V version, $100 \pm 15 \text{ V}$ for the 160 V and 250 V versions.

R between terminations $> 100\,000 \text{ M}\Omega$

R between interconnected terminations and case $> 100\,000 \text{ M}\Omega$

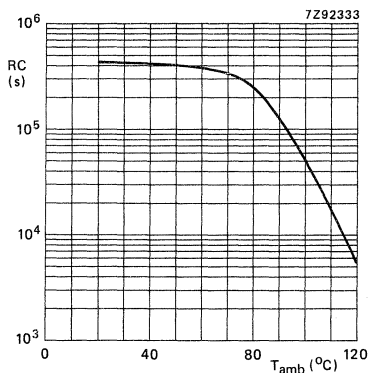

Fig. 7 RC-product as a function of ambient free air temperature; typical curve.

Inductance

$\leq 10 \text{ nH/cm}$ lead and capacitor length

Maximum dissipation

The maximum a.c. voltage, which has been specified at 50 to 60 Hz must also never be exceeded at other frequencies.* Moreover this voltage may further be limited by the maximum dissipation (P_{max}).

For a capacitor used with a sinusoidal voltage, the power dissipation is expressed by:

$$P = V_{rms} I_{rms} \cos \varphi. \tag{1}$$

As $I_{rms} = \omega C V_{rms}$, and $\cos \varphi \approx \tan \delta$, equation (1) can be rewritten as:

$$P = V_{rms}^2 \omega C \tan \delta = V_{rms}^2 2\pi f C \tan \delta. \tag{2}$$

For capacitors of styles 2222 455, 2222 456 and 2222 457 $\tan \delta$ is about proportional to the frequency, thus:

$$\tan \delta = \frac{f}{10^5} \tan \delta_{ref} \tag{3}$$

$\tan \delta_{ref}$ is the maximum $\tan \delta$ at 100 kHz value given under Ratings and characteristics.

Substituting equation (3) in equation (2) gives:

$$P = 2\pi \cdot 10^{-5} V_{rms}^2 f^2 C \tan \delta_{ref}. \tag{4}$$

The maximum dissipation (P_{max}), which depends on the dimensions of the capacitor and on the ambient free air temperature, can be found from Fig. 8.

Table 5

curve	dimensions (mm)	
	D_{max}	L_{max}
1	4,0	11,0
2	4,5	11,0
3	5,0	11,0
4	4,5	15,0
5	5,0	15,0
6	5,5	15,0
7	6,0	15,0
8	6,5	15,0
9	7,0	15,0
10	7,5	15,0
11	8,0	15,0

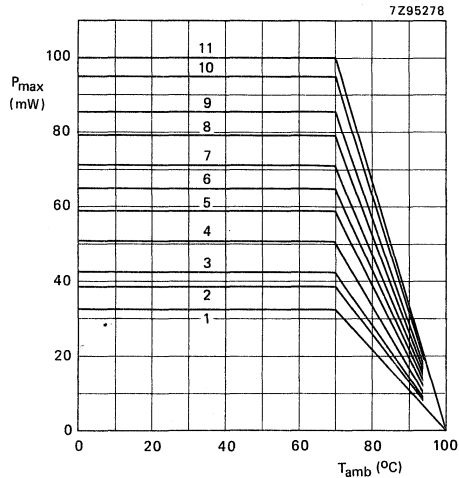

Fig. 8 Maximum dissipation as a function of ambient free air temperature.

* At $T_{amb} \leq 70 \text{ }^\circ\text{C}$ the maximum permissible sinusoidal voltage can be found in Figs 3, 4 and 5.

ORDERING INFORMATION

Order the capacitors by quoting the 12-digit catalogue number.

Composition of the catalogue number (see also Tables 1 to 3).

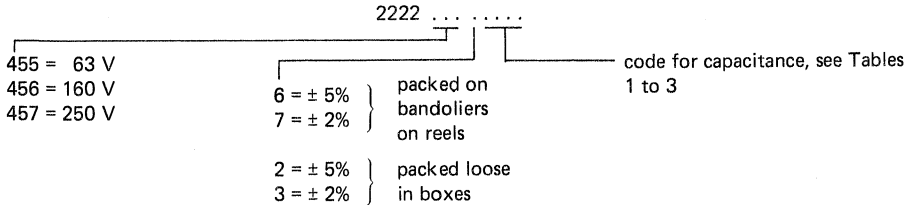

PACKING

The capacitors are supplied on bandoliers on reels or loose in cardboard boxes.

Packing in cardboard boxes

Table 6

capacitance values (pF) of			number of capacitors per box
63 V version	160 V version	250 V version	
3 300- 4 300	1 800- 2 700	47- 620	400
4 700- 6 200	3 000- 3 900	680- 2 200	300
6 800- 9 100	4 300- 5 600	2 400- 3 000	250
10 000-12 000	6 200- 7 500	3 300- 4 300	400
13 000-16 000	8 200-10 000	4 700- 5 600	300
18 000-27000	11 000-16 000	6 200- 9 100	250
30 000-33 000	18 000-20 000	10 000-11 000	200
36 000-56 000	22 000-36 000	12 000-20 000	150

Packing on bandoliers on reels

Dimensions in mm

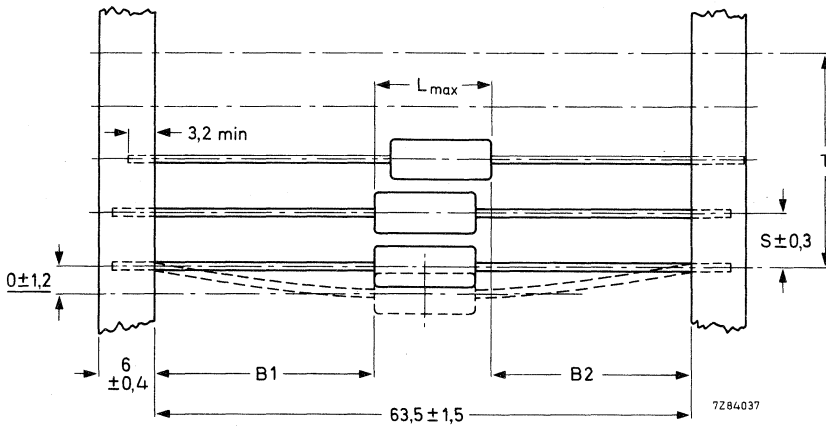

Fig. 9 Capacitors on bandoliers; for dimensions S and T, see Table 7.
|B1 - B2| = max. 1,4 mm; for dimension L_{max}, see Tables 1 to 3.

Table 7

capacitance values (pF) of			S	T for number (n) of capacitors	
63 V version	160 V version	250 V version		n < 50	50 < n < 100
3 300— 6 200	1 800— 3 900	47— 2 200	5	5(n-1) ± 2	5(n-1) ± 4
6 800— 9 100	4 300— 5 600	2 400— 3 000	10	10(n-1) ± 2	10(n-1) ± 4
10 000—12 000	6 200— 7 500	3 300— 4 300	5	5(n-1) ± 2	5(n-1) ± 4
13 000—56 000	8 200—36 000	4 700—20 000	10	10(n-1) ± 2	10(n-1) ± 4

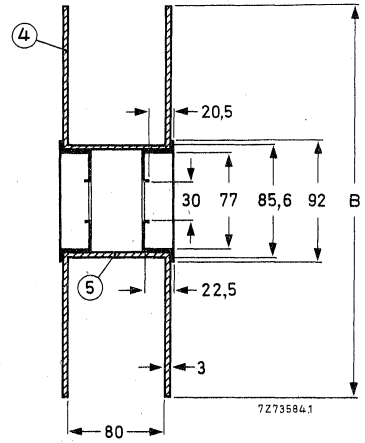
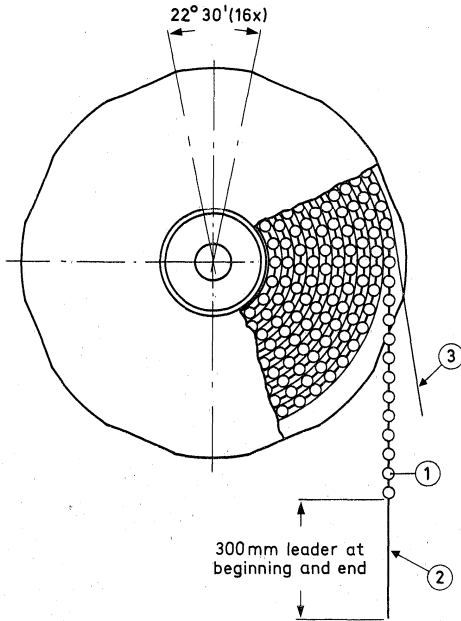

Fig. 10 Reel; for dimension B, see Table 8.

Table 8

capacitance values (pF) of			B	number of capacitors on one reel
63 V version	160 V version	250 V version		
3 300— 6 200	1 800— 3 900	47— 2 200	305	2500
6 800— 9 100	4 300— 5 600	2 400— 3 000	356	1500
10 000—12 000	6 200— 7 500	3 300— 4 300	305	2500
13 000—27 000	8 200—16 000	4 700— 9 100	356	1500
30 000—56 000	18 000—36 000	10 000—20 000	356	1000

Characteristics concerning taped capacitors:

Pull-out force of the component

≥ 2 N

Tearing force of tape

≥ 10 N

Storage conditions:

Storage temperature range

−25 to + 40 °C

Relative humidity

≤ 80%

POLYPROPYLENE FILM/FOIL CAPACITORS

KP axial epoxy lacquered type

- Supplied on bandoliers on reel or loose in boxes

QUICK REFERENCE DATA

Rated capacitance range	47 to 62 000 pF
Tolerance on rated capacitance	± 5% (E24-series) ± 2% (E24, E48-series) ± 1% (E24, E48, E96-series)
Rated voltage U_R (d.c.)	63 V, 160 V, 250 V
Climatic category	40/100/56
Rated temperature	85 °C
Related specification	IEC 384-13
Stability class	2

SURVEY OF STYLES

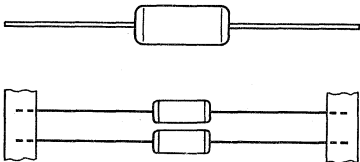

2222 460 to 2222 462;
see Tables 1 to 3.

APPLICATION

For use in circuits where close tolerance, reliability and low losses are of prime importance, e.g. tuned circuits, filter networks, timing networks, etc.

DESCRIPTION

The capacitors consist of a low-inductance wound cell of metal foil and a polypropylene film. The cell is protected by a hard water repellent solvent resistant blue epoxy lacquer. The long axial leads of solder-coated wire make the capacitors suitable for vertical or horizontal mounting on printed-wiring boards.

GENERAL DATA

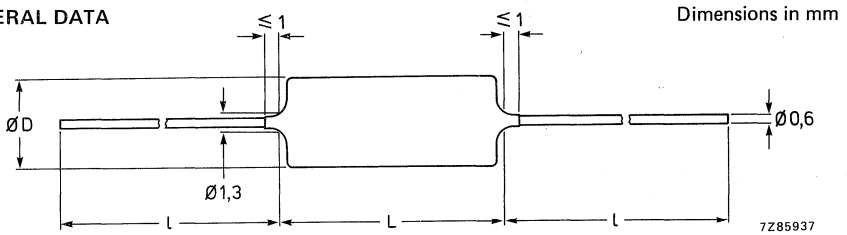

Fig. 1.

Table 1 U_R (d.c.) = 63 V; max. a.c. voltage = 40 V; Fig. 1.

rated capacitance (E24-series, tol. $\pm 5\%$) * pF	D_{max}	L_{max}	l_{min}	approx. mass g	catalogue number 2222 460	
					on bandoliers on reel	in box
6 800	5,0	11,0	30	0,5	66802	26802
7 500				67502	27502	
8 200				68202	28202	
9 100				69102	29102	
10 000				61003	21003	
11 000				61103	21103	
12 000				61203	21203	
13 000				61303	21303	
15 000				61503	21503	
16 000				61603	21603	
18 000	15,0	28	0,8	61803	21803	
20 000			0,8	62003	22003	
22 000			0,9	62203	22203	
24 000			0,9	62403	22403	
27 000			6,0	1,0	62703	22703
30 000			6,5	1,1	63003	23003
33 000				1,2	63303	23303
36 000				1,2	63603	23603
39 000				1,3	63903	23903
43 000			7,0	1,4	64303	24303
47 000	1,5	64703		24703		
51 000	1,6	65103		25103		
56 000	1,7	65603		25603		
62 000	8,0	1,8	66203	26203		

* Besides the values of the E24-series as quoted, intermediate values of the E-48-series (with a tolerance $\pm 1\%$ or $\pm 2\%$) and of the E96-series (with a tolerance $\pm 1\%$) are available.
See also Ordering information.

Table 2 U_R (d.c.) = 160 V; max. a.c. voltage = 63 V; Fig. 1.

rated capacitance (E24-series, tol. \pm 5%) * μ F	D_{max}	L_{max}	l_{min}	approx mass g	catalogue number 2222 461				
					on bandoliers on reel	in box			
3 600	5,0	11,0	30	0,5	63602	23602			
3 900				0,5	63902	23902			
4 300				0,5	64302	24302			
4 700				0,5	64702	24702			
5 100				0,5	65102	25102			
5 600				0,5	65602	25602			
6 200				0,6	66202	26202			
6 800				0,4	66802	26802			
7 500				0,7	67502	27502			
8 200				0,6	68202	28202			
9 100	5,5			0,6	69102	29102			
10 000				0,7	61003	21003			
11 000				0,7	61103	21103			
12 000				0,7	61203	21203			
13 000				0,8	61303	21303			
15 000				0,8	61503	21503			
16 000				6,0	15,0	28	0,9	61603	21603
18 000							0,9	61803	21803
20 000				1,0			62003	22003	
22 000				6,5			1,1	62203	22203
24 000	1,1	62403	22403						
27 000	7,0	62703	22703						
30 000	7,5	1,3	63003	23003					
33 000		1,4	63303	23303					
36 000	8,0	1,5	63603	23603					
39 000		1,6	63903	23903					

* Besides the values of the E24-series as quoted, intermediate values of the E48-series (with a tolerance \pm 1% or \pm 2%) and of the E96-series (with a tolerance \pm 1%) are available.
See also Ordering information.

Table 3 U_R (d.c.) = 250 V; max. a.c. voltage = 125 V; Fig. 1.

rated capacitance (E24-series, tol. $\pm 5\%$) * pF	D_{max}	L_{max}	I_{min}	approx. mass g	catalogue number 2222 462	
					on bandoliers on reel	in box
47				0,4	64709	24709
51				0,4	65109	25109
56				0,4	65609	25609
62				0,4	66209	26209
68				0,4	66809	26809
75				0,4	67509	27509
82				0,4	68209	28209
91				0,4	69109	29109
100				0,4	61001	21001
110				0,4	61101	21101
120				0,5	61201	21201
130				0,5	61301	21301
150				0,4	61501	21501
160				0,4	61601	21601
180				0,5	61801	21801
200				0,5	62001	22001
220				0,6	62201	22201
240				0,6	62401	22401
270				0,6	62701	22701
300				0,7	63001	23001
330				0,4	63301	23301
360				0,4	63601	23601
390	5,0	11,0	30	0,5	63901	23901
430				0,5	64301	24301
470				0,5	64701	24701
510				0,5	65101	25101
560				0,5	65601	25601
620				0,5	66201	26201
680				0,5	66801	26801
750				0,5	67501	27501
820				0,5	68201	28201
910				0,5	69101	29101
1000				0,5	61002	21002
1100				0,5	61102	21102
1200				0,5	61202	21202
1300				0,5	61302	21302
1500				0,4	61502	21502
1600				0,5	61602	21602
1800				0,6	61802	21802
2000				0,6	62002	22002

* Besides the values of the E24-series as quoted, intermediate values of the E48-series (with a tolerance $\pm 1\%$ or $\pm 2\%$) and of the E96-series (with a tolerance $\pm 1\%$) are available.
See also Ordering information.

Table 3 (continued) U_R (d.c.) = 250 V; max. a.c. voltage = 125 V; Fig. 1.

rated capacitance (E24-series, tol. $\pm 5\%$)* pF	D_{\max}	L_{\max}	l_{\min}	approx. mass g	catalogue number 2222 462	
					on bandoliers on reel	in box
2 200	5,0	11,0	30	0,	62202	22202
2 400				0,5	62402	22402
2 700				0,5	62702	22702
3 000				0,5	63002	23002
3 300				0,5	63302	23302
3 600				0,5	63602	23602
3 900				0,5	63902	23902
4 300				0,6	64302	24302
4 700				0,6	64702	24702
5 100				5,5	15,0	28
5 600	0,6	65602	25602			
6 200	0,7	66202	26202			
6 800	0,7	66802	26802			
7 500	0,7	67502	27502			
8 200	0,8	68202	28202			
9 100	0,8	69102	29102			
10 000	0,9	61003	21003			
11 000	0,9	61103	21103			
12 000	1,0	61203	21203			
13 000	1,0	61303	21303			
15 000	1,1	61503	21503			
16 000	1,2	61603	21603			
18 000	1,3	61803	21803			
20 000	1,4	62003	22003			
22 000	1,5	62203	22203			

Marking

The capacitors are marked in black ink as follows:

1st line: rated capacitance in pF or nF;

2nd line: tolerance code (F = $\pm 1\%$, G = $\pm 2\%$, J = $\pm 5\%$) and rated voltage (d.c.) without unit symbol;

3rd line: code for dielectric material (KP = polypropylene film/foil) and production date code (according to IEC 62, clause 5);

4th line: name of manufacturer.

Mounting

The capacitors are suited for vertical or horizontal mounting on printed-wiring boards and for point-to-point wiring.

The capacitors packed on bandoliers are for mounting with automatic insertion machines.

* Besides the values of the E24-series as quoted, intermediate values of the E48-series (with a tolerance $\pm 1\%$ or $\pm 2\%$) and of the E96-series (with a tolerance $\pm 1\%$) are available.

See also Ordering information.

Ratings and characteristics

Unless otherwise specified all electrical values apply to an ambient free air temperature of $23 \pm 1 \text{ }^\circ\text{C}$, an atmospheric pressure of 86 to 106 kPa and a relative humidity of $50 \pm 2\%$.

Capacitance

Rated capacitance range
at 1 MHz ($C_R \leq 1000 \text{ pF}$)
at 1 kHz ($C_R > 1000 \text{ pF}$)

see Tables 1 to 3

Tolerance on rated capacitance

$\pm 5\%$, $\pm 2\%$ or 2 pF^* ,
 $\pm 1\%$ or 1 pF^*

Temperature coefficient
between -40 and $+20 \text{ }^\circ\text{C}$
between $+20$ and $+100 \text{ }^\circ\text{C}$

$-(125 \pm 60) 10^{-6}/\text{K}$
 $-(250 \pm 120) 10^{-6}/\text{K}$

Frequency dependence between 100 kHz and 1 MHz

none

Fig. 2 Capacitance as a function of ambient free air temperature; typical curve.

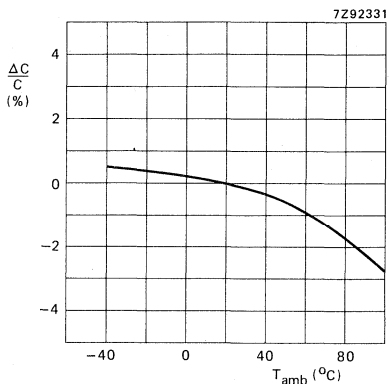

Voltage

Rated voltage U_R (d.c.)

see Tables 1 to 3

Category voltage U_C

$0,8 \times U_R$ (d.c.)

Test voltage

between terminations
between interconnected terminations
and case (foil method)

$2 \times U_R$ (d.c.)

$2 \times U_R$ (d.c.); min. 400 V

Maximum a.c. voltage (r.m.s. value) at 50 to 60 Hz

40 V, 63 V, 125 V

Notes

- The sum of the d.c. voltage and the peak value of the superimposed a.c. voltage must be $\leq U_R$ (d.c.).
- For other than sinusoidal waveforms, the maximum permissible dissipation must not be exceeded.

* Whichever is greater.

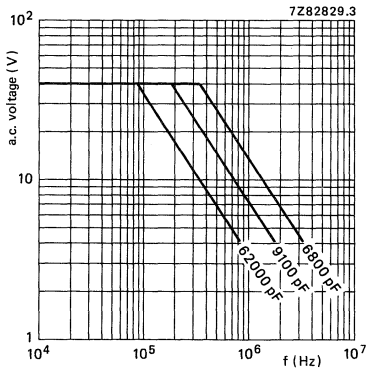

Fig. 3 Maximum a.c. voltage (r.m.s. value) as a function of frequency at $T_{amb} \leq 70^\circ\text{C}$, for $U_R = 63\text{ V}$.

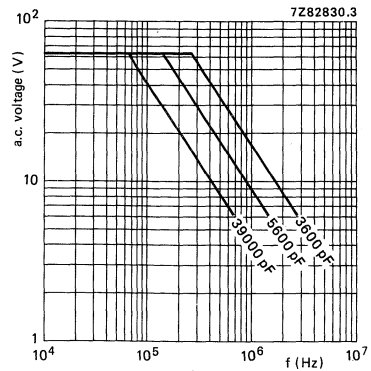
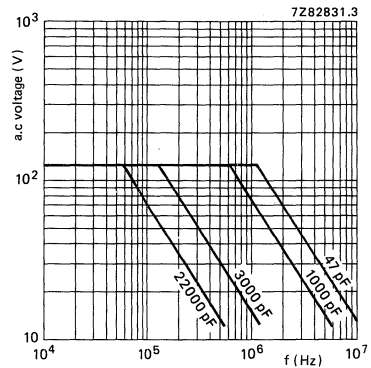

Fig. 4 Maximum a.c. voltage (r.m.s. value) as a function of frequency at $T_{amb} \leq 70^\circ\text{C}$, for $U_R = 160\text{ V}$.

Fig. 5 Maximum a.c. voltage (r.m.s. value) as a function of frequency at $T_{amb} \leq 70^\circ\text{C}$, for $U_R = 250\text{ V}$.



Temperature

Climatic category

Rated temperature

Storage temperature range

40/100/56

85 °C

-40 to + 100 °C

Tangent of loss angle

Table 4

capacitance	tangent of loss angle		
	at 1 kHz	at 100 kHz	at 1 MHz
$C_R \leq 1000 \text{ pF}$	$\leq 5 \times 10^{-4}$		$\leq 10 \times 10^{-4}$
$1000 \text{ pF} < C_R \leq 5000 \text{ pF}$	$\leq 5 \times 10^{-4}$	$\leq 10 \times 10^{-4}$	
$5000 \text{ pF} < C_R \leq 20\,000 \text{ pF}$	$\leq 5 \times 10^{-4}$	$\leq 15 \times 10^{-4}$	
$20\,000 \text{ pF} < C_R \leq 47\,000 \text{ pF}$	$\leq 5 \times 10^{-4}$	$\leq 25 \times 10^{-4}$	
$C_R > 47\,000 \text{ pF}$	$\leq 5 \times 10^{-4}$	$\leq 40 \times 10^{-4}$	

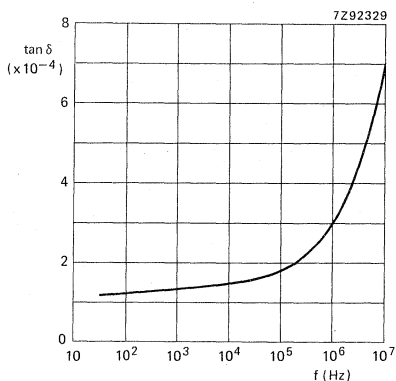

Fig. 6 Tan δ as a function of frequency; typical curve.

Insulation resistance at $T_{amb} = 20 \text{ }^\circ\text{C}$

The insulation resistance is measured after a voltage has been applied for $1 \text{ min} \pm 5 \text{ s}$, the voltage being $10 \pm 1 \text{ V}$ for the 63 V version, $100 \pm 15 \text{ V}$ for the 160 V and 250 V versions.

R between terminations $> 100\,000 \text{ M}\Omega$

R between interconnected terminations and case $> 100\,000 \text{ M}\Omega$

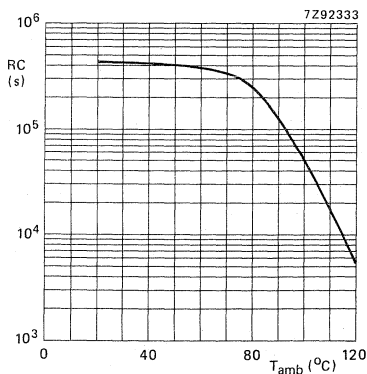

Fig. 7 RC-product as a function of ambient free air temperature; typical curve.

Inductance

$\leq 10 \text{ nH/cm}$ lead and capacitor length

Maximum dissipation

The maximum a.c. voltage, which has been specified at 50 to 60 Hz must also never be exceeded at other frequencies. * Moreover this voltage may further be limited by the maximum dissipation (P_{max}).

For a capacitor used with a sinusoidal voltage, the power dissipation is expressed by:

$$P = V_{rms} I_{rms} \cos \varphi. \tag{1}$$

As $I_{rms} = \omega CV_{rms}$, and $\cos \varphi \approx \tan \delta$, equation (1) can be rewritten as:

$$P = V_{rms}^2 \omega C \tan \delta = V_{rms}^2 2\pi f C \tan \delta. \tag{2}$$

For capacitors of styles 2222 460, 2222 461 and 2222 462, $\tan \delta$ is about proportional to the frequency, thus:

$$\tan \delta = \frac{f}{10^5} \tan \delta_{ref}. \tag{3}$$

$\tan \delta_{ref}$ is the maximum $\tan \delta$ at 100 kHz value given under Ratings and characteristics.

Substituting equation (3) in equation (2) gives:

$$P = 2\pi \cdot 10^{-5} V_{rms}^2 f^2 C \tan \delta_{ref}. \tag{4}$$

The maximum dissipation (P_{max}), which depends on the dimensions of the capacitor and on the ambient free air temperature, can be found from Fig. 8.

Table 5

curve	dimensions (mm)	
	D _{max}	L _{max}
1	5,0	11,0
2	5,5	15,0
3	6,0	15,0
4	6,5	15,0
5	7,0	15,0
6	7,5	15,0
7	8,0	15,0

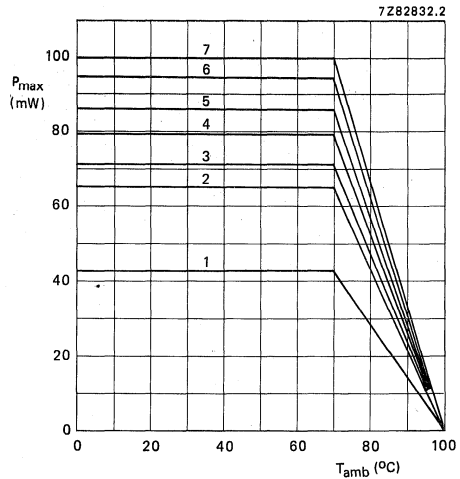

Fig. 8 Maximum dissipation as a function of ambient free air temperature.

* At $T_{amb} \leq 70^\circ C$ the maximum permissible sinusoidal voltage can be found in Figs 3, 4 and 5.

ORDERING INFORMATION

Order the capacitors by quoting the 12-digit catalogue number.

Composition of the catalogue number (see also Tables 1 to 3).

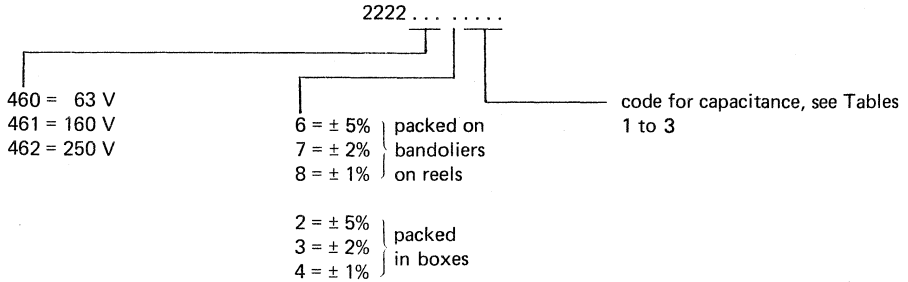

PACKING

The capacitors are supplied on bandoliers on reels or in cardboard boxes.

Packing in cardboard boxes

Table 6

63 V version	capacitance values (pF) of		number of capacitors per box
	160 V version	250 V version	
6 800 – 9 100	3 600 – 6 200	47 – 3 300	250
10 000 – 27 000	6 800 – 18 000	3 600 – 10 000	250
30 000 – 36 000	20 000 – 24 000	11 000 – 13 000	200
39 000 – 62 000	27 000 – 39 000	15 000 – 22 000	150

Packing on bandoliers on reels

Dimensions in mm

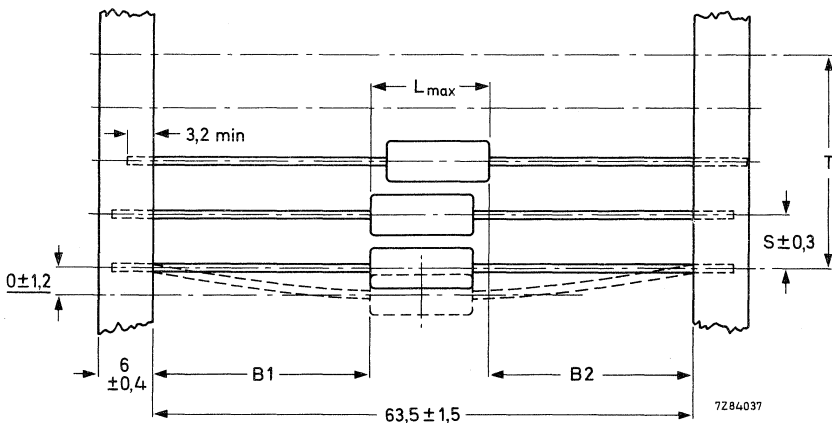

Fig. 9 Capacitors on bandoliers; for dimensions S and T, see Table 7.
|B1 - B2| = max. 1,4 mm; for dimension L_{max}, see Tables 1 to 3;

Table 7

capacitance values (pF) of			S	T for number (n) of capacitors	
63 V version	160 V version	250 V version		n < 50	50 < n < 100
6 800 – 62 000	3 600 – 39 000	47 – 22 000	10	10 (n - 1) ± 2	10 (n - 1) ± 4

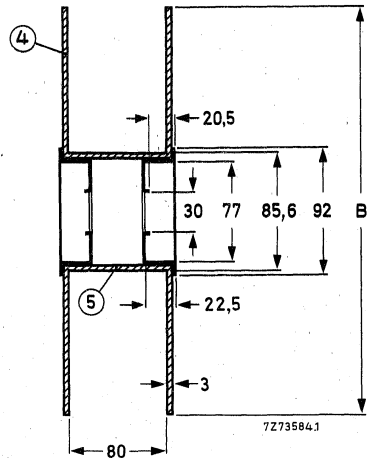
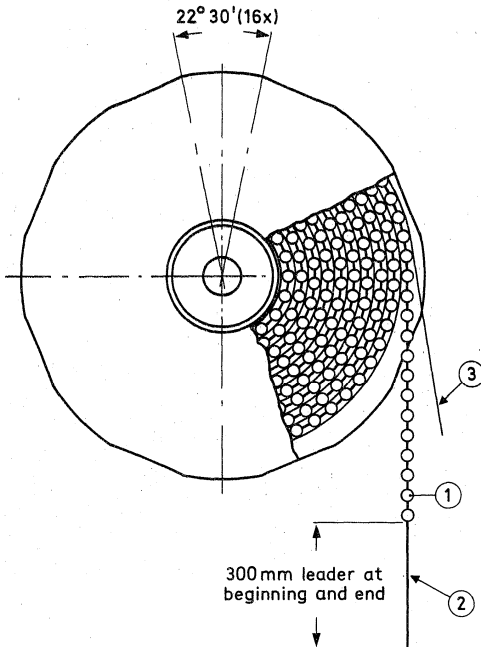

Fig. 10 Reel.

- 1: capacitor
- 2: bandolier
- 3: paper
- 4: flange
- 5: cylinder

Table 8

capacitance values (pF) of			B	number of capacitors on one reel
63 V version	160 V version	250 V version		
6 800 – 27 000	3 600 – 18 000	47 – 10 000	356	1500
30 000 – 62 000	20 000 – 39 000	11 000 – 22 000	356	1000

Characteristics concerning taped capacitors:

- Pull-out force of the component ≥ 2 N
- Tearing force of tape ≥ 10 N

Storage conditions:

- Storage temperature range -25 to $+40$ °C
- Relative humidity $\leq 80\%$

INSPECTION REQUIREMENTS

polypropylene film/foil capacitors (KP)

Note 1

Sub-clause numbers of tests and performance requirements refer to the Sectional Specification, IEC-publication 384-13 and GENERAL DATA of the specifications.

Note 2

In this table: D = destructive, ND = non-destructive.

Note 3

For the type ranges with CECC Qualification Approval separate periodic C-tests are carried out as prescribed by the CECC Detail specification.

clause number and test (see Note 1)	D or ND	conditions of test (see Note 1)	performance requirements 2222 357 5
Group A Inspection (lot-by-lot)			
Sub-group A1	ND		
4.1 Visual examination			No mechanical failures. Legible marking and as specified in GENERAL DATA of the specification.
4.2 Dimensions		Gauging	As specified in the Table in GENERAL DATA.
Sub-group A2	ND		
4.2.1 Voltage proof (Test A)		at $2 \times U_R$ (d.c.) for 1 s	No breakdown or flashover.
4.2.2 Capacitance		at 1 kHz	Within specified tolerance.
4.2.3 Tangent of loss angle		for $C_R \leq 1000$ pF	As in GENERAL DATA
		at 1 MHz,	of the specification.
		for $C_R > 1000$ pF	
		at 100 kHz	
4.2.4 Insulation resistance		at 100 V	As in GENERAL DATA
(Test A)			of the specification.

performance requirements
2222 455 – 457

performance requirements
2222 460 – 462

No mechanical failures.
Legible marking and as
specified in GENERAL DATA
of the specification.
As specified in the Tables
in GENERAL DATA.

No mechanical failures.
Legible marking and as
specified in GENERAL DATA
of the specification.
As specified in the Tables
in GENERAL DATA

No breakdown or flashover.
Within specified tolerance.
As in GENERAL DATA
of the specification.

No breakdown or flashover.
Within specified tolerance.
As in GENERAL DATA
of the specification.

Not applicable.

Not applicable.

sub-clause number and test (see Note 1)	D or ND	conditions of test (see Note 1)	performance requirements 2222 357 5. . . .
<p>Group B Inspection (periodic)</p> <p>4.5 Solderability</p>	D	<p>Without ageing Method: 1 Non-activated colophony flux Solder bath: 235 °C Dwell time: 2 s</p>	<p>Good tinning as evidenced by free flowing of the solder with wetting of the terminations.</p>
<p>Group C Inspection (periodic)</p> <p>Sub-group C1A Part of sample of Sub-group C1</p> <p>4.1 Dimensions (detail)</p> <p>4.3.1 Initial measurements</p> <p>4.3 Robustness of terminations</p> <p>4.4 Resistance to soldering heat</p> <p>4.4.2 Final measurements</p>	D	<p>Capacitance for $C_R \leq 1000$ pF at 100 kHz, $C_R > 1000$ pF at 1 kHz Tangent of loss angle for $C_R \leq 1000$ pF at 1 MHz, $C_R > 1000$ pF at 100 kHz</p> <p>Tensile, bending and torsion</p> <p>No predrying Method: 1A Solder bath: 260 °C Duration: 5 s</p> <p>Visual examination</p> <p>Capacitance</p>	<p>As specified in Table 1 of the specification.</p> <p>No visible damage (torsion not applicable).</p> <p>No visible damage. Legible marking. $\Delta C/C \leq 1\%$ of the value measured in 4.3.1.</p>

performance requirements 2222 455 – 457	performance requirements 2222 460 – 462
<p>Good tinning as evidenced by free flowing of the solder with wetting of the terminations.</p>	<p>Good tinning as evidenced by free flowing of the solder with wetting of the terminations.</p>
<p>As specified in Tables 1 to 3 of the specification.</p>	<p>As specified in Tables 1 to 3 of the specification.</p>
<p>No visible damage.</p>	<p>No visible damage.</p>
<p>No visible damage. Legible marking. $\Delta C/C \leq 1\% + 0,5 \text{ pF}$ for $C_R \leq 1000 \text{ pF}$, $\leq 1\%$ for $C_R > 1000 \text{ pF}$ of the value measured in 4.3.1.</p>	<p>No visible damage. Legible marking. $\Delta C/C \leq 1\% + 0,5 \text{ pF}$ for $C_R \leq 1000 \text{ pF}$, $\leq 1\%$ for $C_R > 1000 \text{ pF}$ of the value measured in 4.3.1.</p>

sub-clause number and test (see Note 1)	D or ND	conditions of test (see Note 1)	performance requirements 2222 357 5
<p>Sub-group C1B Other part of sample of sub-group C1</p>	D		
4.6.1 Initial measurements		Capacitance for $C_R \leq 1000 \text{ pF}$ at 100 kHz, $C_R > 1000 \text{ pF}$ at 1 kHz Tangent of loss angle for $C_R \leq 1000 \text{ pF}$ at 1 MHz, $C_R > 1000 \text{ pF}$ at 100 kHz	
4.6 Rapid change of temperature		θ A = lower cat. temp. θ B = upper cat. temp. 5 cycles, duration $t = 30 \text{ min.}$ Visual examination	No visible damage.
4.7 Vibration		Method of mounting see Note below. Procedure B4. Frequency range: 10 to 55 Hz Pulse shape: half sine Amplitude: 0,75 mm or acceleration: 98 m/s ² (whichever is the less severe) Total duration: 6 h	
4.7.2 Final inspection		Visual examination	No visible damage.
Intermediate measurements		Capacitance	$\Delta C/C \leq 1\%$ of the value measured in 4.6.1.
4.9 Shock		Tangent of loss angle Method of mounting see Note below. Pulse shape: half sine Acceleration: 490 m/s ² Duration of pulse: 11 ms	As in GENERAL DATA of the specification.
4.9.3 Final measurements		Visual examination Capacitance	No visible damage. $\Delta C/C \leq 1\%$ of the value measured in 4.6.1.
		Tangent of loss angle	As in GENERAL DATA of the specification.

Note

The capacitor shall be mechanically fixed by the leads and the body (or stand-off pips of style 2222 357 5) shall be in good contact with the printed-wiring board, also the body of capacitors with a mass > 6 g shall be clamped to the printed-wiring board.

performance requirements
2222 455 – 457

performance requirements
2222 460 – 462

No visible damage.

No visible damage.

No visible damage.
 $\Delta C/C \leq 1\% + 0,5 \text{ pF}$
 for $C_R \leq 1000 \text{ pF}$,
 $\leq 1\%$ for $C_R > 1000 \text{ pF}$
 of the value measured in 4.6.1.
 As in GENERAL DATA of
 the specification.

No visible damage.
 $\Delta C/C \leq 1\% + 0,5 \text{ pF}$
 for $C_R \leq 1000 \text{ pF}$,
 $\leq 1\%$ for $C_R > 1000 \text{ pF}$
 of the value measured in 4.6.1.
 As in GENERAL DATA of
 the specification.

No visible damage.
 $\Delta C/C \leq 1\% + 0,5 \text{ pF}$
 for $C_R \leq 1000 \text{ pF}$,
 $\leq 1\%$ for $C_R > 1000 \text{ pF}$
 of the value measured in 4.6.1.
 As in GENERAL DATA of
 the specification.

No visible damage.
 $\Delta C/C \leq 1\% + 0,5 \text{ pF}$
 for $C_R \leq 1000 \text{ pF}$,
 $\leq 1\%$ for $C_R > 1000 \text{ pF}$
 of the value measured in 4.6.1.
 As in GENERAL DATA of
 the specification.

sub-clause number and test (see Note 1)	D or ND	conditions of test (see Note 1)	performance requirements 2222 357 5
<p>Sub-group C1 Combined sample of specimens of Sub-groups C1A and C1B 4.10 Climatic sequence 4.10.2 Dry heat 4.10.3 Damp heat cyclic, Test Db, first cycle 4.10.4 Cold 4.10.6 Damp heat cyclic, Test Db, remaining cycles 4.10.6.2 Final measurements</p>	<p>D</p>	<p>Temperature: upper category temperature Duration: 16 h Temperature: lower category temperature Duration: 2 h Recovery 1 to 2 h Visual examination Capacitance Tangent of loss angle Insulation resistance</p>	<p>No visible damage. Legible marking. $\Delta C/C \leq 1\%$ of value measured in 4.4.2 or 4.9.3. As in GENERAL DATA of the specification or $\leq 1,4$ x value measured in 4.3.1 or 4.6.1 whichever is greater. $\geq 50\%$ of values in GENERAL DATA of the specification.</p>

performance requirements
2222 455 – 457

performance requirements
2222 460 – 462

No visible damage.
Legible marking.
 $\Delta C/C \leq 0,5\% + 0,5 \text{ pF}$
for $C_R \leq 1000 \text{ pF}$,
 $\leq 0,5\%$ for $C_R > 1000 \text{ pF}$
of the value measured in
4.4.2 or 4.9.3.
As in GENERAL DATA of
the specification or $\leq 1,4 \times$
value measured in 4.3.1 or
4.6.1, whichever is greater.
 $\geq 50\%$ of values in GENERAL
DATA of the specification.

No visible damage.
Legible marking.
 $\Delta C/C \leq 0,5\% + 0,5 \text{ pF}$
for $C_R \leq 1000 \text{ pF}$,
 $\leq 0,5\%$ for $C_R > 1000 \text{ pF}$
of the value measured in
4.4.2 or 4.9.3.
As in GENERAL DATA of
the specification or $\leq 1,4 \times$
value measured in 4.3.1 or
4.6.1, whichever is greater.
 $\geq 50\%$ of values in GENERAL
DATA of the specification.

sub-clause number and test (see Note 1)	D or ND	conditions of test (see Note 1)	performance requirements 2222 357 5
<p>Sub-group C2</p> <p>4.11 Damp heat steady state</p> <p>4.11.1 Initial measurements</p> <p>4.11.3 Final measurements</p>	D	<p>Capacitance for $C_R \leq 1000 \text{ pF}$ at 100 kHz, $C_R > 1000 \text{ pF}$ at 1 kHz Tangent of loss angle for $C_R \leq 1000 \text{ pF}$ at 1 MHz, $C_R > 1000 \text{ pF}$ at 100 kHz Recovery: 1 to 2 h Visual examination</p> <p>Capacitance</p> <p>Tangent of loss angle</p> <p>Insulation resistance</p>	<p>No visible damage. Legible marking. $\Delta C/C \leq 2\%$ of the value measured in 4.11.1.</p> <p>As in GENERAL DATA of the specification or $\leq 1,4 \times$ value measured in 4.11.1, whichever is greater. $\geq 50\%$ of values in GENERAL DATA of the specification.</p>
<p>Sub-group C3</p> <p>4.12 Endurance</p> <p>4.12.1 Initial measurements</p> <p>4.12.5 Final measurements</p>	D	<p>Duration: 1000 h; $1,50 U_R$ (d.c.) at 85 °C, $1,50 U_C$ at 100 °C*</p> <p>Capacitance for $C_R \leq 1000 \text{ pF}$ at 100 kHz, $C_R > 1000 \text{ pF}$ at 1 kHz Tangent of loss angle for $C_R \leq 1000 \text{ pF}$ at 1 MHz, $C_R > 1000 \text{ pF}$ at 100 kHz Visual examination</p> <p>Capacitance</p> <p>Tangent of loss angle</p> <p>Insulation resistance</p>	<p>No visible damage. Legible marking. $\Delta C/C \leq 2\%$ of value measured in 4.12.1.</p> <p>As in GENERAL DATA of the specification or $\leq 1,4 \times$ value measured in 4.12.1, whichever is greater. $\geq 50\%$ of values in GENERAL DATA of the specification.</p>

* For styles 2222 455 to 457.

performance requirements
2222 455 – 457

performance requirements
2222 460 – 462

No visible damage.
Legible marking.
 $\Delta C/C \leq 0,5\% + 0,5 \text{ pF}$
for $C_R \leq 1000 \text{ pF}$,
 $\leq 0,5\%$ for $C_R > 1000 \text{ pF}$
of the value measured in 4.11.1.
As in GENERAL DATA of
the specification or $\leq 1,4 \times$
value measured in 4.11.1,
whichever is greater.
 $\geq 50\%$ of values in GENERAL
DATA of the specification.

No visible damage.
Legible marking.
 $\Delta C/C \leq 1\% + 1 \text{ pF}$
for $C_R \leq 1000 \text{ pF}$,
 $\leq 1\%$ for $C_R > 1000 \text{ pF}$
of the value measured in 4.11.1.
As in GENERAL DATA of
the specification or $\leq 1,4 \times$
value measured in 4.11.1,
whichever is greater.
 $\geq 50\%$ of values in GENERAL
DATA of the specification.

No visible damage.
Legible marking.
 $\Delta C/C \leq 1\% + 0,5 \text{ pF}$
for $C_R \leq 1000 \text{ pF}$,
 $\leq 1\%$ for $C_R > 1000 \text{ pF}$
of the value measured in 4.12.1.
As in GENERAL DATA of
the specification or $\leq 1,4 \times$
value measured in 4.12.1,
whichever is greater.
 $\geq 50\%$ of values in GENERAL
DATA of the specification.

No visible damage.
Legible marking.
 $\Delta C/C \leq 1\% + 0,5 \text{ pF}$
for $C_R \leq 1000 \text{ pF}$,
 $\leq 1\%$ for $C_R > 1000 \text{ pF}$
of the value measured in 4.12.1.
As in GENERAL DATA of
the specification or $\leq 1,4 \times$
value measured in 4.12.1,
whichever is greater.
 $\geq 50\%$ of values in GENERAL
DATA of the specification.

sub-clause number and test (see Note 1)	D or ND	conditions of test (see Note 1)	performance requirements 2222 357 5
Sub-group C4 4.2.5 Variation of capacitance with temperature	D	Static method; capacitors shall be dried. Number of cycles: 1 Capacitance measurements for $C_R \leq 1000 \text{ pF}$ at 100 kHz, $C_R > 1000 \text{ pF}$ at 1 kHz	Not applicable.
4.2.6 Inductance		Insulation resistance	

performance requirements
2222 455 – 457

performance requirements
2222 460 – 462

Temperature coefficient as in
GENERAL DATA of the
specification.

Temperature coefficient as in
GENERAL DATA of the
specification.

Temperature cyclic drift of
capacitance

Temperature cyclic drift of
capacitance

$\Delta C/C \leq 1\% + 0,5 \text{ pF}$

$\Delta C/C \leq 1\% + 0,5 \text{ pF}$

for $C_R \leq 1000 \text{ pF}$

for $C_R \leq 1000 \text{ pF}$

$\leq 1\%$ for $C_R > 1000 \text{ pF}$

$\leq 1\%$ for $C_R > 1000 \text{ pF}$

of the value measured in
4.4.2 or 4.9.3.

of the value measured in
4.4.2 or 4.9.3.

$\geq 10\ 000 \text{ M}\Omega$.

$\geq 10\ 000 \text{ M}\Omega$.

As in GENERAL DATA of
the specification.

As in GENERAL DATA of
the specification.

additional tests	D or ND	conditions of test (see Note 1)	performance requirements 2222 357 5
Sub-group ADD1 A.1 Heat storage	D	Style 2222 357 5 : Duration: 2000 h, Temperature: upper category temperature	
		Styles 2222 455 – 457 and 2222 460 – 462 Duration: 1000 h, Temperature: upper category temperature	
A.1.1 Initial measurements		Capacitance for $C_R \leq 1000 \text{ pF}$ at 100 kHz, $C_R > 1000 \text{ pF}$ at 1 kHz Tangent of loss angle for $C_R \leq 1000 \text{ pF}$ at 1 MHz, $C_R > 1000 \text{ pF}$ at 100 kHz	
A.1.2 Final measurements		Capacitance	$\Delta C/C \leq 2\%$ of the value measured in A.1.1.
		Tangent of loss angle	As in GENERAL DATA of the specification or $\leq 1,4$ x value measured in A.1.1, whichever is greater.
		Insulation resistance	$\geq 50\%$ of values in GENERAL DATA of the specification.

performance requirements
2222 455 – 457

performance requirements
2222 460 – 462

$\Delta C/C \leq 1\% + 0,5 \text{ pF}$
for $C_R \leq 1000 \text{ pF}$,
 $\leq 1\%$ for $C_R > 1000 \text{ pF}$
of the value measured in A.1.1.
As in GENERAL DATA of
the specification or $\leq 1,4 \times$
value measured in A.1.1,
whichever is greater.
As in GENERAL DATA of
the specification.

$\Delta C/C \leq 1\% + 0,5 \text{ pF}$
for $C_R \leq 1000 \text{ pF}$,
 $\leq 1\%$ for $C_R > 1000 \text{ pF}$
of the value measured in A.1.1.
As in GENERAL DATA of
the specification or $\leq 1,4 \times$
value measured in A.1.1,
whichever is greater.
As in GENERAL DATA of
the specification.

additional tests	D or ND	conditions of test (see Note 1)	performance requirements 2222 357 5
<p>Sub-group ADD2 A.2 Solvent resistance, Mil STD-202F, method 215 B</p>		<p>GROUP 1: De-ionized water, followed by mixture of isopropyl alcohol and mineral spirits</p> <p>GROUP 2: 1-1-1-Trichloroethane</p> <p>GROUP 3: Azeotropic mixture of trichlorotrifluoroethane and methylene chloride. Temperature: 25 °C</p>	
<p>A.2.1 Initial measurements</p>		<p>Capacitance for $C_R \leq 1000 \text{ pF}$ at 100 kHz, $C_R > 1000 \text{ pF}$ at 1 kHz Tangent of loss angle for $C_R \leq 1000 \text{ pF}$ at 1 MHz, $C_R > 1000 \text{ pF}$ at 100 kHz</p>	
<p>A.2.2 Final measurements</p>		<p>Capacitance</p> <p>Tangent of loss angle</p> <p>Insulation resistance</p>	<p>$\Delta C/C \leq 1\%$ of value measured in A.2.1.</p> <p>As in GENERAL DATA of the specification or $\leq 1,4 \times$ value measured in A.2.1, whichever is greater. $\geq 50\%$ of values in GENERAL DATA of the specification.</p>

performance requirements
2222 455 – 457

performance requirements
2222 460 – 462

Not applicable.

$\Delta C/C \leq 1\% + 0,5 \text{ pF}$
 for $C_R \leq 1000 \text{ pF}$,
 $\leq 1\%$ for $C_R > 1000 \text{ pF}$
 of the value measured in A.2.1.
 As in GENERAL DATA of
 the specification or $\leq 1,4 \times$
 value measured in A.2.1,
 whichever is greater.
 $\geq 50\%$ of values in GENERAL
 DATA of the specification.

additional tests	D or ND	conditions of test	performance requirements 2222 357 5
<p>Sub-group ADD3 A.3 Detergent resistance</p> <p>A.3.1 Initial measurements</p> <p>A.3.2 Final measurements</p>	D	<p>Density 20g/l dishwater detergent Temperature 70 °C, during 3 min. Followed by rinsing in clear water for 1 min. Recovery time > 2 h.</p> <p>Capacitance for C_R ≤ 1000 pF at 100 kHz, C_R > 1000 pF at 1 kHz Tangent of loss angle for C_R ≤ 1000 pF at 1 MHz, C_R > 1000 pF at 100 kHz</p> <p>Capacitance</p> <p>Tangent of loss angle</p> <p>Insulation resistance</p>	<p>ΔC/C ≤ 1% of value measured in A.3.1.</p> <p>As in GENERAL DATA of the specification or ≤ 1,4 x value measured in A.3.1, whichever is greater. ≥ 50% of values in GENERAL DATA of the specification.</p>
<p>Sub-group ADD4 A.4 Resistance to soldering heat with pre-heating</p> <p>A.4.1 Initial measurements</p> <p>A.4.2 Final measurements</p>	D	<p>Capacitors mounted on a 1,6 mm board with non-plated holes Body temp.: 80 °C Bath temp.: 260 °C Dwell time: 5 s</p> <p>Capacitance for C_R ≤ 1000 pF at 100 kHz, C_R > 1000 pF at 1 kHz</p> <p>Capacitance</p>	<p>ΔC/C ≤ 1% of value measured in A.4.1.</p>
<p>Sub-group ADD5 A.5 Climatic test on taped type</p>		<p>250 h at 40 ± 2 °C R.H. 90 to 95% Recovery time 24 h.</p>	<p>Not applicable.</p>

performance requirements 2222 455 – 457	performance requirements 2222 460 – 462
<p>Not applicable.</p>	<p>$\Delta C/C \leq 1\% + 0,5 \text{ pF}$ for $C_R \leq 1000 \text{ pF}$, $\leq 1\%$ for $C_R > 1000 \text{ pF}$ of the value measured in A.3.1. As in GENERAL DATA of the specification or $\leq 1,4 \times$ value measured in A.3.1, whichever is greater. $\geq 50\%$ of values in GENERAL DATA of the specification.</p>
<p>$\Delta C/C \leq 1\% + 0,5 \text{ pF}$ for $C_R \leq 1000 \text{ pF}$, $\leq 1\%$ for $C_R > 1000 \text{ pF}$ of the value measured in A.4.1.</p>	<p>$\Delta C/C \leq 1\% + 0,5 \text{ pF}$ for $C_R \leq 1000 \text{ pF}$, $\leq 1\%$ for $C_R > 1000 \text{ pF}$ of the value measured in A.4.1.</p>
<p>Deviation of tape on a strip of 250 mm taped products $\leq 2\%$. Pull out and tearing forces $\geq 50\%$ of values in GENERAL DATA of the specification.</p>	<p>Deviation of tape on a strip of 250 mm taped products $\leq 2\%$. Pull out and tearing forces $\geq 50\%$ of values in GENERAL DATA of the specification.</p>

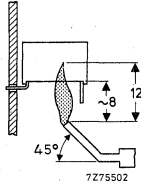
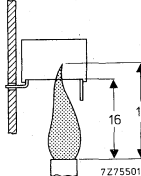
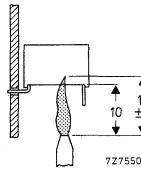
additional tests	D or ND	conditions of tests	performance requirements 2222 357 5
<p>Sub-group ADD6</p> <p>A.6.1 Needle flame test, IEC 695-2-2</p>	D	<p>Bore of gas jet: ϕ 0,5 mm. Fuel: butane Test duration: 20 s One flame application</p>  <p>7275502</p>	<p>After removing the test flame from the capacitor, the capacitor must not continue to burn for more than 15 s, no burning particles must drop from the sample.</p>
<p>A.6.2 Needle flame test, UL 1414</p>		<p>Bore of gas jet: ϕ 10 mm. Fuel: natural gas. Test duration: 3 x 15 s. Time interval between each flame application: 15 s.</p>  <p>7275501</p>	<p>Extinguishing time \leq 15 s after the first and second flame application, \leq 60 s after the third flame application.</p>
<p>A.6.3 Flame test, IEC 65 par. 14.4.1.b (VDE 0860 par. 14.4.1.b)</p>		<p>Bore of gas jet: ϕ 0,5 mm. Fuel: butane. Before testing the capacitors are stored for 2 h at 100 ± 2 °C. Test duration: 1st cycle: 10 s, 2nd cycle: 1 min, 3rd cycle: 2 min. Second and third flame application start directly after extinguishing of the flame on the capacitor.</p>  <p>7275500</p>	<p>Extinguishing time \leq 30 s after each flame application. No burning particles must drop from the sample.</p>

Inspection requirements

KP

performance requirements
2222 455 – 457

performance requirements
2222 460 – 462

Not applicable.

Not applicable.

**A.C. AND PULSE METALLIZED POLYPROPYLENE FILM CAPACITORS
(KP/MKP AND KP/MMKP)**

A.C. AND PULSE METALLIZED POLYPROPYLENE FILM CAPACITORS

KP/MKP radial potted type

- 22,5 and 27,5 mm pitch
- Supplied in boxes

QUICK REFERENCE DATA

Rated capacitance range (E12-series)	0,001 to 0,33 μ F
Tolerance on rated capacitance	$\pm 10\%$, $\pm 5\%$ *
Rated voltage U_R (d.c.)	630 V, 1000 V, 1500 V, 2000 V
Rated voltage U_R (a.c.)	300 V, 400 V, 500 V, 600 V
Climatic category	55/085/56
Rated temperature	85 $^{\circ}$ C
Related specification	IEC 384-16
Performance grade	long life

STYLE



Style 2222 357 6 to 2222 357 9; see Tables 1 to 4.

APPLICATION

These capacitors are for applications where high currents and steep pulses occur. They are mainly used for deflection circuits in television receivers, to operate at high peak currents at line frequency. When requiring advice, please send oscillograms of current and voltage waveforms.

DESCRIPTION

The capacitors consist of a series-constructed, low-inductance wound cell of polypropylene film, aluminium foil and metallized internal electrode. The cell is potted with epoxy resin in a flame retardent polypropylene case. The radial leads are of solder-coated wire. The capacitors can withstand solvents and rinsing liquids without damage. They are provided with small stand-off pips to allow removal of solder flux etc., when cleaning the printed-wiring board.

* $\pm 3,5\%$ to special order.

GENERAL DATA

Dimensions in mm

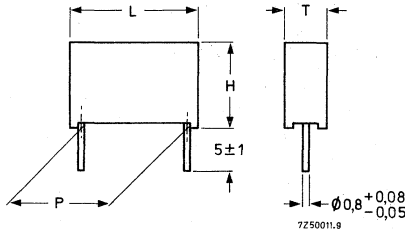

Fig. 1.

Table 1 U_R (d.c.) = 630 V; rated a.c. voltage = 300 V; Fig. 1

rated capacitance* μF	T_{max}	H_{max}	L_{max}	P	mass g	catalogue number 2222 357	
						tol. $\pm 10\%$	tol. $\pm 5\%$
0,047	8,5	18,5	29	$22,5 \pm 0,4$	6	61473	62473
0,056	8,5	18,5			6	61563	62563
0,068	8,5	18,5			6	61683	62683
0,082	10	20			9	61823	62823
0,10	10	20			9	61104	62104
0,12	10	20	34	$27,5 \pm 0,4$	10	61124	62124
0,15	12	22			14	61154	62154
0,18	12	22			14	61184	62184
0,22	15	25			20	61224	62224
0,27	15	25			20	61274	62274
0,33	18	28			28	61334	62334

* Besides the values of the E12 series as quoted, intermediate values of the E24 series (with a tolerance $\pm 5\%$) are available. Other capacitance values and tolerances are available to special order.

Table 2 U_R (d.c.) = 1000 V; rated a.c. voltage = 400 V; Fig. 1

rated capacitance* μF	T_{max}	H_{max}	L_{max}	P	mass g	catalogue number 2222 357	
						tol. $\pm 10\%$	tol. $\pm 5\%$
0,016**	8,5	18,5	29	$22,5 \pm 0,4$	6		72163
0,018**	8,5	18,5			6		72183
0,020**	8,5	18,5			6		72203
0,022**	8,5	18,5			6		72223
0,024**	8,5	18,5			6		72243
0,027**	8,5	18,5			6		72273
0,033	8,5	18,5	29	$22,5 \pm 0,4$	6	71333	72333
0,039	8,5	18,5			6	71393	72393
0,047	10	20			9	71473	72473
0,056	10	20			9	71563	72563
0,068	10	20			10	71683	72683
0,082	12	22	34	$27,5 \pm 0,4$	13	71823	72823
0,10	12	22			13	71104	72104
0,12	15	25			18	71124	72124
0,15	15	25			18	71154	72154
0,18	15	25			18	71184	72184
0,22	18	28			26	71224	72224

* Besides the values of the E12 series as quoted, intermediate values of the E24 series (with a tolerance $\pm 5\%$) are available. Other capacitance values and tolerances are available to special order.

** Especially suited for fly-back purposes.

2222 357 6....
to
2222 357 9....

Table 3 U_R (d.c.) = 1500 V; rated a.c. voltage = 500 V; Fig. 1

rated capacitance* μF	T_{max}	H_{max}	L_{max}	P	mass g	catalogue number 2222 357			
						tol. $\pm 10\%$	tol. $\pm 5\%$		
0,0082**	8,5	18,5	29	$22,5 \pm 0,4$	6		82822		
0,0091**	8,5	18,5			6		82912		
0,010**	8,5	18,5			6		82103		
0,011**	8,5	18,5			6		82113		
0,012**	8,5	18,5			6		82123		
0,013**	8,5	18,5			6		82133		
0,015**	8,5	18,5			6		82153		
0,018	8,5	18,5	29	$22,5 \pm 0,4$	6	81183	82183		
0,022	8,5	18,5			6	81223	82223		
0,024	8,5	18,5			6	81243	82243		
0,027	8,5	18,5			6	81273	82273		
0,033	10	20			9	81333	82333		
0,039	10	20			9	81393	82393		
0,047	10	20			10	81473	82473		
0,056	12	22			34	$27,5 \pm 0,4$	13	81563	82563
0,068	12	22					13	81683	82683
0,082	15	25					18	81823	82823
0,10	15	25	18	81104			82104		
0,12	15	25	18	81124			82124		
0,15	18	28	26	81154	82154				

* Besides the values of the E12 series as quoted, intermediate values of the E24 series (with tolerance $\pm 5\%$) are available. Other capacitance values and tolerances are available to special order.

** Especially suited for fly-back purposes.

Table 4 U_R (d.c.) = 2000 V; rated a.c. voltage = 600 V; Fig. 1. Especially suited for flyback purposes.

rated capacitance μF	T_{max}	H_{max}	L_{max}	P	mass g	catalogue number 2222 357	
						tol. $\pm 10\%$	tol. $\pm 5\%$
0,0010	8,5	18,5			6		92102
0,0011	8,5	18,5			6		92112
0,0012	8,5	18,5			6		92122
0,0013	8,5	18,5			6		92132
0,0015	8,5	18,5			6		92152
0,0016	8,5	18,5			6		92162
0,0018	8,5	18,5			6		92182
0,0020	8,5	18,5			6		92202
0,0022	8,5	18,5			6		92222
0,0024	8,5	18,5			6		92242
0,0027	8,5	18,5			6		92272
0,0030	8,5	18,5			6		92302
0,0033	8,5	18,5	29	$22,5 \pm 0,4$	6		92332
0,0036	8,5	18,5			6		92362
0,0039	8,5	18,5			6		92392
0,0043	8,5	18,5			6		92432
0,0047	8,5	18,5			6		92472
0,0051	8,5	18,5			6		92512
0,0056	8,5	18,5			6		92562
0,0062	8,5	18,5			6		92622
0,0068	8,5	18,5			6		92682
0,0075	8,5	18,5			6		92752
0,0082	10	20			9		92822
0,0091	10	20			9		92912
0,010	10	20			9		92103
0,011	10	20			9		92113
0,012	10	20			9		92123
0,013	10	20			9		92133

2222 357 6....
to
2222 357 9....

Marking

- a. Rated capacitance
- b. Rated voltage
- c. Tolerance on rated capacitance
- d. Category voltage
- e. Year and month of manufacture
- f. Manufacturer's name
- g. Climatic category
- h. Manufacturer's type designation

The capacitors are marked on the top by embossed print with a, b, c, e, f and h as follows:

1st line : rated capacitance in pF or μ F, tolerance and rated d.c. voltage;

2nd line : code for dielectric material, 5th, 6th and 7th digits of the catalogue number, code for factory of origin, production date code according to IEC 62, clause 5.

The manufacturer's identification symbol is indicated at the left.

The capacitors which are especially suited for flyback purposes are also marked with peak-to-peak voltage and repetition frequency (16 kHz).

The package containing the capacitors is marked with a to h.

Mounting

The capacitors are suited for mounting on printed-wiring boards.

Ratings and characteristics

Unless otherwise specified all electrical values apply to an ambient free air temperature of $23 \pm 1 \text{ }^\circ\text{C}$, an atmospheric pressure of 86 to 106 kPa and a relative humidity of $50 \pm 2\%$.

Capacitance

Rated capacitance range at 1 kHz

see Tables 1 to 4

Tolerance on rated capacitance

see Tables 1 to 4

Frequency dependence between 100 Hz and 100 kHz

negligible

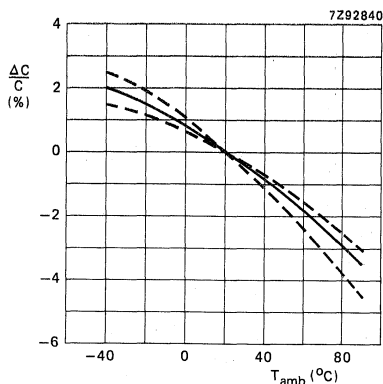

Fig. 2 Capacitance as a function of ambient free air temperature, typical curve.

Voltage

Rated voltage U_R (d.c.)

see Tables 1 to 4

Rated a.c. voltage (r.m.s.), at 50 to 60 Hz

see Tables 1 to 4

Test voltage

between terminations

$1,6 \times U_R$ (d.c.)

between interconnected terminations and case

2840 V (d.c.)

Notes

- The sum of the d.c. voltage and the peak value of the superimposed a.c. voltage must be $\leq U_R$ (d.c.).
- For waveforms other than sinusoidal the maximum permissible dissipation must not be exceeded.

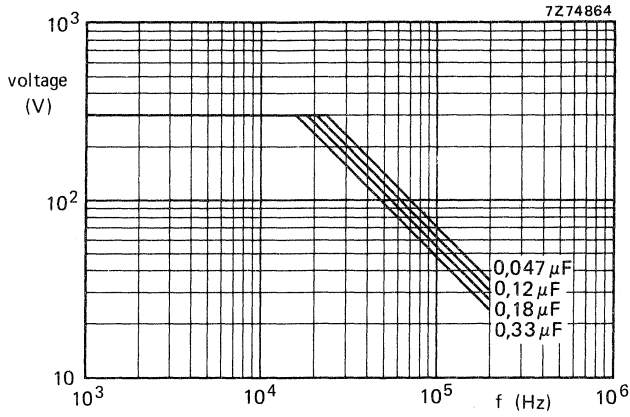

Fig. 3 Rated a.c. voltage (r.m.s. value) as a function of frequency at $T_{amb} \leq 70^\circ\text{C}$, for U_R (d.c.) = 630 V.

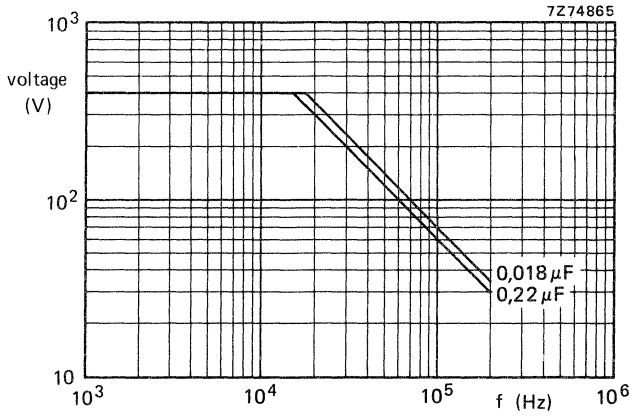

Fig. 4 Rated a.c. voltage (r.m.s. value) as a function of frequency at $T_{amb} \leq 70^\circ\text{C}$, for U_R (d.c.) = 1000 V.

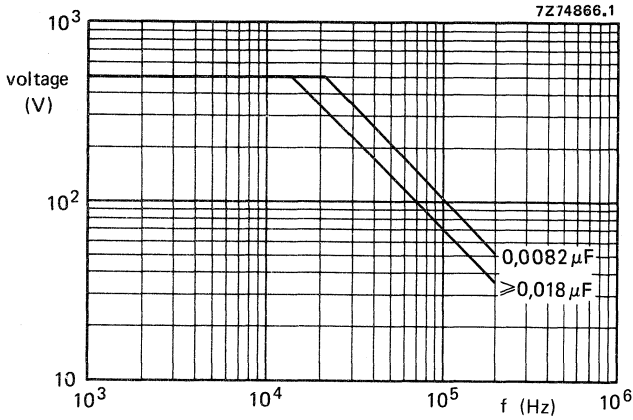

Fig. 5 Rated a.c. voltage (r.m.s. value) as a function of frequency at $T_{amb} \leq 70^\circ C$, for U_R (d.c.) = 1500 V.

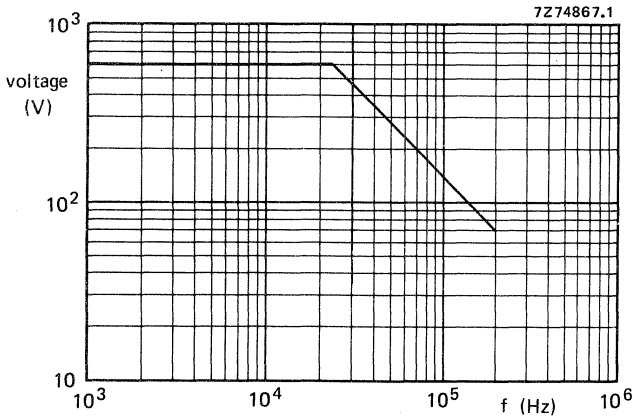

Fig. 6 Rated a.c. voltage (r.m.s. value) as a function of frequency at $T_{amb} \leq 70^\circ C$, for U_R (d.c.) = 2000 V.

2222 357 6...
to
2222 357 9...

Temperature

Climatic category

55/085/56

Rated temperature

85 °C

Storage temperature range

-55 to + 85 °C

Rated voltage pulse slope ($\frac{dU}{dt}$) R

limited by network conditions

Tangent of loss angle at 100 kHz

22,5 mm pitch, 630 V version

$\leq 15 \times 10^{-4}$

1000 V, 1500 V, 2000 V versions

$\leq 10 \times 10^{-4}$

27,5 mm pitch, 630 V version

$\leq 20 \times 10^{-4}$

1000 V version

$\leq 15 \times 10^{-4}$

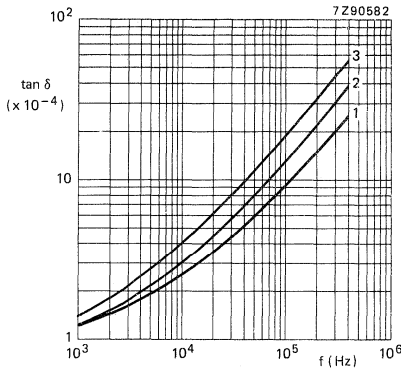

Fig. 7 Maximum $\tan \delta$ as a function of frequency.

Curve 1 = 22,5 mm pitch, 1000 V, 1500 V and 2000 V versions;

curve 2 = 22,5 mm pitch, 630 V version, 27,5 mm pitch, 1000 V version;

curve 3 = 27,5 mm pitch, 630 V version.

Insulation resistance

The insulation resistance is measured after a voltage of 500 ± 50 V has been applied for $1 \text{ min} \pm 5 \text{ s}$, at $T_{\text{amb}} = 23 \text{ °C}$.

R between terminations

$> 100\,000 \text{ M}\Omega$

R between interconnected terminations and case

$> 100\,000 \text{ M}\Omega$

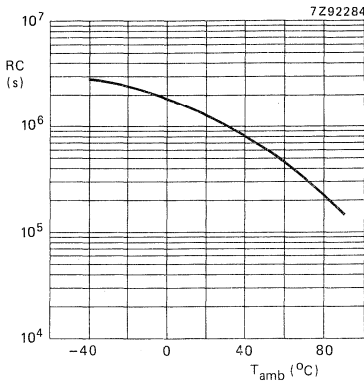

Fig. 8 RC-product as a function of ambient free air temperature; typical curve.

Maximum dissipation

The rated a.c. voltage has been specified for 50 to 60 Hz and at 23 °C. This voltage value must also never be exceeded at other frequencies. This permissible a.c. voltage may further be limited by the following requirements:

1. The power dissipation must not exceed the specified limit P_{max} .
2. The steepness of the a.c. voltage must not exceed the specified limit.

The power dissipated by a capacitor is a function of the voltage across the series resistance (R_s) or of the current through the series resistance and is expressed by

$$P = \frac{V_{R_s}^2}{R_s} = I^2 R_s \tag{1}$$

$$V_{R_s}^2 = \frac{R_s^2}{R_s^2 + 1/\omega^2 C^2} V_{ac}^2$$

Fig. 9.

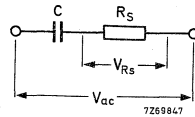

(2a)

As for these capacitors $\tan \delta = R_s \omega C < 0,1$, the formula (2a) can be simplified to

$$V_{R_s}^2 = \frac{R_s^2}{1/\omega^2 C^2} V_{ac}^2 = R_s^2 \omega^2 C^2 V_{ac}^2 \tag{2b}$$

Thus $P = R_s \omega^2 C^2 V_{ac}^2$ (3a)

or $P = \tan \delta \omega C V_{ac}^2$ (3b)

The term $\tan \delta$ can be found from Fig. 7; C (in farads), $\omega = 2\pi f$ and V_{ac} are assumed to be known.

The maximum permissible value of power dissipation (P_{max}), which depends on the dimensions of the capacitor and on the ambient free air temperature, can be found from Fig. 11. Thus, when the actual power has been calculated with equation (3b), Fig. 11 gives the minimum size of capacitor which can dissipate this power.

For a capacitor used with a half sinewave pulse, (Fig. 10), V_{rms} can be expressed by

$$V_{rms}^2 = \frac{1}{2} V_p^2 \frac{T_1}{T_2} \tag{4}$$

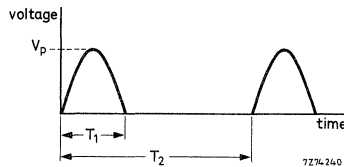
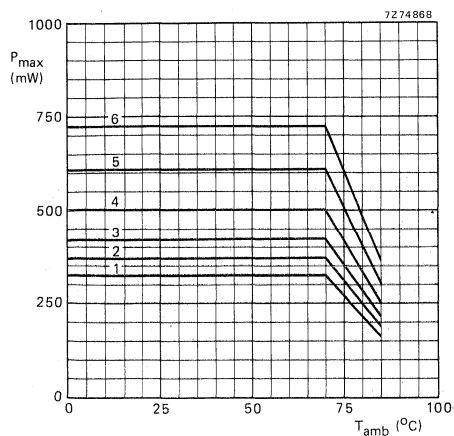

Fig. 10.

Substitution of equation (4) in equation (3b), the maximum power dissipation is

$$P = \frac{1}{2} \cdot \frac{T_1}{T_2} \tan \delta \omega C V_p^2$$

2222 357 6...
to
2222 357 9...



curve	dimensions (mm)		
	T _{max}	H _{max}	L _{max}
1	8,5	18,5	29
2	10	20	29
3	10	20	34
4	12	22	34
5	15	25	34
6	18	28	34

Fig. 11 Maximum dissipation as a function of ambient free air temperature, at various capacitor dimensions.

ORDERING INFORMATION

Order the capacitors by quoting the 12-digit catalogue number as given in Tables 1 to 4.

PACKING

The capacitors are supplied in cardboard boxes; the number per box is shown in the table below.

L _{max} mm	number of capacitors per box
29	200
34	100

A.C. AND PULSE METALLIZED POLYPROPYLENE FILM CAPACITORS

KP/MMKP radial potted type

- 22,5 and 27,5 mm pitch
- Supplied in boxes

QUICK REFERENCE DATA

Rated capacitance range (E12-series)	0,001 to 0,27 μ F
Tolerance on rated capacitance	$\pm 10\%$, $\pm 5\%*$
Rated voltage U_R (d.c.)	630 V, 1000 V, 1500 V, 2000 V
Rated voltage U_R (a.c.)	300 V, 400 V, 450 V, 500 V
Climatic category	55/085/56
Rated temperature	85 $^{\circ}$ C
Related specification	IEC 384-16
Performance grade	long life

STYLE



Style 2222 376; see Tables 1 to 4.

APPLICATION

These capacitors are for applications where high currents and steep pulses occur. They are mainly used for deflection circuits in television receivers, to operate at high peak currents at line frequency. When requiring advice, please send oscillograms of current and voltage waveforms.

DESCRIPTION

The capacitors consist of a low-inductance wound cell of polypropylene film, aluminium foil and double metallized polyethyleneterephthalate (PETP) film. The cell is potted with epoxy resin in a flame retardent polypropylene case. The radial leads are of solder-coated wire.

The capacitors can withstand solvents and rinsing liquids without damage. They are provided with small stand-off pips to allow removal of solder flux etc., when cleaning the printed-wiring board.

* $\pm 3,5\%$ to special order.

GENERAL DATA

Dimensions in mm

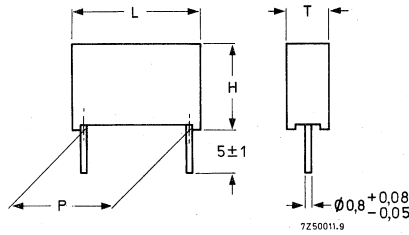

Fig. 1.

Table 1 U_R (d.c.) = 630 V; rated a.c. voltage = 300 V

rated capacitance μF	T_{max}	H_{max}	L_{max}	P	mass g	catalogue number 2222 376	
						tol. $\pm 10\%$	tol. $\pm 5\%$
0,027	6,5	15			2,8	61273	62273
0,033	7,5	16			3,5	61333	62333
0,039	7,5	16	26	$22,5 \pm 0,3$	3,5	61393	62393
0,047	8,5	17,5			4,4	61473	62473
0,056	9,5	18,5			5,1	61563	62563
0,068	11	20			7,4	61683	62683
0,082	11	20			7,4	61823	62823
0,10	11	20			7,4	61104	62104
0,12	13	22,5	31	$27,5 \pm 0,3$	10,2	61124	62124
0,15	13	22,5			10,2	61154	62154
0,18	15	25			12,8	61184	62184
0,22	18	28			18,2	61224	62224
0,27	18	28			18,2	61274	62274

Table 2 U_R (d.c.) = 1000 V; rated a.c. voltage = 400 V

rated capacitance μF	T_{max}	H_{max}	L_{max}	P	mass g	catalogue number 2222 376	
						tol. $\pm 10\%$	tol. $\pm 5\%$
0,015	6,5	15	26	$22,5 \pm 0,3$	2,8	71153	72153
0,018	7,5	16			3,5	71183	72183
0,022	8,5	17,5			4,4	71223	72223
0,027	8,5	17,5			4,4	71273	72273
0,033	8,5	17,5			4,4	71333	72333
0,039	9,5	18,5			5,1	71393	72393
0,047	11	20	31	$27,5 \pm 0,3$	7,4	71473	72473
0,056	11	20			7,4	71563	72563
0,068	11	20			7,4	71683	72683
0,082	13	22,5			10,2	71823	72823
0,10	13	22,5			10,2	71104	72104
0,12	15	25			12,8	71124	72124
0,15	18	28			18,2	71154	72154
0,18	18	28			18,2	71184	72184

Table 3 U_R (d.c.) = 1500 V; rated a.c. voltage = 450 V

rated capacitance μF	T_{max}	H_{max}	L_{max}	P	mass g	catalogue number 2222 376	
						tol. $\pm 10\%$	tol. $\pm 5\%$
0,0068	6,5	15	26	$22,5 \pm 0,3$	2,8	81682	82682
0,0082	6,5	15			2,8	81822	82822
0,010	7,5	16			3,5	81103	82103
0,012	8,5	17,5			4,4	81123	82123
0,015	9,5	18,5			5,1	81153	82153

Table 4 U_R (d.c.) = 2000 V; rated a.c. voltage = 500 V

rated capacitance μF	T_{max}	H_{max}	L_{max}	P	mass g	catalogue number 2222 376	
						tol. $\pm 10\%$	tol. $\pm 5\%$
0,0010	6,5	15			2,8		92102
0,0012	6,5	15			2,8		92122
0,0015	6,5	15			2,8		92152
0,0018	6,5	15			2,8		92182
0,0022	6,5	15			2,8		92222
0,0027	6,5	15			2,8		92272
0,0033	6,5	15	26	$22,5 \pm 0,3$	2,8		92332
0,0039	6,5	15			2,8		92392
0,0047	6,5	15			2,8		92472
0,0056	7,5	16			3,5		92562
0,0068	7,5	16			3,5		92682
0,0082	8,5	17,5			4,4		92822
0,010	9,5	18,5			5,1		92103

Marking

- a. Rated capacitance
- b. Rated voltage
- c. Tolerance on rated capacitance
- d. Category voltage
- e. Year and month of manufacture
- f. Manufacturer's name
- g. Climatic category
- h. Manufacturer's type designation

The capacitors are marked on the top by embossed print with a, b, c, f and h as follows:

1st line : rated capacitance in μF , tolerance and rated d.c. voltage;

2nd line: code for dielectric material, 5th, 6th and 7th digits of the catalogue number, code for factory of origin,
production date code according to IEC 62, clause 5.

The manufacturer's name is indicated at the left.

The capacitors which are especially suited for flyback purposes are also marked with peak-to-peak voltage and repetition frequency (16 kHz).

The package containing the capacitors is marked with a to h.

Mounting

The capacitors are suited for mounting on printed-wiring boards.

Ratings and characteristics

Unless otherwise specified all electrical values apply to an ambient free air temperature of $23 \pm 1^\circ\text{C}$, an atmospheric pressure of 86 to 106 kPa and a relative humidity of $50 \pm 2\%$.

Capacitance

Rated capacitance range at 1 kHz

see Tables 1 to 4

Tolerance on rated capacitance

see Tables 1 to 4

Frequency dependance between 100 Hz and 100 kHz

negligible

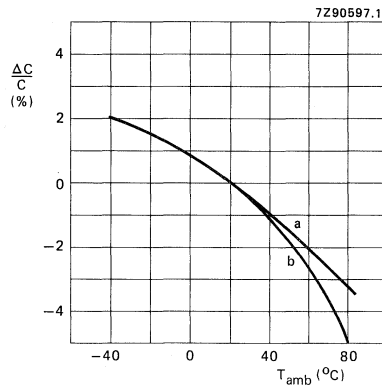

Fig. 2 Capacitance as a function of ambient free air temperature, typical curves.
 a = 1500 V and 2000 V versions;
 b = 630 V and 1000 V versions.

Voltage

Rated voltage U_R (d.c.)

see Tables 1 to 4

Rated a.c. voltage (r.m.s. value), at 50 to 60 Hz

see Tables 1 to 4

Test voltage

between terminations

$1,6 \times U_R$ (d.c.)

between interconnected terminations and case

2700 V (d.c.)

Notes

- The sum of the d.c. voltage and the peak value of the superimposed a.c. voltage must be $\leq U_R$ (d.c.).
- For waveforms other than sinusoidal the maximum permissible dissipation must not be exceeded.

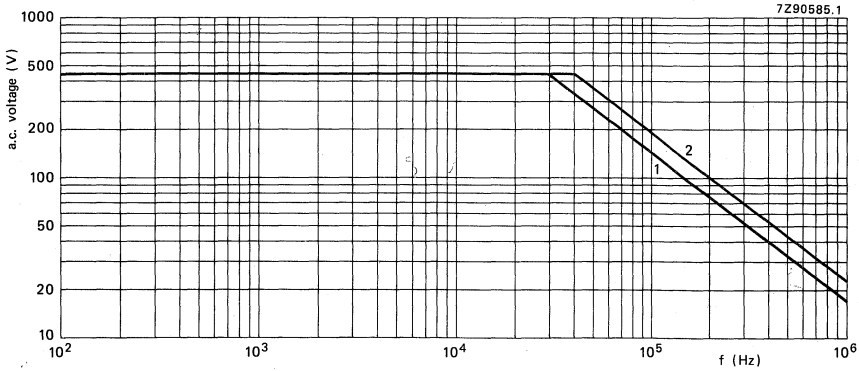

Fig. 5 Rated a.c. voltage (r.m.s. value) as a function of frequency at $T_{amb} \leq 70^{\circ}C$, for U_R (d.c.) = 1500 V.
 Curve 1 = 0,015 μF ;
 curve 2 = 0,0068 μF .

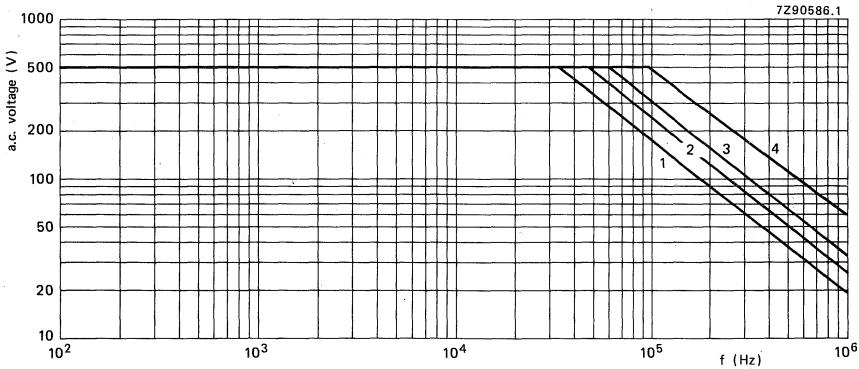

Fig. 6 Rated a.c. voltage (r.m.s. value) as a function of frequency at $T_{amb} \leq 70^{\circ}C$, for U_R (d.c.) = 2000 V.
 Curve 1 = 0,01 μF ;
 curve 2 = 0,0039 μF ;
 curve 3 = 0,0027 μF ;
 curve 4 = 0,001 μF .

Temperature

Climatic category

55/085/56

Rated temperature

85 °C

Storage temperature range

-55 to + 85 °C

Rated voltage pulse slope, $(\frac{dU}{dt}) R$

limited by network conditions

Tangent of loss angle at 100 kHz

22,5 mm pitch, 630 V version

$\leq 15 \times 10^{-4}$

1000 V, 1500 V, 2000 V versions

$\leq 10 \times 10^{-4}$

27,5 mm pitch, 630 V version

$\leq 20 \times 10^{-4}$

1000 V version

$\leq 15 \times 10^{-4}$

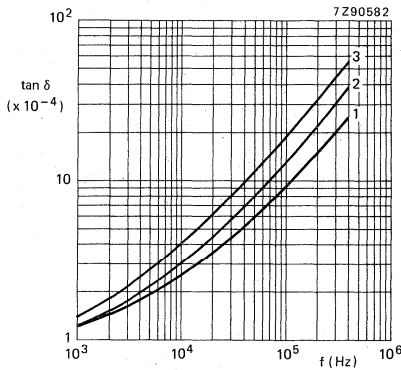

Fig. 7 Maximum tan δ as a function of frequency.

Curve 1 = 22,5 mm pitch, 1000 V, 1500 V and 2000 V versions;

curve 2 = 22,5 mm pitch, 630 V version; 27,5 mm pitch, 1000 V version;

curve 3 = 27,5 mm pitch, 630 V version.

Insulation resistance

The insulation resistance is measured after a voltage of 500 ± 50 V has been applied for $1 \text{ min} \pm 5 \text{ s}$, at $T_{\text{amb}} = 23 \text{ }^\circ\text{C}$.

R between terminations

$> 100\ 000 \text{ M}\Omega$

R between interconnected terminations and case

$> 100\ 000 \text{ M}\Omega$

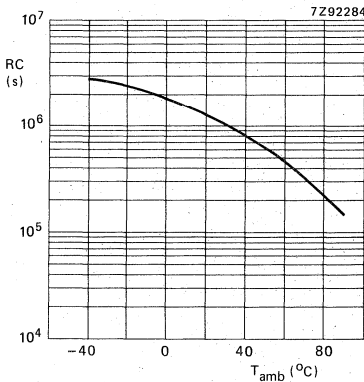

Fig. 8 RC-product as a function of ambient free air temperature; typical curve.

Maximum dissipation

The rated a.c. voltage has been specified for 50 to 60 Hz and at 23 °C. This voltage value must also never be exceeded at other frequencies. This permissible a.c. voltage may further be limited by the following requirements:

1. The power dissipation must not exceed the specified limit P_{max} .
2. The steepness of the a.c. voltage must not exceed the specified limit.

The power dissipated by a capacitor is a function of the voltage across the series resistance (R_s) or of the current through the series resistance and is expressed by

$$P = \frac{V_{R_s}^2}{R_s} = I^2 R_s \tag{1}$$

$$V_{R_s}^2 = \frac{R_s^2}{R_s^2 + 1/\omega^2 C^2} V_{ac}^2 \tag{2a}$$

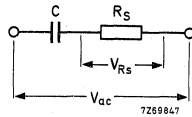

Fig. 9.

As for these capacitors $\tan \delta = R_s \omega C < 0,1$, the formula (2a) can be simplified to

$$V_{R_s}^2 = \frac{R_s^2}{1/\omega^2 C^2} V_{ac}^2 = R_s^2 \omega^2 C^2 V_{ac}^2 \tag{2b}$$

Thus $P = R_s \omega^2 C^2 V_{ac}^2 \tag{3a}$

or $P = \tan \delta \omega C V_{ac}^2 \tag{3b}$

The term $\tan \delta$ can be found from Fig. 7; C (in farads), $\omega = 2\pi f$ and V_{ac} are assumed to be known.

The maximum permissible value of power dissipation (P_{max}), which depends on the dimensions of the capacitor and on the ambient free air temperature, can be found from Fig. 11. Thus, when the actual power has been calculated with equation (3b), Fig. 11 gives the minimum size of capacitor which can dissipate this power.

For a capacitor used with a half sinewave pulse, (Fig. 10), V_{rms} can be expressed by

$$V_{rms}^2 = \frac{1}{2} V_p^2 \frac{T_1}{T_2} \tag{4}$$

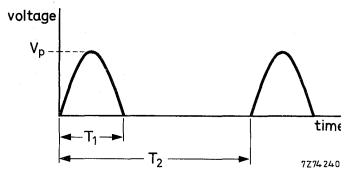
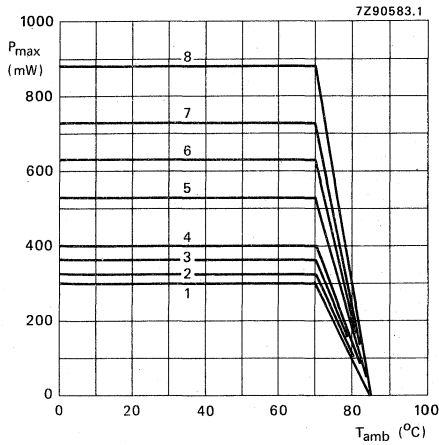

Fig. 10.

Substitution of equation (4) in equation (3b), the maximum power dissipation is

$$P = \frac{1}{2} \cdot \frac{T_1}{T_2} \tan \delta \omega C V_p^2 .$$



curve	dimensions (mm)		
	T _{max}	H _{max}	L _{max}
1	6,5	15	26
2	7,5	16	26
3	8,5	17,5	26
4	9,5	18,5	26
5	11	20	31
6	13	22,5	31
7	15	25	31
8	18	28	31

Fig. 11 Maximum dissipation as a function of ambient free air temperature, at various capacitor dimensions.

ORDERING INFORMATION

Order the capacitors by quoting the 12-digit catalogue number as given in Tables 1 to 4.

PACKING

The capacitors are supplied in cardboard boxes; the number per box is shown in the table below.

L _{max} mm	number of capacitors per box
26	200
31	100

INSPECTION REQUIREMENTS

a.c. and pulse metallized polypropylene film capacitors (KP/MKP and KP/MMKP)

Note 1

Sub-clause numbers of tests and performance requirements refer to the Sectional Specification, IEC-publication 384-16 and GENERAL DATA of the specifications.

Note 2

In this table: D = destructive, ND = non-destructive.

Note 3

For the type ranges with CECC Qualification Approval separate periodic C-tests are carried out as prescribed by the CECC Detail specification.

clause number and test (see Note 1)	D or ND	conditions of test (see Note 1)	performance requirements (see Note 1)
Group A Inspection (lot-by-lot)			
Sub-group A1	ND		
4.1 Visual examination			No mechanical failures. Legible marking and as specified in GENERAL DATA of this specification.
4.2 Dimensions		Gauging	As specified in the Tables of the specifications.
Sub-group A2	ND		
4.2.2 Capacitance		at 1 kHz	Within specified tolerance.
4.2.3 Tangent of loss angle		at 100 kHz	As in GENERAL DATA of the specifications.
4.2.1 Voltage proof (Test A)		at $1,6 \times U_R$ (d.c.) for 1 s	No breakdown or flashover.
4.2.4 Insulation resistance (Test A)		at 500 V	As in GENERAL DATA of the specifications.

sub-clause number and test (see Note 1)	D or ND	conditions of test (see Note 1)	performance requirements
<p>Group B Inspection (periodic)</p> <p>4.5 Solderability</p>	D	<p>Without ageing Method: 1 Non-activated colophony flux Solder bath: 235 °C Dwell time: 2 s</p>	<p>Good tinning as evidenced by free flowing of the solder with wetting of the terminations.</p>
<p>Group C Inspection (periodic)</p> <p>Sub-group C1A Part of sample of Sub-group C1</p> <p>4.1 Dimensions (detail)</p> <p>4.3.1 Initial measurements</p> <p>4.3 Robustness of terminations</p> <p>4.4 Resistance to soldering heat</p> <p>4.4.2 Final measurements</p>	D	<p>Capacitance Tangent of loss angle</p> <p>Tensile and bending Method: 1A Solder bath: 260 °C Duration: 10 s</p> <p>Visual examination</p> <p>Capacitance</p> <p>Tangent of loss angle</p>	<p>As specified in the Tables of the specifications.</p> <p>No visible damage.</p> <p>No visible damage. Legible marking. $\Delta C/C \leq 1\%$ of the value measured initially. increase of $\tan \delta \leq 0,001$. compared to values measured in 4.3.1.</p>

sub-clause number and test (see Note 1)	D or ND	conditions of test (see Note 1)	performance requirements
<p>Sub-group C1B Other part of sample of Sub-group C1</p> <p>4.6.1 Initial measurements</p> <p>4.6 Rapid change of temperature</p> <p>4.7 Vibration</p> <p>4.7.2 Final inspection</p> <p>4.9 Shock</p> <p>4.9.3 Final measurements</p>	<p>D</p>	<p>Capacitance Tangent of loss angle θ A = lower cat. temp. θ B = upper cat. temp. 5 cycles, duration t = 30 min. Visual examination Method of mounting see Note below. Procedure B4. Frequency range: 10 to 55 Hz Amplitude: 0,75 mm or acceleration: 98 m/s² (whichever is the less severe). Total duration: 6 h Visual examination Method of mounting see Note below. Pulse shape: half sine Acceleration: 490 m/s² Duration of pulse: 11 ms Visual examination Capacitance Tangent of loss angle Insulation resistance</p>	<p>No visible damage.</p> <p>No visible damage.</p> <p>No visible damage. $\Delta C/C \leq 2\%$ of the value measured in 4.6.1. Increase of $\tan \delta \leq 0,001$ compared to values measured in 4.6.1. As in GENERAL DATA of the specifications.</p>

Note:

The capacitor shall be mechanically fixed by the leads and the stand-off pips shall be in good contact with the printed-wiring board, also the body of capacitors with a mass > 6 g shall be clamped to the printed-wiring board.

sub-clause number and test (see Note 1)	D or ND	conditions of test (see Note 1)	performance requirements
<p>Sub-group C1 Combined sample of specimens of Sub-groups C1A and C1B 4.10 Climatic sequence 4.10.2 Dry heat 4.10.3 Damp heat cyclic, Test Db, first cycle 4.10.4 Cold 4.10.6 Damp heat cyclic, Test Db, remaining cycles 4.10.6.2 Final measurements</p>	<p>D.</p>	<p>Temperature: upper category temperature Duration: 16 h Temperature: lower category temperature Duration: 2 h Visual examination Capacitance Tangent of loss angle Insulation resistance</p>	<p>No visible damage. Legible marking. $\Delta C/C \leq 1\%$ of value measured in 4.4.2 or 4.9.3. Increase of $\tan \delta \leq 0,002$ compared to values measured in 4.3.1 or 4.6.1. $\geq 50\%$ of values in GENERAL DATA of the specifications.</p>

sub-clause number and test (see Note 1)	D or ND	conditions of test (see Note 1)	performance requirements
<p>Sub-group C2</p> <p>4.11 Damp heat steady state</p> <p>4.11.1 Initial measurements</p> <p>4.11.3 Final measurements</p>	D	<p>Capacitance</p> <p>Tangent of loss angle</p> <p>Visual examination</p> <p>Capacitance</p> <p>Tangent of loss angle</p> <p>Insulation resistance</p>	<p>No visible damage.</p> <p>Legible marking.</p> <p>$\Delta C/C \leq 1\%$ of the value measured in 4.11.1.</p> <p>Increase of $\tan \delta \leq 0,002$ compared to values measured in 4.11.1.</p> <p>$\geq 50\%$ of values in GENERAL DATA of the specifications.</p>
<p>Sub-group C3</p> <p>4.12 Endurance</p> <p>4.12.1 Initial measurements</p> <p>4.12.2 Endurance, d.c.</p> <p>4.12.2.4 Final measurements</p> <p>4.12.3 Endurance, 50 Hz (sub-group C3A)</p> <p>4.12.3.2 Final measurements</p>	D	<p>Capacitance</p> <p>Tangent of loss angle</p> <p>Duration: 2000 h; 1,25 U_R (d.c.) at 85 °C</p> <p>Visual examination</p> <p>Capacitance</p> <p>Tangent of loss angle</p> <p>Insulation resistance</p> <p>Duration: 1000 h, 1,25 x rated a.c. voltage (r.m.s. value), 50 Hz, at 85 °C</p> <p>Capacitance</p> <p>Tangent of loss angle</p> <p>Insulation resistance</p>	<p>No visible damage.</p> <p>Legible marking.</p> <p>Style 2222 357 6 to 2222 357 9 :</p> <p>$\Delta C/C \leq 2\%$ of the value measured in 4.12.1.</p> <p>Style 2222 376:</p> <p>$\Delta C/C \leq 3\%$ of the value measured in 4.12.1.</p> <p>Increase of $\tan \delta \leq 0,002$ compared to values measured in 4.12.1.</p> <p>$\geq 50\%$ of values in GENERAL DATA of the specifications.</p> <p>$\Delta C/C \leq 2\%$ of value measured in 4.12.1.</p> <p>Increase of $\tan \delta \leq 0,004$ compared to values measured in 4.12.1.</p> <p>$\geq 50\%$ of values in GENERAL DATA of the specifications.</p>

additional tests	D or ND	conditions of test	performance requirements
<p>Sub-group ADD1</p> <p>A.1 Heat storage</p> <p>A.1.1 Initial measurements</p> <p>A.1.2 Final measurements</p>	<p>D</p>	<p>Duration: 2000 h Temperature: upper category temperature Capacitance Tangent of loss angle Capacitance Tangent of loss angle Insulation resistance</p>	<p>$\Delta C/C \leq 2\%$ of value measured in A.1.1. Increase of $\tan \delta \leq 0,002$ compared to values measured in A.1.1. As in GENERAL DATA of the specifications.</p>
<p>Sub-group ADD2</p> <p>A.2 Endurance, sinusoidal voltage</p> <p>A.2.2 Final measurements</p>		<p>Duration: 24 h Temperature: 23 °C Voltage: 1,1 x max. a.c. voltage (r.m.s. value), 20 kHz Capacitor body temperature</p>	<p>$\Delta T \leq 10$ °C.</p>

additional tests	D or ND	conditions of test	performance requirements
<p>Sub-group ADD3 A.3 Solvent resistance, Mil STD-202F, method 215 B</p> <p>A.3.1 Initial measurements</p> <p>A.3.2 Final measurements</p>		<p>GROUP 1: De-ionized water, followed by mixture of isopropyl alcohol and mineral spirits</p> <p>GROUP 2: 1-1-1-Trichloroethane</p> <p>GROUP 3: Azeotropic mixture of trichlorotrifluoroethane and methylene chloride Temperature: 25 °C</p> <p>Capacitance Tangent of loss angle</p> <p>Capacitance</p> <p>Tangent of loss angle</p> <p>Insulation resistance</p>	<p>$\Delta C/C \leq 1\%$ of value measured in A.3.1. Increase of $\tan \delta \leq 0,001$ compared to values measured in A.3.1. $\geq 50\%$ of values in GENERAL DATA of the specifications.</p>
<p>Sub-group ADD4 A.4 Detergent resistance</p> <p>A.4.1 Initial measurements</p> <p>A.4.2 Final measurements</p>		<p>Density 20g/l dishwasher detergent Temperature 70 °C, during 3 min. Followed by rinsing in clear water for 1 min. Recovery time > 2 h.</p> <p>Capacitance Tangent of loss angle</p> <p>Capacitance</p> <p>Tangent of loss angle</p> <p>Insulation resistance</p>	<p>$\Delta C/C \leq 1\%$ of value measured in A.4.1. Increase of $\tan \delta \leq 0,001$ compared to values measured in A.4.1. $\geq 50\%$ of values in GENERAL DATA of the specifications.</p>

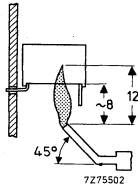
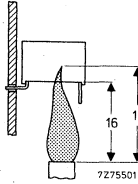
additional tests	D or ND	conditions of tests	performance requirements
<p>Sub-group ADD5</p> <p>A.5 Resistance to soldering heat with pre-heating</p> <p>A.5.1 Initial measurements</p> <p>A.5.2 Final measurements</p>	D	<p>Capacitors mounted on a 1,6 mm board with non-plated holes</p> <p>Body temp.: 80 °C</p> <p>Bath temp.: 260 °C</p> <p>Dwell time: 2 x 5 s with interim free period of 5 s</p> <p>Capacitance</p> <p>Tangent of loss angle</p> <p>Capacitance</p> <p>Tangent of loss angle</p>	<p>$\Delta C/C \leq 1\%$ of value measured in A.5.1.</p> <p>Increase of $\tan \delta \leq 0,001$ compared to values measured in A.5.1.</p>
<p>Sub-group ADD6</p> <p>A.6.1 Needle flame test, IEC 695-2-2</p> <p>A.6.2 Needle flame test, UL 1414</p>	D	<p>Bore of gas jet: ϕ 0,5 mm.</p> <p>Fuel: butane.</p> <p>Test duration: 20s.</p> <p>One flame application</p>  <p>Bore of gas jet: ϕ 10 mm.</p> <p>Fuel: natural gas.</p> <p>Test duration: 3 x 15 s.</p> <p>Time interval between each flame application: 15 s.</p> 	<p>After removing the test flame from the capacitor, the capacitor must not continue to burn for more than 15 s, no burning particles must drop from the sample.</p> <p>Extinguishing time ≤ 15 s after the first and second flame application, ≤ 60 s after the third flame application.</p>

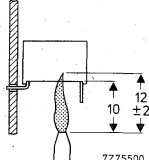
additional tests	D or ND	conditions of test	performance requirements
<p>A.6.3 Flame test, IEC 65 par. 14.4.1.b (VDE 0860 par. 14.4.1.b)</p>		<p>Bore of gas jet: ϕ 0,5 mm. Fuel: butane. Before testing the capacitors are stored for 2h at 100 ± 2 °C. Test duration: 1st cycle: 10s, 2nd cycle: 1 min, 3rd cycle: 2 min. Second and third flame application start directly after extinguishing of the flame on the capacitor.</p> 	<p>Extinguishing time ≤ 30 s after each flame application. No burning particles must drop from the sample.</p>
<p>Sub-group ADD7 A.7 Endurance, 50 Hz A.7.1 Initial measurements A.7.2 Final measurements</p>	D	<p>Duration: 1000 h. Temp.: 23 °C. Voltage: $850 V_{dc} + 550 V_{ac}$ (for 1500 V version), $1000 V_{dc} + 660 V_{ac}$ (for 2000 V version). Capacitance Capacitance Insulation resistance</p>	<p>No interruption. No short circuit.</p>

INTERFERENCE SUPPRESSION CAPACITORS
(MKT-P)

INTERFERENCE SUPPRESSION CAPACITORS

MKT-P radial potted type

- Supplied in boxes

QUICK REFERENCE DATA

Rated capacitance range (E6-series)	0,01 to 1 μ F
Tolerance on rated capacitance	$\pm 20\%$, $\pm 10\%$
Rated voltage U_R (a.c.), 50 to 60 Hz	250 V
Climatic category	40/085/21
Application class according to DIN 40040	GPF
Rated temperature	85 $^{\circ}$ C
Related specification	IEC 384-14
Performance class	X2
Qualified according to	VDE 565-1 and SEMKO

SURVEY OF STYLES

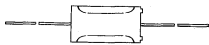

Style 2222 330 0 ,
see Table 1



Style 2222 330 4 ,
see Table 2

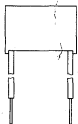

Style 2222 330 8 ,
see Table 3

APPLICATION

For radio interference suppression in:

- small household appliances, e.g. coffee grinders, mixers;
- audio and tv circuits;
- general industrial applications, e.g. test and measuring equipment.

Thanks to the dual dielectric construction any active flammability under fault conditions is prevented.

DESCRIPTION

The capacitors consist of an impregnated low-inductance wound cell of metallized polyethyleneterephthalate (PETP) film and paper film. Three styles are available: with axial leads, with radial leads, and with insulated radial leads.

The cell of the style with axial leads is moulded in yellow flame retardent polypropylene, that of the other styles is potted with epoxy resin in a yellow flame retardent polypropylene case. The leads are solder-coated wire.

The capacitors are provided with stand-off ridges or pips to allow removal of solder flux etc., when cleaning the printed-wiring board.

GENERAL DATA

Style 2222 330 0

Dimensions in mm

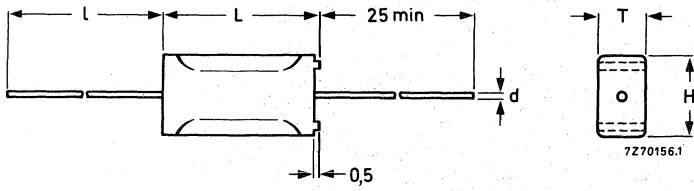

Fig. 1.

Table 1

rated capacitance μF	T_{max}	H_{max}	L_{max}	d	l_{min}	mass	catalogue number 2222 330					
							tol. $\pm 20\%$	tol. $\pm 10\%$				
0,010	6,6	10,4	18,1	0,8	40	1,8	00103	01103				
0,015							00153	01153				
0,022							00223	01223				
0,033							00333	01333				
0,047							00473	01473				
0,068							7,9	11,5	18,1	2,1	00683	01683
0,10							7,8	11,6	23,5	2,7	00104	01104
0,15							9,2	12,9	23,5	3,4	00154	01154
0,22							10,8	14,5	23,5	4,2	00224	01224
0,33	12,5	19,5	31	1,0	50	8,0	00334	01334				
0,47						8,0	00474	01474				

Style 2222 330 4

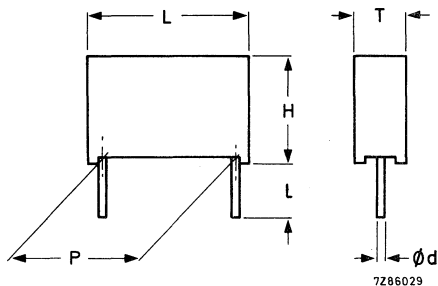

Fig. 2.

Table 2

rated capacitance μF	T_{max}	H_{max}	L_{max}	d	P	mass g	catalogue number 2222 330				
							l = 5 ± 1		l = 25 ± 2		
							tol. ± 20%	tol. ± 10%	tol. ± 20%	tol. ± 10%	
0,010	5	11	17,5	0,8	15 ± 0,4	1,2	40103	41103	44103	45103	
0,015							40153	41153	44153	45153	
0,022							40223	41223	44223	45223	
0,033							40333	41333	44333	45333	
0,047							1,4	40473	41473	44473	45473
0,068							2,0	40683	41683	44683	45683
0,10							2,6	40104	41104	44104	45104
0,15							3,0	40154	41154	44154	45154
0,22							3,7	40224	41224	44224	45224
0,33							5,4	40334	41334	44334	45334
0,47	10,8	40474	41474	44474	45474						
0,68	15	25	31	27,5 ± 0,4	12,9	40684	41684	44684	45684		
1,0						18,2	40105	41105	44105	45105	
				1,0							

Style 2222 330 8

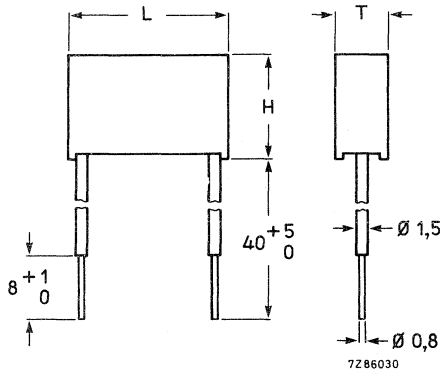

Fig. 3.

Table 3

rated capacitance μF	T_{max}	H_{max}	L_{max}	mass g	catalogue number 2222 330	
					tol. $\pm 20\%$	tol. $\pm 10\%$
0,010	6	12	17,5	1,8	84103	85103
0,015					84153	85153
0,022					84223	85223
0,033					84333	85333
0,047					84473	85473
0,068	7	13	17,5	2,5	84683	85683
0,10	8,5	14,5	17,5	3,0	84104	85104

Marking

- a. Rated capacitance
- b. Rated voltage
- c. Tolerance on rated capacitance
- d. Category voltage
- e. Year and month of manufacture
- f. Manufacturer's name
- g. Climatic category
- h. Manufacturer's type designation
- i. Performance class
- j. Application class
- k. Certification marks

- Style 2222 330 0 :

The marking is impressed on one side with a, b, c, e and i as follows:

1st line: rated capacitance in μF , tolerance ($\pm 10\%$ identified by K, $\pm 20\%$ not identified), rated voltage and performance class;

2nd line: last eight digits of the catalogue number, and production date code.*

On the other side the capacitors are marked with manufacturer's name, application class according to DIN, code for dielectric materials (MKT-P) and approbation symbols.

- Styles 2222 330 4 and 2222 330 8 :

The capacitors are marked on the top by embossed print, with a, b, c, e and i as follows:

1st line: rated capacitance in μF , tolerance ($\pm 10\%$ identified by K or 10, $\pm 20\%$ not identified), rated voltage and performance class;

2nd line: 5th, 6th, 7th, 8th and 9th digits of the catalogue number and code for dielectric materials (MKT-P);

3rd line: climatic category, production date code,* category according to DIN and SEMKO approbation symbol.

Manufacturer's identification symbol and VDE approbation symbol are to the left and to the right respectively of the lines of marking.

The package containing the capacitors is marked with a to k.

Mounting

The capacitors are for printed-wiring applications; capacitors of styles 2222 330 0 and 2222 330 8 are also suited for point to point wiring.

* According to IEC 62, clause 5.

Ratings and characteristics

Unless otherwise specified all electrical values apply to an ambient free air temperature of $23 \pm 1 \text{ }^\circ\text{C}$, an atmospheric pressure of 86 to 106 kPa and a relative humidity of $50 \pm 2\%$.

Capacitance

Rated capacitance range at 1 kHz

see Tables 1 to 3

Tolerance on rated capacitance

see Tables 1 to 3

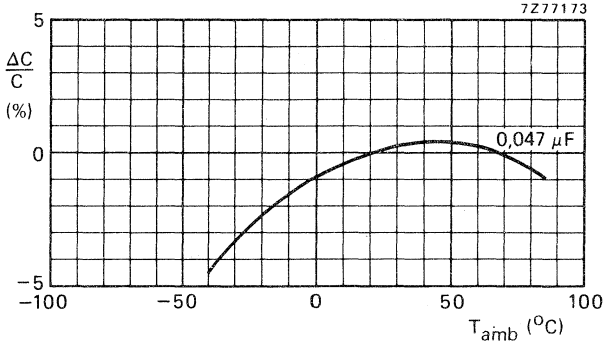

Fig. 4 Capacitance as a function of ambient free air temperature; typical curve.

Voltage

Rated voltage U_R (a.c.) (r.m.s. value), 50 to 60 Hz

250 V

Test voltage

between terminations

1075 V (d.c.)

between interconnected terminations and case (foil method)

2000 V (a.c.)

Temperature

Climatic category

40/085/21

Rated temperature

85 $^\circ\text{C}$

Storage temperature range

-40 to $+85 \text{ }^\circ\text{C}$

Maximum pulse load

100 V/ μs

Resonant frequency

see Fig. 5

Tangent of loss angle

$\tan \delta$ at 1 kHz

$\leq 75 \times 10^{-4}$

$\tan \delta$ at 10 kHz

$\leq 130 \times 10^{-4}$

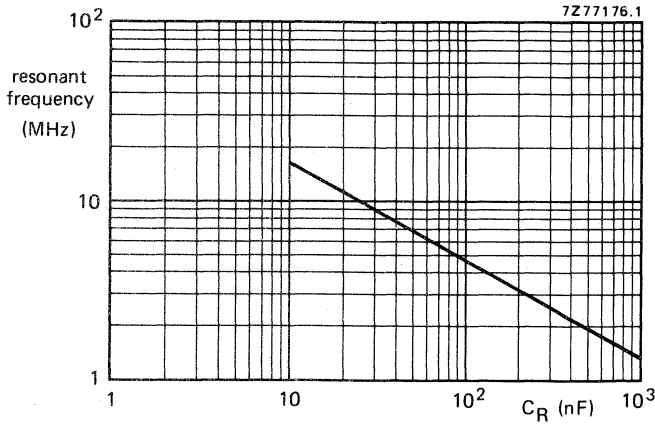

Fig. 5 Resonant frequency as a function of rated capacitance.

Insulation resistance

The insulation resistance is measured after a voltage of 100 ± 15 V has been applied for 1 min \pm 5 s, at $T_{amb} = 20$ °C.

- R between terminations, for $C_R \leq 0,33 \mu F$ > 15 000 M Ω
- RC between terminations, for $C_R > 0,33 \mu F$ > 5000 s
- R between interconnected terminations and case (foil method) > 30 000 M Ω

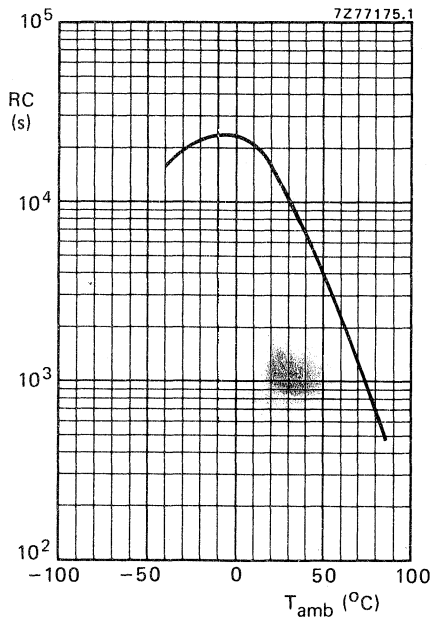

Fig. 6 RC-product as a function of ambient free air temperature; typical curve.

ORDERING INFORMATION

Order the capacitors by quoting the 12-digit catalogue number as shown in Tables 1 to 3.

PACKING**Style 2222 330 0**

The capacitors are packed in boxes of 1000 (for $L_{\max} < 23,5$ mm) and 500 (for $L_{\max} \geq 23,5$ mm).

Style 2222 330 4

The capacitors are packed in boxes; the number per box is given in the table below.

L_{\max} mm	T_{\max} mm	number of capacitors per box	
		$l = 5 \pm 1$	$l = 25 + 2$
17,5	≤ 6	1000	1000
	> 6		500
26		200	100
31		100	125

Style 2222 330 8

The capacitors are packed in boxes of 1000.

INSPECTION REQUIREMENTS

interference suppression capacitors (MKT-P)

Note 1

Sub-clause numbers of tests and performance requirements refer to the Sectional Specification, IEC-publication 384-14 and GENERAL DATA of this specification.

Note 2

In this table: D = destructive, ND = non-destructive.

clause number and test (see Note 1)	D or ND	conditions of test (see Note 1)	performance requirements (see Note 1)
Group A Inspection (lot-by-lot)			
Sub-group A1	ND		
4.1 Visual examination			<ul style="list-style-type: none"> – No mechanical failures. – Legible marking and as specified in GENERAL DATA of this specification.
4.2 Dimensions		Gauging	<ul style="list-style-type: none"> – As specified in Tables 1 to 3 of this specification.
Sub-group A2	ND		
4.2.2 Capacitance		at 1 kHz	<ul style="list-style-type: none"> – Within specified tolerance.
4.2.3 Tangent of loss angle		at 10 kHz	<ul style="list-style-type: none"> – As in GENERAL DATA of this specification.
4.2.1 Voltage proof (Test A)		at 1075 V (d.c.) for 1 s	<ul style="list-style-type: none"> – No breakdown or flashover.
4.2.2 Insulation resistance (Test A)		at 100 V	<ul style="list-style-type: none"> – As in GENERAL DATA of this specification.

sub-clause number and test (see Note 1)	D or ND	conditions of test (see Note 1)	performance requirements
Group B Inspection (periodic) 4.5 Solderability	D	Without ageing Method: 1 Non-activated colophony flux Solder bath: 235 °C Dwell time: 2 s	Good tinning as evidenced by free flowing of the solder with wetting of the terminations.
Group C Inspection (periodic) Sub-group C1A Part of sample of Sub-group C1 4.1 Dimensions (detail) 4.3.1 Initial measurements 4.3 Robustness of terminations 4.4 Resistance to soldering heat 4.4.2 Final measurements	D	Capacitance Tangent of loss angle at 10 kHz Tensile, bending and torsion Method: 1A Solder bath: 260 °C Duration: 10 s Visual examination Capacitance Tangent of loss angle	As specified in Tables 1 to 3 of this specification. No visible damage. No visible damage. Legible marking. $\Delta C/C \leq 2\%$ of the value measured initially. increase of $\tan \delta \leq 0,003$ compared to values measured in 4.3.1.

sub-clause number and test (see Note 1)	D or ND	conditions of test (see Note 1)	performance requirements
Sub-group C1B Other part of sample of Sub-group C1	D		
4.6.1 Initial measurements		Capacitance Tangent of loss angle at 10 kHz	
4.6 Rapid change of temperature		θ A = lower cat. temp. θ B = upper cat. temp. 5 cycles, duration $t = 30$ min. Visual examination	No visible damage.
4.7 Vibration		Method of mounting see Note below. Procedure B4. Frequency range: 10 to 55 Hz Amplitude: 0,75 mm or acceleration: 98 m/s ² (whichever is the less severe) Total duration: 6 h	
4.7.2 Final inspection		Visual examination	No visible damage.
4.9 Shock		Method of mounting see Note below. Pulse shape: half sine Acceleration: 490 m/s ² Duration of pulse: 11 ms	
4.9.3 Final measurements		Visual examination Capacitance Tangent of loss angle Insulation resistance	No visible damage. $\Delta C/C \leq 3\%$ of the value measured in 4.6.1. Increase of $\tan \delta \leq 0,003$ compared to values measured in 4.6.1. As in GENERAL DATA of this specification.

Note:

The capacitor shall be mechanically fixed by the leads and the stand-off pips (ridges) shall be in good contact with the printed-wiring board, also the body of capacitors with a mass > 6 g, and the body of capacitors with insulated leads shall be clamped to the printed-wiring board.

sub-clause number and test (see Note 1)	D or ND	conditions of test (see Note 1)	performance requirements
<p>Sub-group C1</p> <p>Combined sample of specimens of Sub-groups C1A and C1B</p> <p>4.10 Climatic sequence</p> <p>4.10.2 Dry heat</p> <p>4.10.3 Damp heat cyclic, Test Db, first cycle</p> <p>4.10.4 Cold</p> <p>4.10.6 Damp heat cyclic, Test Db, remaining cycles</p> <p>4.10.6.2 Final measurements</p>	D	<p>Temperature: upper category temperature Duration: 16 h</p> <p>Temperature: lower category temperature Duration: 2 h</p>	
		<p>Visual examination</p> <p>Capacitance</p> <p>Tangent of loss angle</p> <p>Insulation resistance</p> <p>Voltage proof 710 V (d.c.), 1 min.</p>	<p>No visible damage. Legible marking. $\Delta C/C \leq 3\%$ of value measured in 4.4.2 or 4.9.3. Increase of $\tan \delta \leq 0,005$ compared to values measured in 4.3.1 or 4.6.1. $\geq 50\%$ of values in GENERAL DATA of this specification. No breakdown or flashover.</p>

sub-clause number and test (see Note 1)	D or ND	conditions of test (see Note 1)	performance requirements
<p>Sub-group C2</p> <p>4.11 Damp heat steady state</p> <p>4.11.1 Initial measurements</p> <p>4.11.3 Final measurements</p>	D	<p>Capacitance Tangent of loss angle at 10 kHz</p> <p>Visual examination</p> <p>Capacitance Tangent of loss angle</p> <p>Insulation resistance</p> <p>Voltage proof 710 V (d.c.) for 1 min.</p>	<p>No visible damage. Legible marking. $\Delta C/C \leq 3\%$ of the value measured in 4.11.1. Increase of $\tan \delta \leq 0,005$ compared to values measured in 4.11.1. $\geq 50\%$ of values in GENERAL DATA of this specification. No breakdown or flashover.</p>
<p>Sub-group C3</p> <p>4.12 Endurance</p> <p>4.12.1 Initial measurements</p> <p>4.12.5 Final measurements</p>	D	<p>Duration: 1000 h 1,25 U_R (a.c.) at 85 °C. Once per hour the voltage is increased to 1000 V (r.m.s.) for 0,1 s, via a resistor of $220 \Omega \pm 10\%$</p> <p>Capacitance Tangent of loss angle at 10 kHz</p> <p>Visual examination</p> <p>Capacitance Tangent of loss angle</p> <p>Insulation resistance</p> <p>Voltage proof 710 V (d.c.) for 1 min.</p>	<p>No visible damage. Legible marking. $\Delta C/C < 10\%$ of value measured in 4.12.1. Increase of $\tan \delta \leq 0,003$ compared to values measured in 4.12.1. $\geq 50\%$ of values in GENERAL DATA of this specification. No breakdown or flashover.</p>

additional tests	D or ND	conditions of test	performance requirements
<p>Sub-group ADD1</p> <p>A.1 Heat storage</p> <p>A.1.1 Initial measurements</p> <p>A.1.2 Final measurements</p>	<p>D</p>	<p>Duration: 1000 h Temperature: upper category temperature</p> <p>Capacitance Tangent of loss angle at 10 kHz</p> <p>Capacitance Tangent of loss angle</p> <p>Insulation resistance</p>	<p>$\Delta C/C \leq 10\%$ of value measured in A.1.1. Increase of $\tan \delta \leq 0,003$ compared to values measured in A.1.1. As in GENERAL DATA of this specification.</p>
<p>Sub-group ADD2</p> <p>A.2 Solvent resistance, Mil STD-202F, method 215 B</p> <p>A.2.1 Initial measurements</p> <p>A.2.2 Final measurements</p>		<p>GROUP 1: De-ionized water, followed by mixture of isopropyl alcohol and mineral spirits</p> <p>GROUP 2: 1-1-1-Trichloroethane</p> <p>GROUP 3: Azeotropic mixture of trichlorotrifluoroethane and methylene chloride Temperature: 25 °C</p> <p>Capacitance Tangent of loss angle at 10 kHz</p> <p>Capacitance Tangent of loss angle at 10 kHz</p> <p>Insulation resistance</p>	<p>$\Delta C/C \leq 2\%$ of value measured in A.2.1. Increase of $\tan \delta \leq 0,003$ compared to values measured in A.2.1. $\geq 50\%$ of values in GENERAL DATA of this specification.</p>

additional tests	D or ND	conditions of test	performance requirements
<p>Sub-group ADD3</p> <p>A.3 Detergent resistance</p> <p>A.3.1 Initial measurements</p> <p>A.3.2 Final measurements</p>		<p>Density 20g/l dishwasher detergent</p> <p>Temperature 70 °C, during 3 min.</p> <p>Followed by rinsing in clear water for 1 min.</p> <p>Recovery time > 2 h.</p> <p>Capacitance</p> <p>Tangent of loss angle at 10 kHz</p> <p>Capacitance</p> <p>Tangent of loss angle</p> <p>Insulation resistance</p>	<p>$\Delta C/C \leq 2\%$ of value measured in A.3.1</p> <p>Increase of $\tan \delta \leq 0,003$ compared to values measured in A.3.1.</p> <p>$\geq 50\%$ of values in GENERAL DATA of this specification.</p>
<p>Sub-group ADD4</p> <p>Not applicable to style 2222 330 8</p> <p>A.4 Resistance to soldering heat with pre-heating</p> <p>A.4.1 Initial measurements</p> <p>A.4.2 Final measurements</p>	D	<p>Capacitors mounted on a 1,6 mm board with non-plated holes</p> <p>Body temp.: 80 °C</p> <p>Bath temp.: 260 °C</p> <p>Dwell time: 2 x 5 s with interim free period of 5 s</p> <p>Capacitance</p> <p>Tangent of loss angle at 10 kHz</p> <p>Capacitance</p> <p>Tangent of loss angle</p>	<p>$\Delta C/C \leq 2\%$ of value measured in A.4.1.</p> <p>Increase of $\tan \delta \leq 0,003$ compared to values measured in A.4.1.</p>

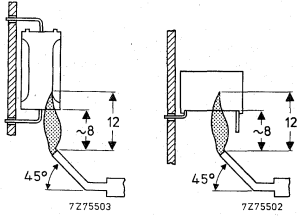
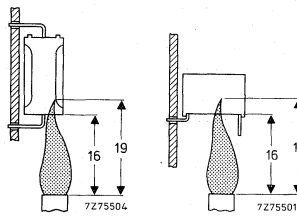
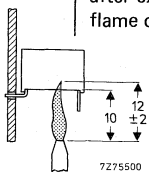
additional tests	D or ND	conditions of tests	performance requirements
<p>Sub-group ADD5</p> <p>A.5.1 Needle flame test, IEC 695-2-2</p>	<p>D</p>	<p>Bore of gas jet: ϕ 0,5 mm. Fuel: butane. Test duration: 20 s. One flame application.</p> 	<p>After removing the test flame from the capacitor, the capacitor must not continue to burn for more than 15 s, no burning particles must drop from the sample.</p>
<p>A.5.2 Needle flame test, UL1414</p>		<p>Bore of gas jet: ϕ 10 mm. Fuel: natural gas. Test duration; 3 x 15 s. Time interval between each flame application: 15 s.</p> 	<p>Extinguishing time \leq 15 s after the first and second flame application, \leq 60 s after the third flame application.</p>
<p>A.5.3 Flame test, IEC 65 par. 14.4.1.b (VDE 0860 par. 14.4.1.b)</p> <p>Not applicable to style 2222 330 0 and capacitors with P = 15 mm</p>		<p>Bore of gas jet: ϕ 0,5 mm. Fuel: butane. Before testing the capacitors are stored for 2h at 100 ± 2 °C. Test duration: 1st cycle: 10 s, 2nd cycle: 1 min, 3rd cycle: 2 min. Second and third flame application start directly after extinguishing of the flame on the capacitor.</p> 	<p>Extinguishing time \leq 30 s after each flame application. No burning particles must drop from the sample.</p>

STANDARD SERIES OF VALUES IN A DECADE

for resistances and capacitances

according to IEC publication 63

E192	E96	E48	E192	E96	E48	E192	E96	E48	E192	E96	E48	E192	E96	E48
100	100	100	169	169	169	287	287	287	487	487	487	825	825	825
101			172			291			493			835		
102	102		174	174		294	294		499	499		845	845	
104			176			298			505			856		
105	105	105	178	178	178	301	301	301	511	511	511	866	866	866
106			180			305			517			876		
107	107		182	182		309	309		523	523		887	887	
109			184			312			530			898		
110	110	110	187	187	187	316	316	316	536	536	536	909	909	909
111			189			320			542			920		
113	113		191	191		324	324		549	549		931	931	
114			193			328			556			942		
115	115	115	196	196	196	332	332	332	562	562	562	953	953	953
117			198			336			569			965		
118	118		200	200		340	340		576	576		976	976	
120			203			344			583			988		
121	121	121	205	205	205	348	348	348	590	590	590			
123			208			352			597					
124	124		210	210		357	357		604	604		E24	E12	E6
126			213			361			612			E3		
127	127	127	215	215	215	365	365	365	619	619	619	10	10	10
129			218			370			626			11		
130	130		221	221		374	374		634	634		12	12	
132			223			379			642			13		
133	133	133	226	226	226	383	383	383	649	649	649	15	15	15
135			229			388			657			16		
137	137		232	232		392	392		665	665		18	18	
138			234			397			673			20		
140	140	140	237	237	237	402	402	402	681	681	681	22	22	22
142			240			407			690			24		
143	143		243	243		412	412		698	698		27	27	
145			246			417			706			30		
147	147	147	249	249	249	422	422	422	715	715	715	33	33	33
149			252			427			723			36		
150	150		255	255		432	432		732	732		39	39	
152			258			437			741			43		
154	154	154	261	261	261	442	442	442	750	750	750	47	47	47
156			264			448			759			51		
158	158		267	267		453	453		768	768		56	56	
160			271			459			777			62		
162	162	162	274	274	274	464	464	464	787	787	787	68	68	68
164			277			470			796			75		
165	165		280	280		475	475		806	806		82	82	
167			284			481			816			91		

Electronic components and materials for professional, industrial and consumer uses from the world-wide Philips Group of Companies

- Argentina:** PHILIPS ARGENTINA S.A., Div. Elcoma, Vedia 3892, 1430 BUENOS AIRES, Tel. 541-7141/7242/7343/7444/7545.
- Australia:** PHILIPS INDUSTRIES HOLDINGS LTD., Elcoma Division, 67 Mars Road, LANE COVE, 2066, N.S.W., Tel. 4270888.
- Austria:** ÖSTERREICHISCHE PHILIPS BAUELEMENTE INDUSTRIE G.m.b.H., Triester Str. 64, A-1101 WIEN, Tel. 629111.
- Belgium:** N.V. PHILIPS & MBLÉ ASSOCIATED, 9 rue du Pavillon, B-1030 BRUXELLES, Tel. (02) 2427400.
- Brazil:** IBRAPE, Caixa Postal 7383, Av. Brigadeiro Faria Lima, 1735 SAO PAULO, SP, Tel. (011) 211-2600.
- Canada:** PHILIPS ELECTRONICS LTD., Electron Devices Div., 601 Milner Ave., SCARBOROUGH, Ontario, M1B 1M8, Tel. 292-5161.
- Chile:** PHILIPS CHILENA S.A., Av. Santa Maria 0760, SANTIAGO, Tel. 39-4001.
- Colombia:** IND. PHILIPS DE COLOMBIA S.A., c/o IPRELENCO LTD., Calle 17, No. 9-21, Of. 202, BOGOTA, D.E., Tel. 57-2347493.
- Denmark:** MINIWATT A/S, Strandlodsvej 2, P.O. Box 1919, DK 2300 COPENHAGEN S, Tel. (01) 541133.
- Finland:** OY PHILIPS AB, Elcoma Division, Kaivokatu 8, SF-00100 HELSINKI 10, Tel. 17271.
- France:** R.T.C. LA RADIOTECHNIQUE-COMPELEC, 130 Avenue Ledru Rollin, F-75540 PARIS 11, Tel. 338 80-00.
- Germany (Fed. Republic):** VALVO, UB Bauelemente der Philips G.m.b.H., Valvo Haus, Burchardstrasse 19, D-2 HAMBURG 1, Tel. (040) 3296-0.
- Greece:** PHILIPS S.A. HELLENIQUE, Elcoma Division, 52, Av. Syngrou, ATHENS, Tel. 9215111.
- Hong Kong:** PHILIPS HONG KONG LTD., Elcoma Div., 15/F Philips Ind. Bldg., 24-28 Kung Yip St., KWAI CHUNG, Tel. (0)-245121.
- India:** PEICO ELECTRONICS & ELECTRICALS LTD., Elcoma Dept., Band Box Building, 254-D Dr. Annie Besant Rd., BOMBAY - 400 025, Tel. 4220387/4220311.
- Indonesia:** P.T. PHILIPS-RALIN ELECTRONICS, Elcoma Div., Panim Bank Building, 2nd Fl., Jl. Jend. Sudirman, P.O. Box 223, JAKARTA, Tel. 716 131.
- Ireland:** PHILIPS ELECTRICAL (IRELAND) LTD., Newstead, Clonskeagh, DUBLIN 14, Tel. 693355.
- Italy:** PHILIPS S.p.A., Sezione Elcoma, Piazza IV Novembre 3, I-20124 MILANO, Tel. 2-6752.1.
- Japan:** NIHON PHILIPS CORP., Shuwa Shinagawa Bldg., 26-33 Takanawa 3-chome, Minato-ku, TOKYO (108), Tel. 448-5611.
(IC Products) SIGNETICS JAPAN LTD., 8-7 Sanbancho Chiyoda-ku, TOKYO 102, Tel. (03) 230-1521.
- Korea (Republic of):** PHILIPS ELECTRONICS (KOREA) LTD., Elcoma Div., Philips House, 260-199 Itaewon-dong, Yongsan-ku, SEOUL, Tel. 794-4202.
- Malaysia:** PHILIPS MALAYSIA SDN. BERHAD, No. 4 Persiaran Barat, Petaling Jaya, P.O.B. 2163, KUALA LUMPUR, Selangor, Tel. 774411.
- Mexico:** ELECTRONICA, S.A. de C.V., Carr. México-Toluca km. 62.5, TOLUCA, Edo. de México 50140, Tel. Toluca 91 (721) 613-00.
- Netherlands:** PHILIPS NEDERLAND, Marktgroep Elconco, Postbus 90050, 5600 PB EINDHOVEN, Tel. (040) 793333.
- New Zealand:** PHILIPS NEW ZEALAND LTD., Elcoma Division, 110 Mt. Eden Road, C.P.O. Box 1041, AUCKLAND, Tel. 605-914.
- Norway:** NORSK A/S PHILIPS, Electronica Dept., Sandstuveien 70, OSLO 6, Tel. 680200.
- Peru:** CADESA, Av. Alfonso Ugarte 1268, LIMA 5, Tel. 326070.
- Philippines:** PHILIPS INDUSTRIAL DEV. INC., 2246 Pasonong Tamo, P.O. Box 911, Makati Comm. Centre, MAKATI-RIZAL 3116, Tel. 86-89-51 to 59.
- Portugal:** PHILIPS PORTUGUESA S.A.R.L., Av. Eng. Duarte Pacheco 6, 1009 LISBOA Codex, Tel. 683121.
- Singapore:** PHILIPS PROJECT DEV. (Singapore) PTE LTD., Elcoma Div., Lorong 1, Toa Payoh, SINGAPORE 1231, Tel. 2538811.
- South Africa:** EDAC (PTY.) LTD., 3rd Floor Rainer House, Upper Railway Rd. & Ove St., New Doornfontein, JOHANNESBURG 2001, Tel. 614-2362/9.
- Spain:** MINIWATT S.A., Balmes 22, BARCELONA 7, Tel. 301 63 12.
- Sweden:** PHILIPS KOMPONENTER A.B., Lidingsvägen 50, S-11584 STOCKHOLM 27, Tel. 08/7821000.
- Switzerland:** PHILIPS A.G., Elcoma Dept., Allmendstrasse 140-142, CH-8027 ZÜRICH, Tel. 01-4882211.
- Taiwan:** PHILIPS TAIWAN LTD., 3rd Fl., San Min Building, 57-1, Chung Shan N. Rd, Section 2, P.O. Box 22978, TAIPEI, Tel. (02)-5631717.
- Thailand:** PHILIPS ELECTRICAL CO. OF THAILAND LTD., 283 Silom Road, P.O. Box 961, BANGKOK, Tel. 233-6330-9.
- Turkey:** TÜRK PHILIPS TICARET A.S., Elcoma Department, İnönü Cad. No. 78-80, İSTANBUL, Tel. 435910.
- United Kingdom:** MULLARD LTD., Mullard House, Torrington Place, LONDON WC1E 7HD, Tel. 01-5806633.
- United States:** (Active Devices & Materials) AMPEREX SALES CORP., Providence Pike, SLATERSVILLE, R.I. 02876, Tel. (401) 762-9000.
(Passive Devices) MEPCO/ELECTRA INC., Columbia Rd., MORRISTOWN, N.J. 07960, Tel. (201) 539-2000.
(Passive Devices & Electromechanical Components) CENTRALAB INC., 5855 N. Glen Park Rd., MILWAUKEE, WI 53201, Tel. (414)228-7380.
(IC Products) SIGNETICS CORPORATION, 811 East Arques Avenue, SUNNYVALE, California 94086, Tel. (408) 739-7700.
- Uruguay:** LUZILECTRON S.A., Avda Uruguay 1287, P.O. Box 907, MONTEVIDEO, Tel. 91 4321.
- Venezuela:** IND. VENEZOLANAS PHILIPS S.A., Elcoma Dept., A. Ppal de los Ruices, Edif. Centro Colgate, CARACAS, Tel. 3605 11

For all other countries apply to: Philips Electronic Components and Materials Division, International Business Relations, Building BAE, P.O. Box 218, 5600 MD EINDHOVEN, The Netherlands, Tel. +31 40723304, Telex 35000 phtnl